



Investing in rural people

Executive Board

142nd Session

Rome, 18–19 September 2024

Thematic evaluation on IFAD's support to gender equality and women's empowerment

Document: EB/2024/142/R.24

Agenda: 6(e)

Date: 6 August 2024

Distribution: Public

Original: English

FOR: REVIEW

Action: The Executive Board is invited to review the thematic evaluation on IFAD's support to gender equality and women's empowerment.

Technical questions:

Indran A. Naidoo

Director

Independent Office of Evaluation of IFAD

e-mail: i.naidoo@ifad.org

Mónica Lomena-Gelis

Senior Evaluation Officer

Independent Office of Evaluation of IFAD

e-mail: m.lomena-gelis@ifad.org

Contents

Acknowledgements	ii
Executive summary	iii
Appendix	
Main report - Thematic evaluation on IFAD's support to gender equality and women's empowerment	1

Acknowledgements

This thematic evaluation was conducted under the strategic guidance of Indran Naidoo, Director of the Independent Office of Evaluation of IFAD (IOE). Fabrizio Felloni, Deputy Director and Suppiramaniam Nanthikesan, Lead Evaluation Officer, IOE, also provided strategic oversight throughout the process. The evaluation was led by Mónica Lomeña-Gelis, Senior Evaluation Officer. Una Murray, Senior Evaluation Consultant, provided technical guidance and important insights throughout the evaluation.

Jeanette Cooke, Evaluation Officer, IOE, provided substantial contributions. Rossella Ciccio and Barbara Befani supported the use of qualitative comparative analysis and Mireia Cano the comparison with eight international organizations. Ratih Dewi and Rati Shublazde provided specialized technical support on the evaluation's portfolio analysis and e-survey, respectively. Consultants Caroline Ochieng, Pou Sovan, Awadia Mohamed, Fatou Mbaye, Tiziana Forte, Ioanna De Barros-Hatcher and Nelson Mango provided valuable support to the country case studies. The desk reviews, data analyses and country case studies were supported by research consultants Alice Formica, Esdras Obossou and Esteban Dupre, and IOE intern Tamoi Fuji. Administrative support was provided by Antonella Sisti, Lucia Bacconi, Nene Etim, Cristina Spagnolo and Daniela Asprella, IOE evaluation assistants. Gresia Bernardini, Norah De Falco, Sarah Pasetto, Shaun Ryan and Alexander Voccia of IOE's evaluation communication unit provided oversight of the communication and editorial aspects of the evaluation.

The report benefited from a peer review conducted within IOE and from the feedback of two independent advisors, Dee Jupp, independent international development consultant and Donna Mertens, Professor Emeritus from Gallaudet University, Washington, D.C.

IOE thanks the IFAD outposted staff in the 11 countries (Argentina, Cambodia, Cameroon, El Salvador, Ethiopia, India, Kenya, Mauritania, Sudan, Tunisia, Türkiye) where case studies were conducted, and the government officials and project management units for their commitment and support during the evaluation. The tireless efforts generously provided throughout the evaluation by the gender and social inclusion team from the Environment, Climate, Gender and Social Inclusion Division were also greatly appreciated. Important data were also provided by the Human Resources Division, the Quality Assurance Group, the Planning, Organizational Development and Budget Division, the Operational Policy and Results Division and the Research and Impact Assessment Division. IOE would like to thank IFAD Management and staff for the input and comments. A special mention goes to the 11 members of the core learning partnership group from various IFAD divisions for their active engagement and input during key moments of the evaluation, such as the self-assessment exercise and the discussion of emerging findings.

Executive summary

A. Context and rationale

1. **Context.** Despite global advancements in gender equality, significant disparities persist, particularly in agriculture and rural development, where women face substantial gaps in access to resources, land and decision-making power. These disparities were exacerbated further during the COVID-19 pandemic, which increased gender inequalities and the domestic burden on women.
2. **Rationale.** In accordance with the 2022 work programme and budget of the Independent Office of Evaluation of IFAD (IOE), approved by the Executive Board at its 134th session in December 2021, IOE conducted a thematic evaluation of IFAD's support to gender equality and women's empowerment (GEWE). Following IOE's previous corporate-level GEWE evaluation in 2010, the Fund approved the IFAD Policy on Gender Equality and Women's Empowerment in 2012 and a gender action plan in 2019. Gender equality is among the five principles of engagement contained in the IFAD Strategic Framework 2016-2025. While keeping a gender-mainstreaming focus in all its activities, IFAD also began mainstreaming gender-transformative approaches into its interventions more systematically. In addition, IFAD carried out decentralization reforms, restructuring and changes in policies and internal processes. Therefore, it was important to assess IFAD's gender performance and whether the Fund is adequately equipped and positioned to fulfil its ambition to promote GEWE in the current global investment environment.
3. **Objectives and scope.** The objectives of the thematic evaluation are twofold: first, to assess IFAD interventions' development effectiveness and contribution to GEWE, and second, to generate actionable lessons and recommendations to guide future policies, strategies and interventions and enhance the impact of IFAD's work on gender equality. Although the evaluation covers the period from 2012 to 2023, it pays special attention to the period from 2016 to 2023, in view of the adoption of the IFAD Strategic Framework 2016-2025. It examines the gender-related outcomes of IFAD's country strategies, project investments, grants and other non-lending activities following the approval of the gender policy in 2012.
4. **Methodological overview.** The thematic evaluation was carried out in line with the Revised IFAD Evaluation Policy and the IFAD Evaluation Manual and sought answers to three overarching questions:
 - How relevant are IFAD gender priorities to the 2030 Agenda; how adaptive are they to changing environments, and how do they align with IFAD's transformational agenda and other contextual changes?
 - What added value has IFAD brought to its various stakeholders when promoting GEWE at the level of individuals, households, communities and formal institutions, policies and legislation?
 - To what extent is IFAD adequately equipped to realize its ambition to promote gender-transformative approaches and to ensure the complementarity of GEWE with other themes?
5. These questions were further developed in an evaluation matrix and were grounded in a conceptual framework and a theory of change, delineating the pathways through which IFAD's inputs and activities are expected to influence GEWE outcomes. These outcomes should contribute to changes in individual agency (empowerment), more equal intra-household power relations, collective agency in informal institutions and policy or formal institutions addressing gender inequality. To deliver on GEWE priorities, the evaluation framework emphasizes

the importance of IFAD's organizational capacity, which hinges on a number of critical factors: adequate human and financial resources dedicated to GEWE, strategic direction in gender priorities, supportive internal operational processes, robust accountability and reporting mechanisms, and a conducive organizational culture that promotes gender and diversity balance.

6. The evaluation used a mix of quantitative and qualitative methods, and triangulated methods and sources. It included a review of the evolution of IFAD's strategic approach to GEWE, a comparison of key dimensions with eight international organizations, a comprehensive analysis of gender information from various corporate reports and a synthesis of recent IOE evaluations. This initial phase helped to identify dimensions requiring primary data collection and deep-dive desk review.
7. The thematic evaluation aggregated evidence from 11 country case studies, namely, Argentina, Cambodia, Cameroon, El Salvador, Ethiopia, India, Kenya, Mauritania, Sudan, Tunisia and Türkiye. The thematic evaluation covered a significant number of country strategic opportunities programmes (COSOPs) and projects approved after the introduction of the gender policy, including some projects approved as gender-transformative. Qualitative comparative analysis was applied to the completed projects to pinpoint the factors influencing the gender rating of IFAD project investments. In-depth examinations of the use of household methodologies in project investments, particularly the Gender Action Learning System (GALS), and of climate and gender provided further insights. This was triangulated with responses from IFAD's operational staff and consultants and from project management units through an e-survey and interviews.
8. **Limitations.** The thematic evaluation identified insufficiencies in reporting on gender analysis processes conducted during IFAD interventions. This was mitigated by additional primary data collection, combining evidence from desk reviews, case studies, the e-survey and interviews. IFAD's systematic introduction of gender-transformative programming is too recent to assess results. The thematic evaluation also analysed the design quality of projects approved by IFAD as gender-transformative and triangulated this information with other sources.

B. Key findings

9. **Overarching question 1:** How relevant are IFAD gender priorities to the 2030 Agenda; how adaptive are they to changing environments, and how do they align with IFAD's transformational agenda and other contextual changes?
10. **The IFAD Policy on Gender Equality and Women's Empowerment and the action plan remain aligned with global strategies for gender equality and are coherent with the Fund's broader priorities.** During the evaluation period, IFAD progressively developed and refined its corporate documents relating to gender, including the gender policy, the action plan on gender mainstreaming and the 2019-2025 gender action plan to mainstream gender-transformative approaches. These frameworks emphasize economic empowerment, decision-making and representation, and equitable workloads and sharing of benefits as the three strategic objectives to increase IFAD's impact on gender equality and strengthen women's empowerment in poor rural areas. In 2019 IFAD also approved a framework for implementing transformational approaches to mainstreaming themes, namely, gender, youth, nutrition and environment and climate.
11. IFAD's strategic objectives are well aligned with Sustainable Development Goal (SDG) 5 on gender equality. However, IFAD's corporate documents fail to cover fully a number of key areas of the SDG 5 targets, including the adoption of legal frameworks for the promotion of gender equality and undertaking reforms to ensure equitable access to ownership and control over land for rural men and

women. The need for structural transformation, proposed in the 2019 gender action plan, by mainstreaming gender-transformative approaches, is in line with the 2030 Agenda and the current IFAD strategic framework. Further, it is borne out by the latest research on gender and food security in developing contexts and the efforts of other comparator organizations.

12. **The existing policy is outdated given the extent of changes to corporate GEWE commitments.** Gender-transformative concepts are now included in IFAD's corporate reporting, despite not being formally defined in the 2012 gender policy. For instance, since 2013 the Report on IFAD's Development Effectiveness (RIDE) tracks as "gender-transformative" the budgets of activities "tackling the underlying social norms, attitudes, behaviours and social systems" in project designs. Moreover, the highest rating for GEWE during implementation and completion was also understood as "gender-transformative". Replenishment commitments on the proportion of projects approved as gender-transformative were added in 2016. The descriptors of gender-transformative projects and the use of the gender marker were also developed following the approval of the 2019 gender action plan. Likewise, corporate documents relating to gender fail to consider fully the ways in which gender intersects with other social identities and axes of power, in line with the IFAD Poverty Targeting Policy 2023 and more recent literature.
13. The progressive development and refinement of corporate documents on gender has not sufficed to guide the consistent operationalization of IFAD's contribution to GEWE. This may partly explain IFAD's mixed performance in contributing to GEWE, as discussed hereafter.
14. **Overarching question 2:** What added value has IFAD brought to its various stakeholders when promoting GEWE at the level of individuals, households, communities and formal institutions, policies and legislation?
15. **IFAD's performance towards achieving the three strategic objectives has been mixed.** The main way in which IFAD COSOPs, projects and grants have contributed to GEWE is by helping **rural men and women** to gain access to key productive assets, which is IFAD's first gender strategic objective. The thematic evaluation identified various good practices and results, including in contexts with high gender inequality. According to an analysis of 23 recent IOE evaluations, the 29 completed projects and the country case studies, while equal access to rural finance, technical training and transitioning to commercial farming are often associated with women's economic empowerment, in some cases their benefits have not been fully assessed.
16. Efforts to ensure an equal voice and representation – the second gender strategic objective – in **communities and rural institutions** have not yielded the expected results. Country case studies have confirmed that women tend to occupy accounting or administrative roles in rural organizations' management committees wherein IFAD promotes equal quotas of men and women. While innovative methodologies, like Cerrando Brecha, tested in IFAD's portfolio in Central America, have shown potential, their impacts have not been captured adequately in project monitoring and evaluation (M&E) systems.
17. Use of the GALS, piloted and tested through IFAD projects and grants, is linked to more equal **intra-household** decision-making and workload sharing, which is the third gender policy objective. GALS, like other household methodologies, has also been used to discuss other issues directly linked to the root causes of gender inequality in rural areas, such as access to land and other natural resources, and more sensitive issues such as gender-based violence. The funding of time- or labour-saving infrastructure and equipment through IFAD operations is also often portrayed as helping to reduce workloads and the drudgery of tasks typically

- performed by rural women and children. However, pathways to map the contribution to GEWE of such infrastructure and equipment have been lacking.
18. IFAD interventions have successfully implemented a number of ways of facilitating rural women's access to land and other natural resources without addressing land tenure **policies at national level**. Limited land tenure and secured access to land and other resources are among the most pervasive barriers to women's – and young men's – participation in and enjoyment of project interventions. The approaches tested in IFAD interventions range from involving rural women in the participatory mapping of **community land, joint (involving both men and women) titling of farmland** to accepting alternative proof of land possession so that rural women can participate in project activities. **Household** methodologies, such as GALS and household mentoring, also involve discussions around land tenure. In addition, a recent grant is exploring how gender-transformative approaches can be used to secure **women's rights** to resources, including land.
 19. **Limited success in scaling up tested approaches and in policy engagement on GEWE**. The influence of IFAD interventions is concentrated at community, household and individual levels. The thematic evaluation only found a few examples of IFAD's efforts to address gender inequality at the level of **formal institutions** and of **policy engagement** to promote the scaling up of approaches towards GEWE. The inclusion of policy engagement on GEWE is among the criteria to be met for a project design to be approved as gender-transformative. However, reviews conducted during the thematic evaluation and by Management in 2022 of reports on approved gender-transformative project designs found very limited reference to or details of policy engagement. COSOPs are better placed to propose gradual actions through policy engagement and other non-lending activities than individual projects. The review of COSOPs during the thematic evaluation did not identify many cases where the GEWE scaling up note of 2015 or the IFAD approach to policy engagement of 2016 were applied and reported on.
 20. **Challenges to articulating GEWE non-lending activities with IFAD country programmes**. The thematic evaluation found a limited application of knowledge gained through grants, supplementary-funded programmes and other partnership work to enrich country programmes and engage in the promotion of gradual changes in policy and legislation to address gender inequality at community, subregional and national levels. A promising example was found in certain African countries, which are independently starting to scale up GALS after several IFAD interventions have piloted the approach and supported national capacities on GALS.
 21. IFAD has engaged with multi-agency groups and partnered with Rome-based agencies in relation to gender to conceptualize, test and disseminate approaches to promote gender-transformative change in the context of food security, nutrition and sustainable agriculture. Additionally, gender grants and supplementary-funded programmes have been useful for piloting innovations and activities not normally implemented in an investment project. Despite these efforts, interviews and country case studies revealed challenges in coordinating them with IFAD country programmes. Similarly, the GEWE-related results of IFAD's interventions at community and national level are not fully leveraged as part of IFAD's overall advocacy efforts in support of GEWE.
 22. The thematic evaluation identified some of the key underlying reasons for the performance gaps summarized above. Such reasons are linked to the allocation of human resources, gender capacities, leadership and the commitment of Senior Management to GEWE.

23. **Overarching question 3:** To what extent is IFAD adequately equipped to realize its ambition to promote gender-transformative approaches and to ensure the complementarity of GEWE with other themes?
24. **There is no widespread understanding among IFAD staff and key implementing partners of changes in IFAD's approaches, guidance and procedures.** Over the last decade, numerous changes in internal structures and processes have been made to match the progressive development of corporate documents relating to gender. These changes took place during a period in which there was a high staff turnover and a thorough reorganization affecting IFAD's operational cycle. Since the approval of the gender policy, IFAD has produced a number of publications in relation to gender, including how-to-do notes and other guidance and training materials. Most of these publications can be found on IFAD's dedicated gender webpage, which is widely used, according to download data. Nonetheless, these online materials are not entirely coherent or available in all the languages of the United Nations. Unlike the comparator organizations, IFAD does not have a comprehensive and field-friendly gender toolkit and guidance. The country visits and interviews found there to be some confusion as to key concepts of the Fund's approaches to the promotion of GEWE.
25. For example, the thematic evaluation found that various internal and external stakeholders are uncertain about IFAD's current requirements on measuring women's empowerment. Efforts to simplify the women's empowerment in agriculture index to assess the impact of completed projects under the Eleventh Replenishment of IFAD's Resources (IFAD11) are muddled with the requirement to measure empowerment in the baseline surveys of projects approved as gender-transformative, following the IFAD core outcome indicators measurement guidelines. Similarly, country case studies and interviews revealed cases of misinterpretation by representatives of country partner governments and some IFAD staff of concepts related to gender-transformative programming. This may have fuelled fears around the acceptance of an IFAD project as gender-transformative, namely, that it might potentially overcomplicate implementation or overpromise given the country context. The thematic evaluation also confirmed that there was an insufficient amount of information on cost implications and examples of how gender-transformative programming has been applied in practical terms in various settings.
26. **The growth in human resources in the gender and social inclusion team since 2016 has not kept pace with its increase in workload and ambitious replenishment commitments.** The fact that gender mainstreaming is everybody's responsibility, not just the role of the gender and social inclusion team and gender focal points, is not often explicit or fully understood by all staff. The approval of the 2019 framework for implementing environment and climate, gender, nutrition and youth in an integrated way increased the responsibility of staff and consultants previously dealing with gender and targeting to also include other social inclusion themes (youth, persons with disabilities, and Indigenous Peoples, when applicable) and nutrition. Interviews during the thematic evaluation warned about the difficulties faced when only one expert from the social inclusion cluster is responsible for providing quality technical inputs to projects on all of these themes, while simultaneously mobilizing supplementary funds and providing technical support to gender-transformative projects that require more time and expertise. Moreover, various vacancies in IFAD's decentralized offices also led to a greater workload for the gender and social inclusion staff located in regional offices, but with global responsibility. The two pivotal staff positions at headquarters were reassigned and decentralized almost simultaneously, overstressing the capacity of the team to deliver the gender action plan and support operations.

27. **Significant staff capacity gaps to support government implementing partners with GEWE effectively.** Half of the IFAD staff and consultants responding to the thematic evaluation e-survey said that the training they had received was not sufficient. Mandatory online training courses on gender and diversity, equity and inclusion raise awareness about gender issues and explain key gender concepts relevant to both IFAD's programmes and workplace. Non-mandatory training on mainstreaming themes has had relatively limited attendance to date by IFAD staff, despite a 2019 assessment that found a significant gap in technical expertise in IFAD's workforce on this matter. Maintaining a roster of consultants providing expertise and who are up to date with the latest changes in IFAD's approach to GEWE has been problematic.
28. **IFAD has failed to provide adequate capacity-building to key implementing partners to ensure the effective promotion of GEWE in operations and to scale up GEWE results.** Providing adequate training and capacity-building to project management units to promote GEWE is paramount, as IFAD's operation model relies heavily on these government partners for implementation. The involvement of national institutions specialized in gender or women's issues was found to boost project gender ratings in certain countries. Some of the gender grants contributed, in a limited way, to increasing the gender capacities of certain implementers. The gender and social inclusion team shares key information through emailing lists, "the gender network", reaching over 2,000 members, including staff, consultants, project staff and external partners. A more versatile community of practice, the Dgroup platform, was less active than expected from 2020 onwards partly due to staff shortages.
29. The main efforts to improve the capacities of implementing partners are channelled towards project management unit staff through regional training and clinics and the participation of IFAD gender experts during the project start-up workshops. However, half of the project management unit respondents to the thematic evaluation e-survey think that they have not received adequate training on GEWE to support operations. So-called learning routes on gender issues and South-South exchanges between Portuguese-speaking countries were found to be a useful means of opening up spaces to discuss challenges and share experiences of GEWE approaches and practices implemented through IFAD interventions. Both learning initiatives are implemented through expert service providers and grants.
30. The variable quality of gender strategies at design stage and limited reporting of GEWE outcomes can be explained partly by the inconsistent inclusion of an IFAD gender expert in field missions throughout the project cycle. Project design and implementation support processes at IFAD were streamlined in 2018, including a reduction in budget and time allocated, while there was also an increase in requirements to comply with mainstreaming themes. The thematic evaluation found that gender information included in COSOPs and project design reports is diluted under compliance with Social, Environmental and Climate Assessment Procedures (SECAP) and also found there to be limited time to focus on GEWE due to over-stretched staff capacities. Similarly, the inconsistent involvement of gender experts during supervision and implementation support missions is a missed opportunity to provide hands-on support to project management units and other implementing partners and to improve monitoring and reporting on GEWE outcomes. The e-survey responses confirmed that insufficient resources are available to hire gender experts for field missions.
31. **Weaknesses in gender outcome monitoring and reporting.** Although IFAD does not formally report on SDG 5, it does contribute to a number of its targets and indicators. Throughout the evaluation period, IFAD's Results Management Framework and replenishment commitments require data on various indicators to be disaggregated by sex and age. The framework and commitments also set targets on the proportion of projects rated above moderately satisfactory as

regards gender at completion and on projects approved as gender-transformative at design stage. The thematic evaluation found that most of the reported data on gender in project completion reports only deals with reached numbers of quotas of women (and men) participants in project activities. There is less evidence on how project activities contributed to close specific gender gaps identified during the design stage. This can be explained partly by the perception that outreach measures are sufficient to assess the GEWE performance of IFAD operations, as most of the project management unit respondents and less than half of IFAD staff and consultants responded through the thematic evaluation e-survey. The thematic evaluation found the quality of the project designs approved as gender-transformative by IFAD itself to be variable.

32. **IFAD's accountability mechanisms for GEWE have not adequately equipped the Fund to make strategic decisions or to manage to achieve development results effectively.** IFAD lacks a high-level committee on gender to ensure implementation of the policy and action plan, unlike other comparator organizations. For example, the Gender Steering and Implementation Committee at the United Nations Development Programme (UNDP), chaired by the Administrator, monitors the implementation of the gender strategy. While IFAD is held accountable for the promotion of GEWE through various reports, there is no clear indication that such reports have been systematically and strategically discussed in any senior management committee in order to address gaps.
33. Reporting on the implementation of the gender policy has been included as a separate annex in the annual RIDE since 2013 and in the Report on IFAD's Mainstreaming Effectiveness since 2023. The policy action areas on the capacity-building of implementing partners and IFAD as a catalyst for advocacy, partnerships and knowledge management have received less attention and been reported less systematically. Reporting on the United Nations System-wide Action Plan on Gender Equality and the Empowerment of Women (UN-SWAP) has helped move the gender agenda forward at IFAD, but has not entailed internal discussions on possible improvements among relevant stakeholders. The fourth action area of the gender policy, gender and diversity balance, is now included in the Human Resources Division's 5 R Action Plan to Improve Gender Parity in IFAD (2017-2021 and 2022-2026). The 2021 IFAD Strategy on Diversity, Equity and Inclusion improved the accountability framework for gender parity and diversity.
34. **The thematic evaluation identified some progress towards gender balance and diversity in the workforce, and other areas that need to be strengthened.** Gender mainstreaming at all levels of the organization and gender parity and diversity in IFAD's workforce are of paramount importance to the Fund's credibility as an advocate for GEWE in its relations with governments and partners. Women have consistently made up just over half of IFAD's workforce. IFAD compares well with 20 other United Nations agencies in relation to the percentage of women in professional categories (from P1 to P5, directors and other senior management), as of December 2023. However, IFAD does not have a plan to achieve gender parity in all categories and levels, nor has it achieved it, as per UN-SWAP requirements.
35. Further efforts are needed to go beyond the headline figures. For instance, women are less represented in staff categories with decision-making responsibilities in decentralized offices and among field-based consultants and are persistently over-represented among General Service staff. Moreover, according to the Global Staff Survey results, between 2016 and 2022, the perception among women of opportunities to advance their careers worsened, more so than among men. Despite a number of measures in recent years to improve work-life balance, many staff, especially women, continue to perceive such measures as inadequate. There have been initiatives to increase awareness and generate internal discussion around diversity, equity and inclusion. Despite changes in recruitment

processes made to facilitate a better gender and diversity balance, the perception among staff of equal treatment, regardless of their differences, worsened between 2018 and 2022.

36. **Leveraging IFAD's role as a catalyst for change.** Given the intricate and context-specific aspects of gender issues in rural settings, IFAD's function should be that of a catalyst for change on GEWE in the countries it serves. As social change unfolds gradually and is often unpredictable, IFAD must test initiatives, demonstrate results and advocate for gender-mainstreaming and gender-transformative approaches as effective strategies for rural transformation, benefiting IFAD's target population as a whole. IFAD interventions achieve concrete outcomes when they support local communities and national governments in long-term planning, incorporating a blend of lending and non-lending support.
37. The following recommendations aim to enhance IFAD's contribution to GEWE, ensuring that its interventions are well-supported, effectively implemented and capable of catalysing transformative changes and sustainable impacts in rural development.

C. Recommendations

38. **Recommendation 1.** Focus the update of the gender policy and the gender action plan on strengthening IFAD's position to promote gender equality and women's empowerment (GEWE) in agricultural and rural development.
- Identify clearly how IFAD can add value by interpreting what a gender-transformative process means in practical terms at community, project and policy level;
 - Include work with partners to develop pathways where IFAD could contribute to catalysing changes owned by national partners and local stakeholders that address the root causes of gender inequality in rural areas;
 - Spell out for IFAD interventions how gender intersects with multiple drivers of poverty and how gender inequality is exacerbated in fragile contexts;
 - Define how IFAD's GEWE results from interventions at national and community level can be used for advocacy, partnerships and knowledge management to reinforce the Fund's visibility as a key global player on GEWE in rural development.
39. **Recommendation 2.** Strengthen the effectiveness of IFAD's interventions on GEWE through consolidated guidance, promoting its shared understanding and buy-in among relevant stakeholders. To do so, develop:
- Pathways, tailored interventions and outcome-level indicators for IFAD activities contributing to GEWE. Guidance could draw on the GEWE practices typology included in the theory of change for this evaluation. Prioritize developing the pathways towards GEWE outcomes through rural finance, land tenure security, and activities contributing to a fairer distribution of workload and shared benefits between rural men and women;
 - Practical and succinct guidance on the application of gender-transformative programming, for all relevant decision makers, implementing partners and IFAD staff. It should include how gender-transformative programming supports broader development goals, key definitions and examples of successful gender-transformative project designs and pathways of change in different settings, the operational implications and additional requirements, with a description of roles and responsibilities, and capacities required. Ensure the note is available in all IFAD languages;

- A stock-take of efforts to measure women’s empowerment, outlining the roles and responsibilities involved and any capacity gaps;
 - Guidance for IFAD staff on how-to-do policy engagement on GEWE during the design and implementation of COSOPs and gender-transformative projects. It should emphasize communication and partnerships with relevant national (and international) partners.
40. **Recommendation 3.** Ensure that the Fund has human resources with the capacities and competencies to address its GEWE priorities and leverage key partners as necessary. To do so:
- Update the 2019 assessment of IFAD’s workforce technical expertise on gender and social inclusion to identify any staffing gaps and clarify respective roles, priorities and responsibilities in the current decentralized structure. Ensure the available human and budgetary resources are commensurate with the ambition of IFAD GEWE goals and the gender-related replenishment commitments;
 - Strengthen the support to project management units and other implementing partners throughout the project cycle with the systematic inclusion of gender experts in IFAD field missions. Ensure community-generated data is consolidated and interpreted and the cost and benefits of specific approaches, such as GALS and Cerrando Brecha are included in IFAD’s reporting;
 - Partner with expert service providers to deliver short training courses and peer-to-peer learning, including learning routes and web-based communities of practices, for IFAD staff and implementing partners. Capacity development efforts should take a practical perspective which emphasizes the mindset shift towards positive behavioural change regarding GEWE, beyond basic training on gender sensitization and key concepts;
 - Provide targeted training on policy engagement on GEWE for country directors and other project staff in the country. This training should include discussions and analyses of successful examples that have leveraged supplementary funds and grants.
41. **Recommendation 4.** Establish high-level metrics to track and report progress towards IFAD’s GEWE goals to ensure accountability and promote learning. This should include:
- Measures to assess the quality of project designs to promote GEWE and a robust monitoring and reporting system to capture actual GEWE results that IFAD interventions aim to catalyse at individual, household, community and policy/legislation levels;
 - Concrete actions to address gaps identified from periodic assessments of strategic issues related to the implementation of all action areas of the new gender policy, the UN-SWAP, the 5 R Action Plan to Improve Gender Parity in IFAD and the IFAD Strategy on Diversity, Equity and Inclusion;
 - Lessons from regular stock takes drawing on GEWE M&E in operations focused on successful project experiences and challenges. Key human resources, such as staff from project management units, should be part of these learning-oriented exercises.

Thematic evaluation on IFAD's support to gender equality and women's empowerment

Contents

Abbreviations and acronyms	3
I. Background and rationale for evaluation.....	4
A. Background	4
B. Definitions and concepts	5
C. Evaluation objectives and scope	7
D. Conceptual framework	8
E. Evaluation methodology and process	11
F. Evaluation limitations	12
II. Promoting GEWE in IFAD and its evolution.....	15
A. IFAD corporate documents with reference to gender	15
B. GEWE in IFAD interventions	16
C. IFAD efforts to deliver GEWE	20
III. Relevance and coherence of IFAD support to GEWE	23
A. Alignment of gender priorities with Agenda 2030 and global policy debates	23
B. Coherence with IFAD priorities and reforms	24
C. Comparison of IFAD's GEWE approach with other international organizations.	25
D. Relevance of promotion of GEWE in IFAD's interventions	26
IV. IFAD's contribution to GEWE performance	33
A. GEWE performance trends of IFAD interventions	33
B. Contribution of IFAD interventions to GEWE performance	35
C. Factors affecting GEWE performance of IFAD interventions	40
D. Assessment of recent efforts towards gender-transformative programming	42
V. Performance of non-lending activities for GEWE results	46
A. Knowledge management and partnerships at the global level	46
B. Performance of non-lending activities to improve gender approaches and results in IFAD interventions.	47
C. Prospects of GEWE sustainability and scaling up	48
VI. Organizational fit-for-purpose to deliver on gender-related commitments.....	51
A. Human resources	51
B. Gender capacity	54
C. Financial resources	57
D. Accountability, monitoring, reporting and incentives	58
E. Internal processes to support operations	60
F. Gender and diversity balance and organizational culture	61
VII. Conclusions and recommendations	67
A. Conclusions	67
B. Recommendations	70

Annexes

I.	Evaluation matrix	72
II.	Additional definitions used in the evaluation.	76
III.	Theory of change of IFAD interventions.....	78
IV.	Additional information on methodology used for TE on GEWE ...	80
V.	Follow-up of the implementation of the 2010 IOE corporate-level evaluation on gender	115
VI.	IFAD GEWE action areas and indicators, replenishment commitments and SDG 5 targets alignment.....	120
VII.	Timeline of IFAD corporate documents with reference to gender during the evaluation period	123
VIII.	Characteristics of other household methodologies used in IFAD interventions.	124
IX.	Compliance criteria for GT-validated project designs.....	126
X.	Timeline of IFAD’s efforts to improve the measurement of (women’s) empowerment.....	128
XI.	Roles and responsibilities of human resources working on GEWE	133
XII.	Additional info on comparison with other organizations	134
XIII.	GEWE performance ratings and trends in IFAD interventions ..	136
XIV.	Analysis of GEWE M&E weakness and contributing factors	139
XV.	Additional information about the GEWE practices in IFAD investments contributing to gender	141
XVI.	Factors affecting GEWE performance of IFAD interventions.....	149
XVII.	Additional information about the performance of IFAD’s non-lending activities for GEWE results	154
XVIII.	Organizational context and human resources dedicated to gender since 2012.....	158
XIX.	GEWE capacity needs conducted by IFAD	162
XX.	Key gender guidance and tools produced by IFAD during the evaluation period	163
XXI.	Financial resources tracking systems and allocation targets	167
XXII.	Additional information about self-high-level reporting.	170
XXIII.	Gender and diversity balance and organizational culture	173
XXIV.	Bibliography consulted	180
XXV.	List of interviewees.....	192
XXVI.	Senior independent advisers’ report.....	202

Abbreviations and acronyms

APR	Asia and the Pacific Region
ARIE	Annual Report on the Independent Evaluation of IFAD
ARRI	Annual Report on Results and Impact of IFAD Operations
CGIAR	Consultative Group for International Agricultural Research
CLE	Corporate-Level Evaluation
COSOP	Country Strategic Opportunities Programme
CSPE	Country Strategy and Programme Evaluation
DEI	Diversity, Equity and Inclusion
ECOSOC	United Nations Economic and Social Council
ECG	Environment, Climate, Gender and Social Inclusion Division (IFAD)
ESA	Eastern and Southern Africa Region
ESN	Evaluation Synthesis Note
GALS	Gender Action Learning System
GAP	Gender Action Plan
GBV	Gender Based Violence
GEWE	Gender Equality and Women's Empowerment
GFP	Gender Focal Point
GT	Gender Transformative
GTM	Gender Transformative Mechanism
GTAs	Gender Transformative Approaches
HHM	Household Methodologies
HRD	Human Resources Division (IFAD)
IFAD	International Fund for Agricultural Development
IFPRI	International Food Policy Research Institute
IOE	Independent Office of Evaluation (IFAD)
JP	Joint Programmes
KM	Knowledge management
LAC	Latin America and Caribbean Region
M&E	Monitoring and Evaluation
NEN	Near East, North Africa and Europe Region
NGO	Non-Governmental Organization
NLA	Non-lending activities
OPR	Operational Policy and Results Division (IFAD)
PMD	Programme Management Department (IFAD)
PMU	Project Management Unit
PCR	Project Completion Report
PDR	Project Design Report
PDT	Project delivery team
QAG	Quality Assurance Group (IFAD)
QCA	Qualitative Comparative Analysis
RBA	Rome-based Agencies
RIDE	Report on IFAD's Development Effectiveness
RIA	Research and Impact Assessment Division (IFAD)
RWEE	Rural Women's Economic Empowerment
SDG	Sustainable Development Goal
SECAP	Social Environmental and Climate Assessment at IFAD
SKD	Strategy and Knowledge Department (IFAD)
TE	Thematic Evaluation
ToC	Theory of Change
UNSWAP	UN System-Wide Action Plan on Gender Equality and the Empowerment of Women
WCA	West and Central Africa Division
WEAI	Women's Empowerment in Agriculture Index

I. Background and rationale for evaluation

1. This section presents the status of gender inequality in agriculture and rural development in the countries that IFAD serves. It also includes key information about the evaluation: the rationale, objectives, and scope; conceptual framework; definitions used; the methodology; and the constraints faced.

A. Background

2. As approved by the Executive Board at its 134th session in December 2021, the IFAD Independent Office of Evaluation (IOE) conducted a thematic evaluation (TE) to assess the development effectiveness, results, and performance of IFAD-funded interventions in relation to their contribution to Gender Equality and Women's Empowerment (GEWE) during the period 2012-2023.
3. In the past decades, global progress has been made on **Gender Equality and Women's Empowerment (GEWE)**,¹ but advancement towards Sustainable Development Goal 5 has been too slow. The 2023 SDG report stated that only 15.4 per cent of Goal 5 indicators with data are "on track" to reach the 2030 targets². There is a need to catalyse actions to address gender equality issues, not only as defined by SDG 5 targets but also because actions for gender equality affect the outcomes of other SDGs³.
4. **The gains in gender equality in agriculture and agrifood systems are still limited in many aspects.** Although women today have better access to some resources, such as rural finance and digital technologies, the gender gaps in access to land, inputs and services remain significant. Many women continue to be disadvantaged by insecure property rights and limited access to land.⁴ Men have greater ownership or secure tenure rights of agricultural land than women in 40 out of 46 countries (FAO, 2023). Rural women tend to be more excluded in formal and informal land governance systems.⁵ A gender gap in access to land, inputs and services as well as in decision-making power leads to women's lower agricultural labour productivity (UN Women 2019). The gender gap in land productivity of farmers of equal size is 24 percent⁶ and women earn on average just over four fifths of what men earn from on-farm and off-farm wage employment (FAO 2023).
5. **Rural girls and women often bear the brunt of domestic chores and caring for family members.** From childhood, rural girls are often assigned more household chores than boys.⁷ Later in life, women do three times as much unpaid care and domestic work than men, which increases when women are from rural areas, poor families, and married and with small children (UN Women, 2020). In addition, collecting water and gathering firewood are becoming more onerous in some areas because of climate change and depleted forest resources.
6. **The gap in global food insecurity between men and women has decreased, but the cost of maintaining a healthy diet has increased.** In 2022, 33.3 percent of adults in rural regions experienced moderate or severe food insecurity. The difference in the prevalence of moderate or severe food insecurity between men and women decreased from 3.8 percentage points in 2021 to 2.4 percentage

¹ World Bank, 2019; UN Women, 2021; United Nations Children's Fund, 2020.

² For instance, technology for women's empowerment is "on track", while 61.5 per cent of indicators are at a moderate distance (e.g. early marriage, unpaid care and domestic work, women in leaderships) and 23 per cent are "off track" or lack data (violence against women and girls, reproductive health access & rights and equal economic rights).

³ UN SDG Report, Special Edition available [here](#): – see also [progress chart here](#)

⁴ Access to land and other resources confers access to other rights such as use of natural resources, water and trees. Stronger land rights for women are positively associated with greater adoption of technologies, increase in investments and higher levels of agricultural productivity and income, as well as lower rates of domestic violence.

⁵ IFAD 2020. Grant for the Stepping up IFAD's gender transformative agenda – Women's land rights initiative.

⁶ In sub-Saharan Africa, gender gaps in agricultural productivity range from 11 per cent in Ethiopia to 28 per cent in Malawi. <https://www.unwomen.org/sites/default/files/Headquarters/Attachments/Sections/Library/Publications/2019/UN-Women-Policy-brief-11-The-gender-gap-in-agricultural-productivity-in-sub-Saharan-Africa-en.pdf>

⁷ Girls aged 10-14 years old are more likely than boys the same age to spend 21 or more hours on household chores per week <https://data.unicef.org/resources/a-new-era-for-girls-taking-stock-of-25-years-of-progress/>

points in 2022, with the gap for severe food insecurity narrowing from 2.4 to 1.1 percentage points.⁸ However, the cost of maintaining a healthy diet increased globally by 4.3 percent compared to 2020 due to inflation driven in part by the lingering impact of the COVID-19 pandemic (FAO 2023). Many international organizations conducted studies to understand the gender-specific effects of the COVID-19 pandemic. Most of them noted how the pandemic exacerbated gender inequalities and increased domestic labour for women.⁹

7. **Extra efforts are required in rural areas to address underlying gender inequalities identified by women themselves, and to foster equal opportunities.** Without addressing inequalities, 378 million women and girls will be living in extreme poverty in 2025 (compared to 363 million men and boys).¹⁰ The 2011 [FAO in its State of Food Agriculture report](#) calculated that with equal access to productive resources, yields could increase by 20-30 percent; total agricultural output by 2.5 to 4 percent; and 100-150 million people would be out of hunger. FAO (2023) found that development interventions directly empowering women could raise the incomes of an additional 58 million people and increase the resilience of an additional 235 million people.¹¹

B. Definitions and concepts

8. This section provides clarification on important terms used in this TE, based on our literature review, IFAD corporate documents with reference to gender and IFAD's glossary of gender terms (See Annex II for more definitions). **Gender** refers to the socially based expectations of the roles and behaviours of men and women, which are learned and vary over time and within and between locations¹². **Gender equality** implies that women and men have equal rights, freedoms, conditions, and opportunities to access and control resources and enjoy the same status within a society. **Women's empowerment** refers to the expansion of women's ability to make strategic life choices in a context where this ability was previously denied to them (Kaber, 2001). Supporting women's empowerment requires facilitating processes whereby women can reflect on their situation, articulate their priorities and subsequently play an active role in promoting their interests (UN Women, 2015). Supporting women's education and literacy can help empower women to take leadership roles and assert their legal and reproductive rights. Providing economic opportunities can help women achieve financial independence and consequently improve their decision-making power. In addition, challenging gender stereotypes and promoting positive role models can help create a more supportive environment for women's empowerment.
9. **Gender mainstreaming was endorsed by United Nations Member States as the global strategy for gender equality** following the Fourth World Conference on Women in 1995 (see Box 1). Implementation of gender equality strategies is called for in all areas of development (UN Women, 2022).

⁸ The State of Food Security and Nutrition in the World 2023

⁹ UNDP, 2020; FAO and WFP, 2022; World Bank, 2022, among others.

¹⁰ UN Women, 2022, <https://data.unwomen.org/features/poverty-deepens-women-and-girls-according-latest-projections>

¹¹ This publication asserts that projects specifically empowering women yield greater benefits compared to those merely incorporating gender mainstreaming. While over half of bilateral finance for rural development integrates gender, only 6 percent considers gender as fundamental. FAO (2023) The Status of Women in AgriFood Systems.

¹² For evaluative purposes, the TE adopts the concept of gender as a male/female binary used in (i) IFAD corporate documents including the 2012 Policy on GEWE and (ii) the United Nations Agenda 2030 and Sustainable Development Goals. Findings related to gender identity and gender expression are in section VI under diversity.

Box 1**United Nations Economic and Social Council (ECOSOC) definition of gender mainstreaming (1997)**

The process of assessing the implications for women and men of any planned action, including legislation, policies or programmes, in all areas and at all levels. It is a strategy for making women's as well as men's concerns and experiences an integral dimension of the design, implementation, monitoring and evaluation (M&E) of policies and programmes in all political, economic and societal spheres so that women and men benefit equally and inequality is not perpetuated. The ultimate goal is to achieve gender equality.

Source: ECOSOC Agreed Conclusions, 1997.

10. The capacity for gender mainstreaming to produce transformations in unequal gender relations has been questioned by some practitioners and academics. Despite its inclusion in the agenda of governments and multilateral organizations, the process of gender mainstreaming is quite broad and covers a range of interpretations.¹³ Some claim that gender mainstreaming is not transformative or that insufficient resources are allocated for gender mainstreaming within institutions; others argue that deep-rooted cultural and social norms pose barriers to mainstreaming efforts including in development institutions, agencies and governments. Mandates on gender equality derive from the UN Charter and unequivocally reaffirmed the equal rights of men and women. The Convention on the Elimination of all Forms of Discrimination Against Women (CEDAW) has been ratified by 189 states and is often described as a *Bill of Rights for women*.
11. The IFAD 2019 Gender Action Plan (GAP) defines **gender transformative approaches (GTAs)** as programmes and interventions that create opportunities to actively challenge the root causes of inequalities between women and men and promote positions of social and political influence for women. In 2020 joint efforts by the Rome-based agencies have expanded this definition (see Box 2).

Box 2**Characteristics of Gender Transformative Approaches in the context of rural development**

- GTAs seek to remove structural barriers to gender equality and challenge the **distribution of resources and allocation of roles and responsibilities** between men and women;
- help understand, reflect on, challenge and change rigid gender norms and roles, unequal **power dynamics** and discriminatory **social structures**;
- aim to foster more equitable **gender relations within households, communities and organizations** and improve the **position of women in society**;
- facilitate **dialogue, trust and behavioural change** at multiple levels (individual, household, community, systems/institutions);
- use **participatory and experiential learning methodologies**;
- recognize that women often experience **multiple and intersecting forms of discrimination**; and
- explicitly **engage with men** and boys as allies for change and advocates for gender equality.

Source: FAO, IFAD, WFP, 2020. Joint Programme on GTA for food security, nutrition and sustainable agriculture.

12. **GTAs have gained traction in the context of food security and agriculture.**¹⁴ GTAs call for addressing the root causes generating and reproducing economic, social, political, and environmental problems and inequities, rather than focusing on their symptoms alone. This is aligned with the call for structural transformation in the 2030 Agenda, as included in the opening paragraph of the 2019 IFAD Gender Action Plan. The [2023 guidelines for measuring gender transformative change](#) in

¹³ Walby S. 2004. *Mainstreaming de Género: Uniendo la teoría con la práctica*, https://americainagenera.org/wp-content/uploads/2014/07/doc_198_Mainstreamingdegenero.pdf

¹⁴ CGIAR Collaborative Platform for Gender Research (2019), Implementing Gender Transformative Approaches in Agriculture; FAO, IFAD and WFP. 2020. *Gender transformative approaches for food security, improved nutrition and sustainable agriculture – A compendium of fifteen good practices*. Rome. <https://doi.org/10.4060/cb1331en>

the context of food security, nutrition and sustainable agriculture published in the framework of the Rome Based Agencies Joint Programme on Gender Transformative Approaches also include a definition of GTAs. These guidelines highlight 'that gender transformative change must come from within the communities and societies where this change occurs and cannot be imposed from the outside (by development or research actors)'.

13. **Gender transformative programming tries to go beyond rhetoric and address the root causes of gender inequalities via interventions.** The glossary of the [2023 guidelines for measuring gender transformative change in the context of food security, nutrition, and sustainable agriculture](#) includes that: "Gender transformative programming involves taking a gender transformative approach to project and programme design, implementation, monitoring and evaluation throughout the project cycle. Programming strategies move beyond women's empowerment towards transforming unequal power relations and the social institutions which perpetuate and reinforce gender inequalities". Whether gender transformative interventions should involve radical change at societal and structural levels, or smaller incremental changes leading to transformation depends on the context, as it has to be accepted by communities and societies themselves.
14. Many international organizations express an aspiration to address the root causes of gender inequality, with some not explicitly mentioning gender transformative outcomes. A comparison of eight organizations undertaken for the TE GEWE¹⁵ revealed that while definitions vary slightly, all organizations emphasize that addressing root causes will not necessarily be implemented or result in changes within a linear manner as transformative change is usually the cumulative result of several interventions interacting with the context and social behavioral change.
15. **Gender parity in the UN, a commitment for several decades, emphasizes equal representation of men and women within the 47 to 53 percent margin.** This is outlined in the 2017 UN System-Wide Strategy on Gender Parity. Rather than adhering strictly to gender parity, IFAD's 2012 gender policy action area 4 sought to promote gender and diversity balance through supportive corporate approaches and procedures (see section II). Subsequent Human Resources 5 R action plans (2017-2021, 2022-2026) are explicit to improve gender parity. In IFAD, diversity is understood as acknowledgement and appreciation of a wide spectrum of identities, experiences, beliefs and other diversity dimensions, whether visible or invisible, inherent or acquired. These encompasses gender, race, ethnicity, nationality, age, language, sexual orientation, abilities and disabilities, culture, religion, profession, education, marital status, workplace experience, role, staff position (national/international) and contract modality (2021 IFAD Strategy on Diversity Equity and Inclusion).

C. Evaluation objectives and scope

16. The TE has two **objectives**: (i) to assess the development effectiveness and contribution to GEWE of IFAD interventions and (ii) to generate lessons and recommendations to enhance IFAD's future policies, strategies and interventions.
17. The **scope** of the TE is the period 2012-2023, with an emphasis from 2016, when the current IFAD's strategic framework was approved. IFAD's current Gender Action Plan was approved in 2019, hence it is premature for the evaluation to assess its results. Recent organizational changes, including internal processes changes, are assessed to see how they affect GEWE performance. Regarding gender results of country strategies, project investments, grants and other non-lending interventions, the evaluation prioritizes those designed after the approval of the

¹⁵ The choice was based on comparator organizations having a a gender strategy or a gender policy framework and similar developmental mandate and target groups to IFAD. The organizations are Care, OXFAM, Swedish SIDA, Canadian GAC, UNDP, FAO, WB and AfDB. WFP was later added for other analyses. See Annex IV for more details.

IFAD gender policy (2012)¹⁶. The evaluation covers the whole IFAD portfolio and corporate issues related to IFAD as an organization.

18. The TE has three overarching questions (see below), with sub-questions as included in the evaluation matrix in Annex I:

Box 3

Evaluation overarching questions

1. How relevant are IFAD gender priorities to the 2030 Agenda; how adaptive are they to changing environments, and how do they align with IFAD's transformational agenda and other contextual changes? (relevance, coherence)
2. What added value does IFAD bring to its various stakeholders, including poor rural women and men, when it comes to promoting GEWE? (relevance, effectiveness, impact, sustainability)
 - a. What are key outcomes (and trends) arising from the promotion of GEWE in IFAD interventions?
 - b. What progress has been made in IFAD gender transformative interventions?
3. To what extent is IFAD adequately equipped and living up to its ambition in terms of GTA promotion and complementarity of GEWE with other themes? (efficiency, environment and natural resources management, climate change adaptation)

D. Conceptual framework

19. The TE conceptualizes the linkages between IFAD's inputs and activities and the expected GEWE outcomes and spheres of influence: individual agency, intra-household power relations, collective agency in informal institutions and policy and legislation (See Figure below)¹⁷. Figure 1 is focused on the organizational level, with emphasis on the fit-for-purpose of IFAD to deliver on key areas of GEWE outcomes related to the objectives of its gender policy and action plans. In order to contribute to GEWE change, IFAD requires: (i) adequate human resources and gender capacities; (ii) sufficient financial resources allocated to GEWE; (iii) strategic direction in gender priorities; (iv) supportive internal operational processes; (v) functional accountability and reporting mechanisms; and (vi) conducive organizational culture, along with gender and diversity balance in its workforce.
20. A key element of IFAD's work on gender are **gender analyses** undertaken during the identification and design of strategies and programmes, such as country strategic opportunities programmes (COSOPs) and investment projects. These analyses should cover the key **gender gaps in each context** at individual and community level, within institutions and at national policy level. Various streams of GEWE outcomes promoted by IFAD have been mapped: (i) mainstreaming gender in all IFAD interventions (COSOPs, investment projects, grants and non-lending activities), recently in an integrated manner with other mainstreaming themes; (ii) the promotion of gender transformative approaches in a subset of interventions; (iii) improved capacities of IFAD staff and implementing partners, including government officers, to deliver the GEWE corporate agenda on the ground; and (iv) partnerships to test gender innovations to be scaled up by other partners and national government, including through policy engagement.

¹⁶ The report uses the term "interventions" to refer to the COSOP/country strategies and programmes, operations/project investments and grants. In addition, non-lending interventions/activities are assessed (knowledge management, partnership building, policy engagement).

¹⁷ It was developed by the IOE team by reviewing a range of GE theories of change, IFAD programme guidance and corporate documents with reference to gender and through discussions with IFAD gender experts. The ToC was validated during the TE design workshops in March 2023 and with IOE senior staff at key points during the evaluation. The TE acknowledges the difficulty of using conventional ToC for complex social behavioural change.

21. The results chain promoted by IFAD interventions, building from the gender analysis in the project designs, is depicted in Annex III, along with the overall assumptions of the evaluation. It shows how bundles of key IFAD project activities (GEWE practices) along with contextual factors, related to the projects themselves or to the country implementation context, interact to contribute to GEWE outcomes. The GEWE outcomes are mapped according to the three strategic objectives of the gender policy. The TE team added a fourth pathway of GEWE practices contributing to catalyse the use of spaces for rural women and men to reflect on how to challenge and change social norms that lead to gender inequality. In turn, GEWE outcomes contribute to four levels of spheres of influence or GEWE impacts: individual agency, more equal intra-household relationships, collective agency for more equal informal institutions and national policy and legislation addressing gender equality.

Figure 1
Evaluation conceptual framework

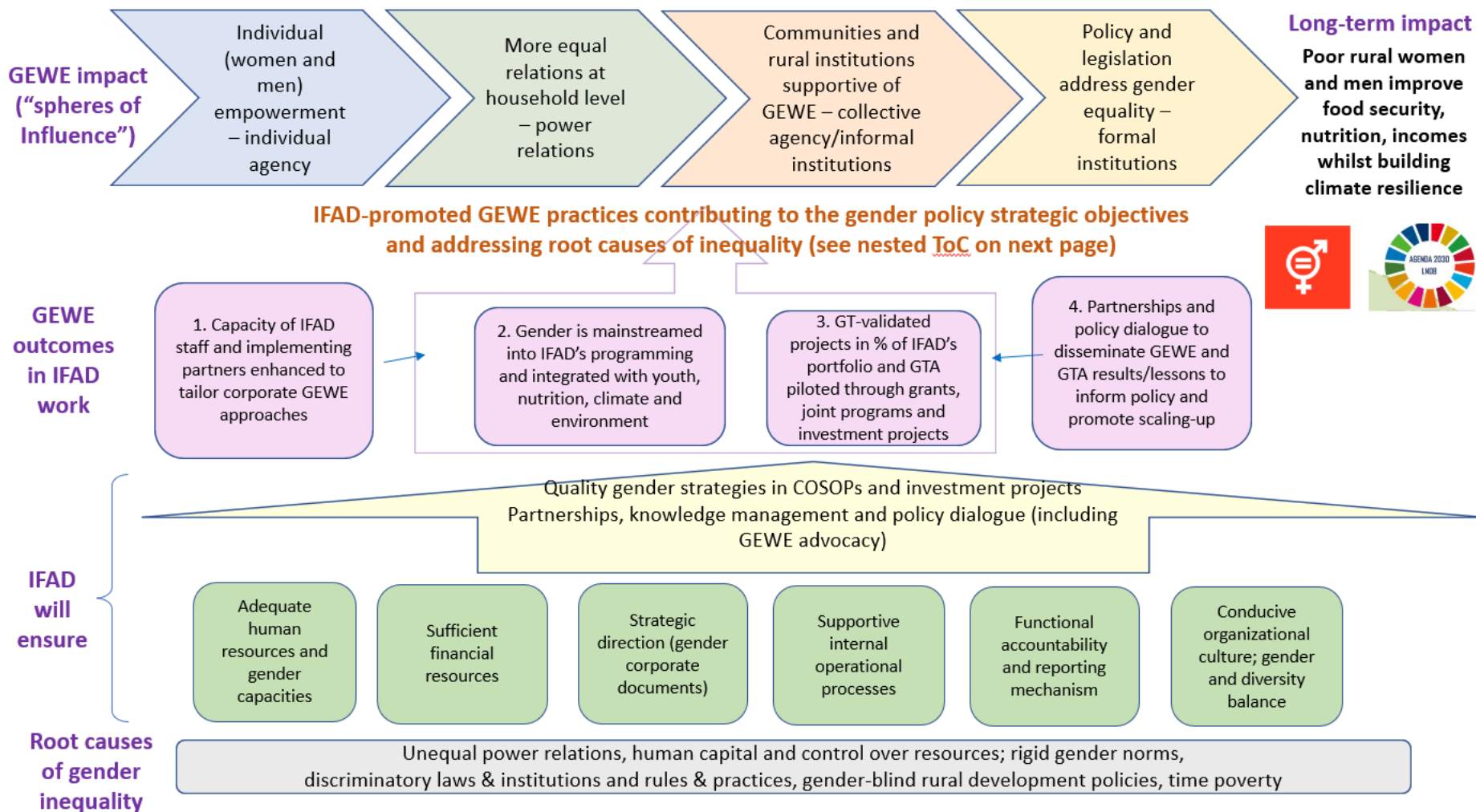

E. Evaluation methodology and process

22. The TE started with the analysis of available gender ratings of projects and information reported in Report on IFAD's Development Effectiveness (**RIDEs**), UN system-wide Action Plan on Gender Equality and the Empowerment of Women (**UNSWAP**) and Annual Report on Results and Impact of IFAD Operations (**ARRIs**) since the gender policy approval. It also conducted a synthesis of the GEWE information contained in the most recent **23 IOE evaluations**¹⁸. This was useful to identify the underreported dimensions which required primary data collection.
23. The analysis of the **evolution of the IFAD GEWE strategic approach** was conducted through desk review and interviews with key IFAD senior management, coupled with a "**fit for purpose assessment of IFAD as an organization**" following the methodology of a gender audit¹⁹. In addition to a thorough **gender literature review**, the evaluation compared key dimensions of the IFAD gender approach with **eight international organizations**²⁰.
24. Evidence from **eleven country case studies** was aggregated for the TE²¹. Cambodia, Cameroon, Kenya, Argentina and Sudan were chosen for field visits considering various criteria relevant to the TE evaluation questions.²² Field visits were conducted in all of them, but in NEN, Sudan field mission had to be cancelled last-minute due to civil political instability and took place virtually. It was complemented with an additional case study in Tunisia based on desk review and virtual interviews. In addition, to obtain more field evidence, the TE collaborated with other IOE teams having missions in 2023 in India, Mauritania, Ethiopia, El Salvador and Türkiye. A total of 19 COSOPs and 46 projects were covered by the case studies, including six GT-validated projects. Additional **25 COSOPs and 16 PDR** recently approved were reviewed using a gender analytical framework developed by the TE team. **Twelve gender grants and three supplementary-funded programmes with other institutions** were analysed through desk review and interviews to assess their value added in relation to innovation and linkages with IFAD's ongoing country programmes.
25. **Qualitative comparative analysis (QCA) was applied to all 28 evaluated investment projects** since 2012 (gender policy approval year) to understand which factors, alone and in combination, can lead to or influence the gender rating of IFAD project investments. A desk-review deep dive of investment projects which included **household methodologies** (especially Gender Action Learning System, GALS) and on *climate and gender*²³ provided extra information on GTAs and on mainstreaming various themes in IFAD interventions.
26. All the evidence from above sources and methodologies was triangulated with responses to an **electronic survey** (e-survey) from 178 Programme Management Department (PMD) IFAD's operational staff and consultants (26% of response rate), as well as 561 Project Management Unit (PMU) staff (40% of response

¹⁸ 4 country programme evaluations, 18 project completion validations and 1 project performance evaluation.

¹⁹ It covered human and financial resources; accountability and reporting; internal processes; and organizational culture, as per "good practice" gender audits conducted by other international organizations (See Annex IV).

²⁰ UNDP, FAO, World Bank, African Development Bank, Swedish SIDA, Canadian GAC, Care and OXFAM. WFP was added for certain analyses.

²¹ None of the eleven countries where the TE did a case study showed a deterioration in the UNDP Gender Inequality Index (UNDP GII) between 2013 and 2021 (last year available), which could have affected the performance of IFAD interventions. GII uses three dimensions: reproductive health, empowerment, and the labour-market. It is calculated country-wide, no information is available to distinguish between rural and urban men and women. See Annex XVI.

²² Regional representation (at least one case study per region), countries with a GT-validated project in the portfolio and other ongoing investment projects approved after the gender policy, countries with fragility situations and various income status.

²³ The TE mapped the gender focus of key climate funds and reviewed documents from IFAD's Adaptation for Smallholder Agricultural Programme (ASAP). It also used evidence from background documents of the IOE Thematic Evaluation of IFAD's Support for Smallholder Farmers' Adaptation to Climate Change, which covered 37 projects in 20 countries.

rate)²⁴. The TE used as a cross-cutting methodology a thorough **desk review** (Annex XXIV) and **interviews** with more than 300 key internal informants (see Annex XXV). The figure below depicts the main sources of evidence and evaluation building blocks. The methodology used in each of them is further explained in Annex IV.

Figure 2
Sources of evidence triangulated in the TE

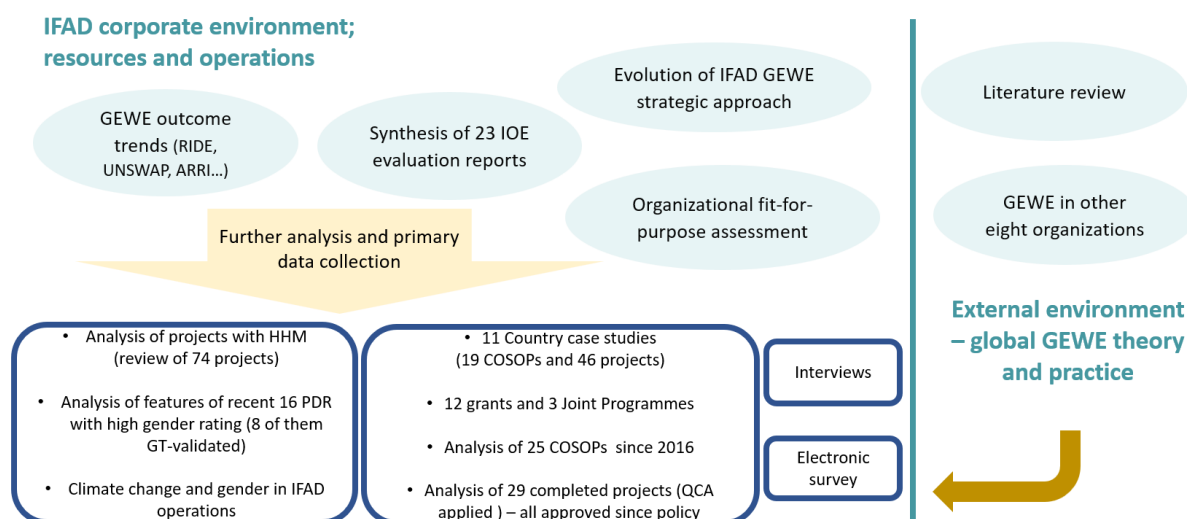

Source: elaborated by the TE team

27. The evaluation involved an **inception phase** (document review, preparation of the approach paper, including drafting and piloting data-collection instruments and stakeholder consultations). This was followed by the main **data collection and analysis phase, synthesis and reporting**. An emerging findings session was held with representatives from IFAD management before finalizing the draft. The final report, with the management response, will be presented at the 125th session of the Evaluation Committee in June 2024.
28. **Quality enhancement.** The TE was subject to internal IOE peer review. Two independent external senior advisers, Dr Diana Jupp and Dr Donna Mertens, provided comments to draft version of the approach paper and evaluation report. Their reviews are included in this report and their joint statement in Annex XXVI.

F. Evaluation limitations

29. **Important qualitative aspects of the participatory process to conduct gender analysis of IFAD interventions are poorly reported and gender outcome reporting is not sufficiently results-oriented.** The quality of gender information included in COSOPs and PDRs is variable and seldom includes explicitly the participatory processes conducted to fully consider important aspects for gender inclusion. The quality and detail of gender results and associated implementation challenges in key IFAD documents, such as supervision and completion reports, require considerable improvement (see section IV.A and Annex XIV). To mitigate this, the evaluation did a screening of project documentation, case studies, surveys, and interviews.
30. **The use of qualitative comparative analysis to explore under what circumstances did an IFAD project generated GEWE outcomes was constrained by various factors.** QCA provides algorithms to analyse data sets by

²⁴ The survey aimed to obtain feedback on the awareness, motivation, and capacity to work on GEWE, factors influencing GEWE performance at IFAD, on the relevance and effectiveness of IFAD's corporate approaches, availability of guidance and support, contribution of IFAD operations to GEWE, as well as feedback on non-lending activities in the context of GEWE and diversity in the workplace, etc.

using Boolean algebra logic operations to document varying configurations of conditions associated with observed outcomes. The information about some key factors could not be found for all the projects, despite contacting project teams in charge of the Project Completion Reports. For instance, outreach indicators could not be included in the analysis²⁵ and GEWE budget allocated at design and effectively used could not be accessed. Additionally, QCA cannot treat “middle” outcomes. Hence, twelve completed projects receiving a “moderately satisfactory” rating (4) could not be analysed using QCA. To mitigate this constraint, some completed projects were analysed through descriptive statistics.

31. **The systematic introduction of gender transformative programming is too recent to assess results.** Although gender transformative concepts were used in corporate reporting at IFAD before, it was not until 2019 that projects were formally validated as GT using standardized criteria, and none of these projects are complete to-date.²⁶ To mitigate this, the TE team analysed the quality of design of a sample of GT-validated PDRs and included related questions in the e-survey and interviews. It also included this as a criterion to choose country case studies and analysed the GEWE practices potentially contributing to addressing root causes of gender inequality in older projects.

²⁵ The number of women specifically targeted by projects vary from less than 2,000 (**Uruguay PPIR**, with a rating of 5) to more than 2,6 million (**Bangladesh CCRP**, with a gender rating of 4). The 29 completion projects targeted, on average, more than 260,000 women each (46% of the total targeted beneficiaries) and reached more women than those targeted (160% on average). The Targeting Evaluation Synthesis Note (ESN) discusses how the definition of direct and indirect beneficiary can confuse numbers and identified evidence of double counting.

²⁶ As analysed in Annex XXI, from 2013, IFAD started tracking the monetary value of loans and grants in relation to a six-scale gender rating. The highest gender score (6) of this gender-responsive budgeting exercise was considered in RIDEs as “gender transformative”. The TE considers “gender transformative programming” as the more ambitious commitment taken with the approval of the 2019 GAP.

Key points about the Evaluation background and rationale (Section I)

- Despite some improvement in relation to gender equality, as per the indicators for the Sustainable Development Goal 5 on Gender Equality and Women's Empowerment (GEWE), **gender gaps persist globally** in many areas.
- Extra analysis, time and funding efforts are required in rural areas to **address underlying gender inequalities** and to **foster equal opportunities** for enhanced benefits for IFAD's target population as a whole.
- This thematic evaluation (TE) assesses the **development effectiveness, results and performance of IFAD-funded interventions** in relation to their contribution to GEWE during the period 2012-2023.
- The evaluation is articulated around **three overarching evaluation questions**: (1) the relevance and coherence of IFAD gender priorities, (2) the performance of the promotion of GEWE through IFAD interventions, including efforts to catalyse gender transformative change, and (3) organizational the fit-for-purpose to deliver IFAD's high-level gender results.
- **Gender mainstreaming** as a process to assess the implications for women and men of any planned action at all levels is globally widely accepted since 1997. This is complemented in IFAD by proposals to address the root causes of inequalities between women and men (**gender transformative approaches** and **gender transformative programming**).
- **Gender parity** emphasizes equal representation of men and women. IFAD uses the term gender and diversity balance, where **diversity** is understood as the appreciation of a wide spectrum of identities of individuals, such as gender, ethnicity, nationality, abilities and disabilities and contract modality.
- The evaluation reconstructs a **Theory of Change** to analyse IFAD's organizational fit-for-purpose to deliver on key areas of GEWE outcomes. It also proposes a results chain of IFAD interventions related to the promotion of GEWE, building on identified GEWE practices. GEWE practices are conceptualized as bundles of project activities usually included in IFAD interventions that can lead to GEWE outcomes in rural areas.
- The evaluation triangulates evidence from many **different sources using a range of methodologies**, further explained in Annex IV. Weak reporting of key areas of gender analysis and limited information on gender in IFAD M&E systems were noted as constraints in the TE but were mitigated by additional primary data collection.

II. Promoting GEWE in IFAD and its evolution

33. This section provides a background on how IFAD has promoted GEWE. It looks at the evolution of gender priorities (including in key corporate documents), the types of interventions contributing to GEWE and the institutional arrangements for GEWE. The necessary context to frame the analysis included in Sections III, IV, V and VI is included in this Section.

A. IFAD corporate documents with reference to gender

34. **IFAD developed a Policy on Gender Equality and Women's Empowerment (GEWE) in 2012 (Gender Policy) following the 2010 IOE Corporate Level Evaluation (CLE) on IFAD's performance on GEWE.**²⁷ Three pillars or strategic objectives (SO) feature in the policy. The gender policy and the subsequent 2016 and 2019 Gender Action Plans (GAP)²⁸ include operational aspects (the loans and grants portfolio, knowledge management, policy engagement, communication, and capacity-building) and internal action areas (the promotion of gender equality within the organization). They are articulated in five action areas (see figure below).

Figure 3
The three pillars and the five action areas of IFAD's gender policy and the Action Plan

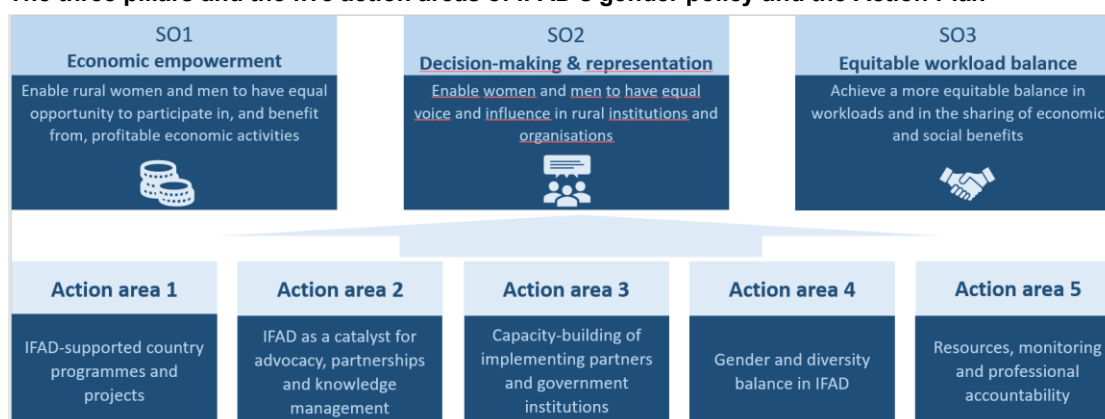

Source: TE team elaboration.

35. The first Action Area is related to gender mainstreaming in IFAD-supported country programmes and projects. The second area focuses on IFAD's role as a catalyst for GEWE (mainly through advocacy, partnerships, and knowledge management), including the promotion of gender policy dialogue in international fora. Cognisant that IFAD's operation model relies on government partners for implementation, the third action area is focused on improving the capacities of government institutions and implementing partners to support GEWE.
36. The 2012 Gender Policy included gender and diversity balance in IFAD as a fourth Action Area. This action area was not included in the 2019 GAP, as it is now in the Human Resources Division (HRD) 5 R Action Plan to Improve Gender Parity²⁹. The fifth action area is related to human and financial resources to support GEWE along with monitoring and professional accountability. These action areas and the corresponding indicators are included in Annex VI.
37. **Building on various years promoting gender transformative approaches (GTA) in its portfolio, IFAD confirmed its ambition to achieve real transformative gender impact in its 2016 Strategic Framework.** Since 2007,

²⁷ Annex V summarizes the main recommendations of the Corporate-level Evaluation (CLE) on GEWE and Management response and advance of implementation as of 2023.

²⁸ Mainstreaming Gender-transformative Approaches at IFAD – Action Plan 2019-2025, EB 2019/126/INF.6. April 2019.

²⁹ HRD action plans to improve gender parity in IFAD (2017-2021 and 2022-2026). The replenishment commitment of women accounting for at least 35 per cent of P5 posts and above was set in IFAD9 and was increased to 40 per cent. The 2021 Strategy for Diversity Equity and Inclusion sets the target at 50 per cent by 2030.

along with partner NGOs and donors³⁰, IFAD started experimenting and implementing GTAs such as Household methodologies (HHM), especially the Gender Action Learning System (GALS). Gender equality, empowerment and targeting is one of IFAD's five principles of engagement³¹ in its 2016 Strategic Framework which aims to enable inclusive and sustainable rural transformation (see box below). A 2016 document entitled gender mainstreaming in IFAD10, acted as a gender action plan. This along with the mid-term review of the Gender Policy confirmed IFAD's ambition to move beyond gender mainstreaming. In 2017, an IOE-led synthesis report noted that many GEWE practices were being implemented in projects providing results that could lead to transformative change³². Over the years, IFAD replenishment commitments began to include gender-transformative targets (See Annex VI).

Box 4

IFAD's intention to achieve real transformative gender impact.

The Strategic Framework outlines that apart from promoting economic empowerment for both rural women and men, complemented by efforts to reduce the labour burden of rural women and increase their voice in decision-making at all levels, IFAD will look to move beyond mainstreaming and scaling up in order to achieve **real transformative gender impact**. Through **investments** and **policy engagement** IFAD will **address the underlying root causes of gender inequality** to ensure equal access for women to productive assets and services and to employment and market opportunities.

Source: IFAD Strategic Framework 2016-2025 (pages 18-19).

38. **Following the 2030 Agenda, IFAD's Gender Action Plan in 2019 emphasises the need for structural transformation.** IFAD's updated Gender Action Plan (GAP) was approved in May 2019 and runs until 2025³³. The GAP, entitled *Mainstreaming Gender-Transformative Approaches at IFAD*, confirms the need to address the root causes that generate and reproduce inequalities and problems, rather than addressing symptoms alone. Apart from the call for 'bold and transformative steps' to achieve the 2030 Agenda, the need for an integrated approach to gender, youth, nutrition, and climate for maximum impact is outlined³⁴. In November 2019, IFAD's Executive Board approved IFAD's Framework for Implementing Transformational Approaches to Mainstreaming Themes: Environment and Climate, Gender, Nutrition and Youth.³⁵ This framework clarified the interactions between IFAD's mainstreaming themes towards rural household transformation and resilience within the emerging awareness of food systems.³⁶ The figure in Annex VII reconstructs the timeline of approval of key IFAD corporate documents with reference to gender during the evaluation period.

B. GEWE in IFAD interventions

39. **All IFAD country strategic opportunities programmes (COSOPs) are required to mainstream gender.** GEWE issues should be included when framing strategic choices about IFAD operations in a country, and when identifying opportunities for IFAD financing and facilitating management for results.³⁷

³⁰ CARE, Oxfam, Hivos and PROCASUR, while Swedish SIDA as one of the main donors supporting HHM.

³¹ The other principles underlying the Strategic Framework are innovation/learning/scaling up and partnerships.

³² Annex V summarizes the main recommendations of the evaluation synthesis on GEWE and Management response and advance of implementation as of 2023.

³³ The development and implementation of a new action plan on gender is included among the IFAD13 commitments and targets (IFAD13/4/R.2, December 2023).

³⁴ In 2017, IFAD published Looking ahead: IFAD in the context of the 2030 Agenda for Sustainable Development, which outlined how Agenda 2030 required bold and transformative steps to shift the world towards a sustainable and resilient path. Paragraph 16 stated that projects must also address the cross-cutting themes of nutrition, gender, and climate.

³⁵ <https://www.ifad.org/en/-/framework-for-implementing-transformational-approaches-to-mainstreaming-themes-environment-and-climate-gender-nutrition-and-youth>

³⁶ In preparation for the UN Food Systems Summit (2021), the Rome-based agencies (RBA) started including in their frameworks the interconnected systems and processes that influence nutrition, food, health, community development, and agriculture.

³⁷ Including other dimensions of diversity which may be the basis of discrimination against women, such as disability, age, ethnicity/race, marital status, among others.

Guidance and practice for gender mainstreaming in COSOPs have evolved during the evaluation period. COSOPs used to include a stand-alone appendix on gender and a checklist for gender inclusion was used for COSOP formulation.³⁸ New Guidelines in 2015 discontinued the use of a separate appendix. COSOP guidance does not highlight the move towards gender transformative programming. Gender equality is now covered under the Social, Environmental and Climate Assessment (SECAP) background study appendix, attached to the COSOP, which describes the target group and the five IFAD priorities (environment, gender, nutrition, youth, and marginalized people), see box below.

Box 5

Gender issues in IFAD's SECAP (2021)

The SECAP procedures were updated in 2016 for improved targeting, in **2017 to incorporate GEWE**, in 2019 to strengthen consideration of issues related to indigenous people, and in 2021 (current version). The 2021 Procedures extend **beyond risk mitigation to identify opportunities for maximizing development gains by mainstreaming** environmental, **social** and climate issues throughout the project cycle³⁹. SECAP outlines how to **manage risks and impacts, integrating priorities** into IFAD investments through environmental, **social** and climate due diligence, including procedures for integrating into projects among other risk related assessments. In the 2021 version, a new aspect involves specifying requirements for borrowers, recipients and partners to **prevent and address gender-based violence**, including sexual harassment, exploitation and abuse. It emphasizes the recognition of gender-specific adverse impacts in mainstreaming gender which implies acknowledging the differential effects of rural transformation on women and men.⁴⁰

Source: SECAP, 2021.

40. **Household methodologies (HHM) have been the most adopted gender transformative approach included in IFAD projects.** By 2020, more than 100,000 people had engaged in HHMs in IFAD-supported programmes in 28 countries⁴¹. These participatory methodologies for community-led empowerment aim to support livelihood planning, gender justice and rural transformation. They share some underlying hypotheses: (i) existing gender norms, such as the division of responsibilities among household members, are directly related to the level of women's empowerment; (ii) unequal power relations between women and men can result in failures to make the best decisions leading to inefficiencies in family farming. Other less frequent HHM included in IFAD's interventions are presented in Annex VIII. Additionally, *Cerrando Brecha* ("closing the gap") has been used in IFAD since 2000 in 15 IFAD-funded projects in several Latin American countries, with a particular concentration in El Salvador. The approach intentionally works towards closing gender gaps within rural producers' organizations.⁴²

Box 6

Characteristics of Household methodologies, such as Gender Action Learning System

HHM constitute a family of diverse participatory methodologies that seek behavioural change to promote gender equality and livelihood development. They target the household level rather than the individual or the community. GALS is a community-led participatory methodology. It starts at the individual level, by encouraging women and men to develop their own vision, which serves as a basis and

³⁸ 2006 COSOP guidelines.

³⁹ According to SECAP, mainstreaming gender implies recognizing the different ways in which issues related to rural transformation affect women and men.

⁴⁰ SECAP 2021 includes a definition for gender equality and GBV, but not for gender mainstreaming or gender transformative approaches.

⁴¹ 2019 IFAD HHM stocktaking exercise, 2020 JP GTA compendium on GTA good practices.

⁴² External facilitators apply different tools to the board of directors of rural organizations and to producers/organizations members. It then calculates scores for men and women (baseline situation), identifies affirmative actions/gender strategy of the rural organization to reduce the existing gender gaps and measures progress (ProGénero, 2003. "*Cerrando brecha, manual*", *TE interviews and IFAD, 2023. Cerrando Brecha summary in JP GTA*).

catalyst for cooperation within the household and in the community. It uses visual tools and is facilitated by peer trainers (GALS champions).

Source: SIANI, 2013; IFAD, 2014; Farnworth et al., 2018; IFAD, 2022.

41. **The project design process underwent streamlining in 2018, altering how GEWE-related interventions are designed, documented and reviewed.** Previously, technical inputs were provided through Country Programme Management Teams (CPMTs). Design reports were then reviewed during Quality Enhancement by the Policy and Technical Advisory (PTA) division technical experts, then Quality assurance by the Quality Assurance Group (QAG). Since 2018, technical inputs and support are provided through Project Delivery Teams (PDTs).⁴³ A design review meeting is conducted to assess the draft PDR, informed by an arms-length QAG review, two peer reviewers, one from PMD and one from Strategy and Knowledge Department (SKD), and procedural experts within IFAD. IFAD Operational Guidelines at the design stage have recently been expanded to elaborate on the compliance criteria for a gender transformative project (see Annex IX).
42. **IFAD Operational Guidelines have also been further developed to offer additional information on assessing GEWE progress during implementation and completion.** The gender marker system has been instrumental, akin to other organizations, for gender mainstreaming in IFAD's operations.⁴⁴ Performance score descriptors guidance provides detailed information for rating a project from 6-highly satisfactory to 1-highly unsatisfactory, see table below. Similarly, the Project Completion guidelines refer to the Evaluation manual to assess to which extent IFAD interventions have contributed to significant GEWE.

Table 1
IFAD Gender marker

Rating: 1, HU	Rating: 2, U	Rating: 3, MU	Rating: 4, MS	Rating: 5, S	Rating: 6, HS
No attempts to address gender concerns or mainstream gender into project activities	Focus on gender issues is vague and erratic	Some limited measures to strengthen gender focus, some efforts to facilitate the participation of women	Partial contribution to addressing gender needs, and promoting GEWE, addressing two out of the three gender policy objectives	Significant contribution to addressing gender needs and achieving GEWE, addressing all three gender policy objectives	Significant contribution to gender transformative, addressing all three gender policy objectives and engaging in policy dialogue. ⁴⁵

Source: Performance score descriptors (Annex I of the Project Implementation guidelines), November 2020.
HU: highly unsatisfactory, U: unsatisfactory, MU: moderately unsatisfactory,
MS: moderately satisfactory, S: satisfactory, HS: highly satisfactory.

43. Since 2013, different divisions of IFAD have been trying to improve the measurement tools to assess gender equality and women's empowerment (see box below and Annex X). The 2019 Action Plan discusses the utilization of Women's Empowerment in Agriculture Index (WEAI), case studies, and participatory and qualitative research to supplement standard M&E data. The Action Plan identified

⁴³ Introduced and refined by the President's bulletins PB/2018/04 and PB/2021/11.

⁴⁴ Many organizations reviewed use a gender marker to measure the integration of gender in their programs and/or strategies: CARE's marker uses a scale from 0 (gender unaware) to 4 (gender transformative), UNDP marker ranges from 0 (no contribution to gender equality and the empowerment of women) to 3 (gender equality as the principal objective); WFP uses the Inter-agency Standing Committee (IASC) gender and age marker; the World Bank uses a gender tag at design to indicate Bank operations that used diagnostics to identify a gender gap.

⁴⁵ Highly satisfactory (gender rating 6) also adds project's contribution to **gender transformative changes**, those with capacity to address the root causes of gender inequalities -including prevailing social norms, attitudes and behaviours, discrimination and social systems to ensure equal access for women to productive assets and services, and to employment/market opportunities.

the absence of an institutional agreement on measuring women's *empowerment* as a risk for IFAD.

Box 7

Evolution of measurement of empowerment (and GEWE) at IFAD

- 2013: The Research and Impact Assessment (RIA) Division of IFAD started efforts to enhance the measurement of women's empowerment as part of measuring the impact of projects. Drawing on work by IFPRI, RIA proposed two simplified versions of the Women's Empowerment in Agriculture Index (WEAI): the **reduced WEAI (R-WEAI)**⁴⁶ and the **integrated WEAI (I-WEAI)**.⁴⁷
- 2015-2017: R-WEAI featured in **IFAD Results and Impact Measurement System (RIMS)** annex signaling efforts to refine IFAD's M&E on GEWE⁴⁸.
- 2020: IFAD mandated the calculation of an **empowerment indicator** as part of the IFAD Core Outcome Indicators for GT-validated projects at baseline and endline.
- 2023: The Rome-based agencies issue new **guidelines on measuring gender transformative change** in the context of food security, nutrition and sustainable agriculture, following a virtual expert consultation.⁴⁹
- 2023: IFAD13 proposes **women's empowerment** as an impact indicator in IFAD's Results Management Framework (RMF).

Source: TE's team based on desk review and interviews⁵⁰.

44. **Additionally, IFAD has funded and managed grants to test innovations and approaches expected to be linked with IFAD programmes.** Each year priorities related to IFAD replenishments and IFAD's strategic priorities are outlined in grant calls. All grants are expected to mainstream gender regardless of the grant focus.⁵¹ A 'gender' grant requires endorsement of the regional division and the gender team, and often covers a range of countries. The distribution of gender grants by region and recipient has changed over time. The TE GEWE examined 12 gender grants and found that LAC and ESA countries received more grants from 2012-2015 than other regions (10 and 9 respectively), and ESA countries concentrated the gender grants in the period 2016-2022. NEN did not receive any gender grant in this second period. The recipients of gender grants shifted from UN Agencies and NGOs from 2012-2015 to CGIAR from 2016-2022, with an average of US\$ 1.8 million per grant for the 2012-2022 period.⁵² The grant for IFPRI to assess the gendered impact of six projects is the biggest grant in this the period (See Annex IV).
45. **Building on the strengths of different agencies, special IFAD interventions are channelled through supplementary funding.** For instance, Joint Programmes (JP) should enable IFAD and partners to implement a harmonized results framework, work plan and budget.⁵³ See box below and Annex IV for an

⁴⁶ The R-WEAI, as an attempt to find a cost-effective empowerment indicator, underwent testing in baseline studies for projects with funds from the first phase of JP-RWEE.

⁴⁷ The I-WEAI was developed through a grant executed by IFPRI "Assessing the Gendered Impact of Rural Development Projects", (2018-2022), producing 6 ex-post impact assessments of IFAD-funded projects (an additional one was done through another grant by C4ED). Most of these projects were approved before the IFAD gender policy, and used for IFAD11 impact assessment. Other IAs by RIA used a simplified version of WEAI.

⁴⁸ In 2017, IFAD revisited its results framework, which ended up in the development of the core indicators framework and guidelines. The **Core Indicators (CIs) framework** aims at measuring and reporting results project achieve at the output and outcome levels. There are 45 outreach, output and outcome indicators, linked to strategic objectives the SDGs. As of July 2023, the current version of the guidelines is from October 2021.

⁴⁹ <https://doi.org/10.4060/cc7940en> The guidelines suggest capturing **incremental changes along pathways** towards empowering women and achieving gender equality. Users of these Guidelines are strongly encouraged for the creation of **context-specific indicators** in collaboration with the people and organizations.

⁵⁰ One of the reviewed gender grants helped the piloting of WEAI in **Tunisia**, for the first time in an Arab country.

⁵¹ IFAD developed new grants procedures in 2023 to simplify the grant application process. Apart from specific 'gender grants' (those managed by the IFAD gender team).

⁵² This average does not consider the smallest one for the Huairou Commission (a women-led grassroots group). The TE did not find any systematic reason for the changes in the allocation of gender grants across regions or recipients during the evaluation period. Some interviewees mentioned the (more or less) proactive role of certain country directors, the endorsement at regional front offices or blockages related to language. In 2021 the new Grants Policy established a competitive process during each replenishment cycle, based on thematic areas, which has been further simplified in January 2023.

⁵³ Adapted from UN Sustainable Development Group, 2023. [Guidance Note on a New Generation of Joint Programmes](#)

overview of the three supplementary funded programmes on gender equality during the evaluation period.

Box 8

Programmes on gender equality with supplementary funding during the evaluation period

The 'Joint Programme: Accelerating Progress Towards Rural Women's Economic Empowerment' (JP RWEE) is a partnership between UN Women, and the three Rome-based agencies (RBA), FAO, IFAD and WFP. Its first phase started in 2014 (with funding from Norway and Sweden) and was implemented in Ethiopia, Guatemala, Kyrgyzstan, Liberia, Nepal, Niger and Rwanda.⁵⁴ The second phase started in 2022 (funded by Sweden) and covers Tanzania, Niger, Tunisia and Nepal and some Pacific Islands. The JP RWEE works with national governments to advance policy change, with local government to ensure **policy implementation, and at the **local level** to tackle unequal power relations and social norms. Phase I of JP RWEE had 35 million USD financing, with 11 percent from IFAD. Phase II has a budget of 31.7 million USD, with 13.7 percent from IFAD, as per the 2022 financial report.**

FAO, IFAD and WFP are implementing the Joint Programme on Gender Transformative Approaches for Food Security, Improved Nutrition and Sustainable Agriculture (JP GTA). With USD 5 million finance from the European Union, this JP began in 2019 and is aiming to contribute to the achievement of SDG 2 (zero hunger) through addressing the root causes of gender inequalities by **testing gender transformative programming. With a focus on knowledge generation and learning, other key components include field-testing, capacity building and institutional and policy engagement. The focus countries are Ecuador and Malawi.**

The Bill and Melinda Gates Foundation (BMGF) is funding (USD 16 million) the Gender Transformative Mechanism (GTM): Improving climate resilience and rural people's wellbeing by promoting gender transformative results. Initiated in 2021, the GTM is to support IFAD's partner governments increase investment, capacities, and activities to achieve **gender transformative results at scale in rural areas whilst also strengthening climate resilience. By 2030, the aim is to reach over 20 million rural people across 27 projects and 20 countries. Successful interventions should be **scaled up** through IFAD's investment portfolio with knowledge generated to provide evidence-based **policy engagement**. The GTM expects to attract climate finance when decision makers see the benefits of gender transformative results. The GTM is working on specific projects in Burkina Faso and in India with intention to start in Ethiopia.**

Source: Documents from the three programmes.

C. IFAD efforts to deliver GEWE

46. **The concept of gender mainstreaming requires that all IFAD staff contribute to the implementation of the gender policy.** Gender mainstreaming in IFAD as an organization means that gender equality should be an integral part of the organization's strategy, policies and operations. In other words, it should be fully reflected, along with other core priorities, in the mindset of IFAD's leadership and staff, its values, resource allocations, operating norms and procedures, performance measurements, accountabilities, competencies, and its learning processes.
47. **The main human resources to meet IFAD's gender-related mandate⁵⁵** include four main components: (1) the gender and social inclusion team with global responsibility; (2) staff with regional responsibility for gender and social inclusion; (3) gender focal points;⁵⁶ and (4) a senior management gender champion. In addition, there are two supporting components: the gender communities of

⁵⁴ According to interviews, countries are invited to submit a concept note which are selected according to their quality.

⁵⁵ The human resources to meet IFAD's gender-related mandate are referred to in IFAD gender corporate documents and in the UNSWAP as "the gender architecture". To ensure clarity, this evaluation refers instead to human resources.

⁵⁶ Not a full-time role. The UNSWAP recommends 20 per cent of staff time is dedicated to gender-related work. In IFAD the gender focal point (GFP) role is present in most divisions and in a minority of decentralised offices. In IFAD-supported projects, gender focal points in PMUs may be actual gender and social inclusion officers or a role allocated to a PMU member with another technical role.

practice; and gender and social inclusion consultants. Their roles and responsibilities are further outlined in Annex XI.

48. The gender and social inclusion team was formally located in the Policy and Technical Advisory division (PTA) under the Programme Management Department (PMD).⁵⁷ Internal structural reorganization in 2018 dismantled PTA and saw the creation of the Strategy and Knowledge Department (SKD) comprising the Environment, Climate, Gender and Social Inclusion Division (ECG), and other divisions. ECG is divided into two main clusters, one on environment and climate, and the other on social inclusion. The latter includes the gender and social inclusion team (also in charge of targeting and disability inclusion) as well as teams on youth, nutrition, and indigenous peoples.
49. The main sources of financial resources to support IFAD's gender-related work come from (i) core budget resources, from the administrative budget (staff and non-staff costs) and from the programme of loans and grants, which come from IFAD replenishment funds; and (ii) supplementary funds, which are grant resources received from Member States and other donors for innovative initiatives, studies, technical assistance and to support IFAD's Junior Professional Officer programme.

⁵⁷ The Policy and technical advisory division (PTA) aimed to *improve the quality of the design and implementation of its policies, country strategies and projects.*

Key points about the Evolution of IFAD promotion to GEWE (Section II)

- Key **IFAD corporate documents with reference to gender** are the 2012 Policy on GEWE, the 2016 Action plan on gender mainstreaming, and the 2019-2025 Action Plan to mainstream gender transformative approaches at IFAD.
 - They include **three strategic objectives** on (1) economic empowerment, (2) decision-making and representation, and (3) equitable workloads and sharing of benefits.
 - They include **five action areas**: (1) IFAD-supported country programmes and projects; (2) IFAD's role as a catalyst for advocacy, partnerships, and knowledge management; (3) capacity building of implementing partners and government institutions; (4) gender and diversity balance; and (5) corporate human and financial resources and monitoring and accountability systems;
- IFAD mainstreams gender in all its **interventions** (Country Strategic Opportunities Programmes or COSOPs, investment projects, grants and non-lending activities, NLA) and has developed various **guidance and tools**, such as the gender marker to monitor the promotion of GEWE during project implementation and completion.
- Since 2016, in addition to gender mainstreaming in interventions, IFAD has moved to focus strongly on how to **bring about transformative change** by putting in place tools to address the underlying root causes of gender inequality mainly in investments and also to some extent in **policy engagement**. IFAD-supported projects have mainly used **household methodologies** to tackle the root causes of gender inequality;
- **Gender grants** are typically used to test innovations and different approaches, such as the ones to pilot and scale household methodologies. Some special IFAD interventions have been channelled through three **supplementary-funded programmes on gender** during the evaluation period (JP RWEE, JP GTA and GTM) and these have built on the strengths of the different agencies involved;
- IFAD has taken an iterative approach to improving **tools to measure women's empowerment**;
- The 2019 Gender Action Plan and IFAD's Framework for Implementing Transformational Approaches to Mainstreaming Themes: Environment and Climate, Gender, Nutrition and Youth called for an **integrated approach to gender, youth, nutrition, and climate** for maximum impact;
- **Gender mainstreaming in IFAD as an organization** means that gender equality should be an integral part of the organization's strategy, policies and operations. It also means that all IFAD staff contribute to the implementation of the gender policy.

III. Relevance and coherence of IFAD support to GEWE

50. This section firstly looks at the relevance of IFAD's gender priorities with regard to the external development context (III.A). Section III.B verifies the internal coherence of the gender policy and action plans against IFAD's Strategic Framework 2016-2025 and other policies and strategies (linked to assessment of the strategic direction needed for gender work). Section III.C presents key findings from a comparison of gender approaches and institutional set-up with other international organizations. Finally, Section III.D provides an analysis of the relevance of how GEWE is promoted in IFAD interventions, encompassing an assessment of the quality of the gender strategies employed in COSOPs, PDRs and investment proposals of two non-sovereign operations. This Section triangulates evidence from desk reviews, interviews, the country case studies, the review of COSOPs and investment project designs and the comparative analysis with other organizations.

A. Alignment of gender priorities with Agenda 2030 and global policy debates

51. **IFAD's Gender Policy was developed prior to Agenda 2030 but remains relevant to the SDGs.** It aligns with gender mainstreaming as a globally endorsed strategy to achieve gender equality and the empowerment of women and girls. GEWE is a condition to achieve other goals (including SDG 1 and SDG 2), and all SDGs are expected to produce sex disaggregated data. Although IFAD does not report formally against SDG 5 it does contribute to some of its targets and indicators (See Annex VII).⁵⁸ For instance, the first objective of the IFAD gender policy (SO1) on economic empowerment contributes directly to SDG target 5a, although there is less focus in IFAD on improving access to and control over land and other forms of property, which is included in this SDG target⁵⁹.
52. IFAD corporate documents with reference to gender do not put sufficient emphasis on the improvement of legal frameworks for gender equality and specifically to address some of the root causes of inequality. The 2012 Gender Policy expects an increase in engagement on gender issues in policy dialogue and scaling up.⁶⁰ This is of relevance to SDG target 5c which focuses on strengthening policies and enforceable legislation to promote of GEWE. However, it is only from 2019 that it is expected that GT-validated projects should systematically plan for policy engagement on GEWE.
53. **The integrated emphasis articulated in IFAD gender priorities effectively addresses the interconnected challenges acknowledged in global discussions on climate, food security and nutrition.** IFAD has developed various financing instruments, including the Adaptation for Smallholders Agriculture Programme (ASAP), which acknowledge the connections between addressing climate change and mitigating gender inequalities. This is well aligned to the gender policies and action plans developed by core multilateral climate financing instruments such as GCF and GEF.⁶¹ IFAD is contributing to important debates on gender and climate change (e.g., through *the BMGF-funded GTM*) and the need for rural transformation and the focus on food systems, and nutrition with the Rome Based Agencies (the EU-funded JP GTA). IFAD has jointly developed the publication *State of Food Security and Nutrition in the World in 2023*, which confirms the

⁵⁸ SDG 5 aims to address the pervasive gender inequalities that exist globally and to promote the full and equal participation of **women and girls** in all aspects of society.

⁵⁹ IFAD has been tracking since 2017 the number of male and female beneficiaries who registered ownership or user rights over national resources, recently changed by the number of beneficiaries who increased secured access to land.

⁶⁰ Under Action Area 2, IFAD as a catalyst for advocacy, partnerships and knowledge management.

⁶¹ The Green Climate Fund (GCF) included gender requirements in some core operational policies (including its framework for accreditation and results measurement) and requested mandatory gender assessment and program-specific gender action plans for funding proposal approval. Although commendable in principle, some have found a gap in the GCF intention and practice. See for example 2021 [Heinrich Böll Stiftung Washington, DC and Gender Action](#),

relevance of gender equality for food security and nutrition, particularly in rural areas.⁶² The endorsed Voluntary Guidelines for Gender Equality and Women's and Girls' Empowerment developed by the Committee on World Food Security (CFS), of which IFAD is a member, also emphasize the positive relationship between women's and girls' empowerment and achieving food security and nutrition as a key principle.⁶³

54. **The move in programming to tackle the root causes of gender inequality is highly relevant to IFAD's mandate and aligned with international efforts.** The UN Commission on the Status of Women in the 2018 Agreed Conclusions had a focus on GEWE for rural women and girls. It mentions the need to understand and address root causes of gender inequality practices and stereotypes that perpetuate discrimination against women and girls.⁶⁴ However, there is less explicit attention to international debates recognising male inequalities. Most Member States endorsed addressing the root causes of gender inequality, acknowledging that challenging entrenched gender norms leads to a positive change for agriculture and food security. However, some interviewees during this evaluation noted that a few Member States demonstrated reticence during negotiations of the Voluntary Guidelines with regard to the concept of GTA, often due to a lack of understanding of the concept⁶⁵.

B. Coherence with IFAD priorities and reforms

55. **IFAD's Gender Policy is broadly aligned with corporate priorities, but some aspects require updating.** IFAD's Gender Policy was well aligned with the overarching goal of the IFAD Strategic Framework 2011-2015 at that time. IFAD's latest Strategic Framework (2016-2025) states that for gender equality, IFAD will remain guided by its Gender Policy and that IFAD will consolidate its position as a leading agency on innovative measures to promote rural women's empowerment. The three strategic objectives (SO)⁶⁶ and action areas in the Gender Policy and Action Plan (see Figure 3 in Section II) are aligned with other key corporate documents and with the commitments included in the replenishments. Nonetheless, aspects such as GTAs and GT programming are not formally included in the policy. All action areas are still relevant, but some would require additional resources to be adequately implemented (such as IFAD's role as a global catalyst for GEWE⁶⁷ and capacity-building of implementing partners and government institutions, see Section VI).
56. The Gender Policy and Gender Action Plan did not explicitly consider how gender intersects with other social identities and axes of power. The 2012 Gender Policy references the 2006 Policy on Targeting and the 2009 Policy on Engagement with Indigenous Peoples. The 2006 Targeting Policy placed prominence on addressing gender differences with a special focus on women within all identified target

⁶² SOFI 2023, p.120: Women's empowerment is one of the most important pathways through which food production policies can have positive effects on access to nutritious foods and, in turn, on food security and nutrition outcomes, particularly in rural areas.

⁶³ <https://www.fao.org/3/nn162en/nn162en.pdf>. Statement based on June 2023 draft presented at the 51st session of the Committee on World Food Security in October 2023. See paragraphs 20, 21 and 27.

⁶⁴ <https://www.unwomen.org/sites/default/files/Headquarters/Attachments/Sections/CSW/62/CSW-Conclusions-62-EN.PDF>

⁶⁵ In some cases, it is misunderstood as relating to sex reassignment surgery by which a transgender or non-binary person's physical appearance and functional abilities are changed.

⁶⁶ SO 1 promote the **economic empowerment** to enable rural women and men to participate in and benefit from profitable economic activities; SO 2 enable women and men to have **equal voice and influence** in rural institutions and organizations; and SO 3 achieve a **more equitable balance in workloads** and in the **sharing of economic and social benefits** between women and men.

⁶⁷ As identified in the review of comparable organizations and their focus on GEWE, acting as a catalyst and role model is still relevant and most comparable organizations take on this role. Global advocacy on GEWE helps to ensure that rural women's rights are on the agenda and their rights upheld.

groups, with a particular focus on women headed households. Intersectionality is more clearly outlined in the Poverty Targeting Policy 2023⁶⁸ and recent literature.

Box 9

Concept of intersectionality applied to gender.

Women and men's experiences are not homogenous and access to resources and decision making varies depending on their social position within a community. For example, experiences differ as a wealthy woman/ man from a dominant caste or ethnic group, compared to a poor or widowed woman/man, a young wife/ husband in an extended family, or a rural woman/man, or women with disabilities.

Source: Literature review, JP-GTA guidelines (2023)⁶⁹

57. **Considerations of GEWE across IFAD policies and practices were varied.**

The desk review conducted by the TE found that many recent policies mention the relevance of IFAD's commitment to gender equality, such as the Disability Inclusion Strategy (2022-27); the Policy on Engagement with Indigenous Peoples (2022); the Action Plan on Nutrition (2019-2025). However, some could underline the relevance to GEWE and/or intersectionality issues more clearly. For example, the Action Plan on Youth (2019) has limited recognition of the specific issues young women face. According to IFAD's strategy on fragility, GEWE is one of the entry points for IFAD's work in fragile contexts, supporting men's and women's roles in building resilient communities. In such contexts, IFAD programmes need to be based on systematic fragility assessments, simplified project designs, adaptive management and flexible delivery (including third-party implementation, such as the use of local NGOs)⁷⁰.

58. Some of IFAD's thematic policies do mention gender, mainly in terms of barriers for women (Inclusive Rural Finance Policy, 2021 and IFAD strategy and Action Plan on Environment and Climate Change, 2019-2025), or the need to understand the gendered aspects (Strategy on Biodiversity (2022-2025)). Whilst it is recognised that in many instances women can face disproportionately higher vulnerability, it would be expected that policies and strategies could also move beyond a vulnerability focus and underline the relevance of **women as agents of change in rural areas**. Apart from the Strategy for Engagement in Small Island Development States (2022-2027) there is little commitment to GTAs in many of IFAD's policies or strategies.

C. **Comparison of IFAD's GEWE approach with other international organizations.**

59. A comparative analysis undertaken for this TE analysed data from eight organizations (CARE, OXFAM, SIDA, GAC, UNDP, FAO, WB and AfDB) to identify how they address GEWE across different aspects of their mission and work. These organizations were chosen because they have a similar mandate and target groups to IFAD, and present interesting features which could inspire IFAD. The following text focuses on areas where IFAD's approach differs and/or can learn from others (additional findings in Annex XII).
60. **IFAD is one of the few international organizations with a gender strategic objective to improve the workload balance between rural women and men.** All eight comparator organizations include objectives similar to two in IFAD's gender policy ('economic empowerment of women' and 'decision-making/representation of women'), while 'equitable workload balance' (the third strategic

⁶⁸ The 2023 Poverty Targeting Policy recognizes that the application of targeting is context-specific but should be consistent with the overarching statement that when mainstreaming women's economic empowerment, the target group must be women who are living in or vulnerable to poverty.

⁶⁹ Source: FAO, IFAD, WFP & CGIAR GENDER Impact Platform. 2023. Guidelines for measuring gender transformative change in the context of food security, nutrition and sustainable agriculture. Rome, FAO, IFAD, WFP and CGIAR. <https://doi.org/10.4060/cc7940en>

⁷⁰ IFAD's strategy for engaging in countries with fragile situations (2016), Special Programme for countries with fragile situations: operationalizing IFAD's fragility strategy (2019).

objective at IFAD) is not widespread among other organizations (except for FAO). Whilst there may not be explicit mention of women's heavy workload or unpaid care and domestic work in other organizations' GEWE strategy as such, organizations have initiatives that focus attention on, or reduce, women's work burden, including through advocacy, gender and time-use studies, and supporting labour-saving technologies.

61. **IFAD is among the international organizations that have played a role in innovating gender related work.** Some organizations include specific themes such as: recognizing and valuing unpaid care (OXFAM); ensuring better opportunities for young mothers (SIDA); and digital literacy for women (UNDP and SIDA). Many organizations state they engage with men and boys (which is recognised way to improve efforts to address gender equality concerns, rather than focus on women alone)⁷¹. IFAD has been at the forefront of implementing HHM, and together with the other RBAs, it has contributed to the conceptualization of Gender-Transformative Approaches (GTA) and Gender-Transformative Programming (GT programming).
62. **Compared to other agencies, IFAD lacks a comprehensive online gender toolkit encompassing all facets of IFAD's GEWE efforts, accessible to people who work in operations.** FAO developed a consolidated GEWE handbook for gender focal points⁷². Other organizations have consolidated the key information about GEWE in a stand-alone repository or 'one-stop shop', like [Sida](#), [CGAC](#) and WFP (only available for internal staff). While IFAD's guidance, tools, and publications on gender equality are in line with the broader efforts of UN agencies to promote GEWE, IFAD does not yet have a consolidated online gender toolkit encompassing key information about IFAD GEWE's approach. The available toolkit concerns poverty targeting, gender equality and empowerment during project design and during implementation (June 2017), which has been complemented with other resources, which are not entirely coherent.
63. **Results-based reporting on GEWE continues to be a challenge for many organizations, but some comparator organizations are reporting at the outcome level.** Most comparator organizations (AfDB, Oxfam, UNDP, CARE) report on the number of women reached accessing key services,⁷³ and others report inputs, such as financial resources spent on gender and channelled through specific partners.⁷⁴ CARE and UNDP report figures similar to IFAD's gender policy objectives 1 and 2⁷⁵. IFAD does not report at the corporate level on contributions towards its three strategic objectives.

D. Relevance of promotion of GEWE in IFAD's interventions

a. Quality of gender information included in COSOPs and PDRs

64. There is an increased focus on GEWE in more recent COSOPs compared to older ones, but still scope for more mainstreaming of gender concerns. IFAD has been reporting since 2013 that all COSOPs have mainstreamed gender. The TE analysis of 19 COSOPs across the eleven country case studies showed that COSOPs from 2019 onwards included greater attention to GEWE issues, for example, **Sudan, Tunisia, Cameroon, and Kenya**. Some specifically mention the use of GTA such as GALS or targeted training for women. **Türkiye's** COSOP stressed the need for positive discrimination in targeting female beneficiaries. The TE analysis of 25

⁷¹ UN Women, 2020 suggests **working on men's and boys' attitudes towards GE**, spanning sexual and reproduction health, parenting and violence prevention. However, some argue that reporting on efforts to work with men/boys often highlight individual-level changes and there is lack of consistent evidence of change in power dynamics.

⁷² <https://www.fao.org/3/cb2401en/CB2401EN.pdf>

⁷³ For instance, access to basic services, financial and non-financial services (UNDP), women-headed households accessing clean energy (UNDP), benefit from investee project or improvements in agriculture (AfDB).

⁷⁴ Ex. through women's rights movements (SIDA, GAC); or through women-led community organizations (UNDP).

⁷⁵ UNDP reports on the number of partners that support organizations to advance women's leadership and number of countries with measures to advance women's leadership, and CARE reports on women with greater voice and leadership in their projects and on control over economic resources.

COSOPs (approved after 2016) found that in 18 COSOPs rural women were characterised as vulnerable rather than also as critical agents of change. There was however mention of the need for better integration of women and marginalized groups in decision-making at all levels to enhance GEWE outcomes.⁷⁶ COSOPs typically referenced other vulnerable groups (young people, Indigenous Peoples, and persons with disabilities), but did not propose disaggregating data on them by sex nor addressing the differentiated gender-related problems they faced⁷⁷.

65. **Some COSOPs are not well aligned with gender-related national frameworks.** Less than half of the 25 COSOPs referenced national gender policies/strategies or established linkages with them in terms of policy coherence with IFAD's work.⁷⁸ Some COSOPs highlighted that countries lacked a gender policy or strategy, or their existing policies were outdated (**Georgia, Tajikistan, Uganda, Peru**). Others noted that certain countries have sectorial gender strategies applied to agriculture (e.g., **Mozambique, Ethiopia and Rwanda**). Only two of the 25 COSOPs reviewed (**Bangladesh and Rwanda**) highlighted national laws that discriminate against women and propose ideas of how to contribute to address them, at least partially⁷⁹.
66. **Regional gender analyses have been produced at IFAD to inform COSOP and PDR gender strategies but remain a work in progress.** In 2013-2014 and 2019-2020, regional briefs on key gender and social inclusion issues were developed to inform upcoming COSOPs and PDRs. However, according to interviews, their utility was not proven, and they have been discontinued as they were not considered actionable enough. The future alternative is to test socioeconomic assessments (covering all mainstreaming themes) in ten countries where a COSOP will soon be prepared although further information was not available when finalizing the TE report.
67. **The interlinkages between gender and climate changes are not fully considered in COSOPs.** The case studies undertaken for the IOE TE CCA in 2020-2021 show that COSOPs infrequently integrate both climate change and gender, although many mention how women rural women may be more vulnerable to climate change. Some exceptions were noted – **Sudan's** COSOP, which references gender related lessons to scale up from earlier projects. Other COSOPs mention gender but do not explicitly link gender to climate change⁸⁰.
68. **Some IFAD-supported projects took into consideration women's vulnerabilities and specific needs in climate analyses.** The 2021 IOE CCA TE found some good practices,⁸¹ while others, such as various project designs in **Ethiopia** and **Burundi** PIPARV-B were not informed by gender analyses and did not have information on the integration in project implementation. The absence of such thorough assessments meant that targeting was not fine-tuned in terms of women's vulnerability to climate change nor their agency to adapt. IFAD's

⁷⁶ The extent to which representatives of rural women and men are consulted during COSOP formulation is unclear. Most COSOPs report that they have broadly involved target beneficiaries during the preparation process sometimes via surveys or focus group discussions or with representatives of producer organizations, or other organizations.

⁷⁷ This was also noted in the recent IOE ESN on targeting. The 2023-2028 **Bangladesh** COSOP stands out as an example with a strategy to mainstream gender and commitment to design all projects in consultation with target groups, including women. See more detailed findings from the analysis of the COSOPs in Annex IV.

⁷⁸ **Colombia, Eswatini, Ivory Coast, Ethiopia, Guinea, Lao PDR, Mozambique, Nigeria, Peru, Senegal and Togo.**

⁷⁹ In **Côte d'Ivoire** and the **Dominican Republic**, the COSOP strategic objectives support the implementation of land tenure laws, policies on access to financial services, and the participation of women in dialogue and decision-making.

⁸⁰ For example, the **Rwanda** COSOP mentions women's social and economic inclusion, and the **Ethiopia** COSOP aligns with the Ministry of Agriculture gender mainstreaming strategy but does not mention climate change. See additional findings on the climate-gender analysis in Annex IV.

⁸¹ For instance, the participatory preparation of adaptation plans used in **Nepal** ASHA and **Sudan** LMRP allowed space to incorporate the needs and challenges of targeted rural communities, including specific vulnerabilities of women. The PRO-LENCA project in **Honduras** integrated climate considerations through a collaborative community driven process with a focus on gender to identify needs. However, according to the recent IOE sub-regional evaluation in the *Corredor Seco*, difficulties were faced during project implementation, creating discontent among indigenous communities, despite several negotiations.

management report ([2022 ASAP report on Climate Change and Gender](#)) also found that most projects did not link gender or targeting strategies with adaptation, which could result in exacerbating existing gender gaps.

69. **Since GEWE has been integrated with the other IFAD mainstreaming themes in investment projects, the GEWE relevance and focus can become watered down under compliance procedures and overstretched staff.** A high proportion of the 47 GT-validated projects include the validation for other mainstreaming themes compared to projects not rated as such.⁸² The TE also confirmed the finding of the ESN on Targeting (2022) that there is a misconception that projects must address all mainstreaming themes, rather than identify the critical themes. IFAD also started to include youth, nutrition and other themes in GTAs such as GALS, while previously it was only focused on gender inequality issues.⁸³ The TE did not locate substantive efforts within IFAD operations to focus on specific gender approaches for indigenous men and women⁸⁴. While the staff and consultants from the social inclusion cluster are expected to address all these themes, interviews suggest this expectation is not always met (see section VI.E).
70. **The quality of gender strategies in project designs continues to be variable, unaided by IFAD's efforts to streamline the project design process since 2018.** Various past ARRIs (2015, 2016, 2018) identified weak gender strategies in project designs as a recurrent issue affecting performance. More recent analyses by IOE and commissioned by Management show that the quality of gender strategies remains variable.⁸⁵ Despite the intention to streamline the PDR template, there is now a lack of clarity of where gender and social inclusion related text 'belongs'. References to social inclusion are mainstreamed throughout the PDR, but the approach lacks coherence. Sometimes social inclusion overshadows the attention to addressing gender inequalities. In other cases, the project economic analysis or climate information in the SECAP receive lengthy attention, while detailed information about the people at the heart of a project is minimal. The IOE CLE on decentralization highlighted how many ongoing reforms and changes affected the operational cycles in country offices. This is further analysed in Section VI.
71. The removal of the PDR annex II on poverty, targeting and gender after 2018 reduced the depth and breadth of social assessments intended to inform people-centred development projects. It was replaced by the social component of the SECAP, which is often limited in content. TE interviewees confirmed this. The former use of targeting and gender checklists in annex II, which ensured coverage of both programmatic and operational aspects in gender strategies, was scrapped. Occasionally design teams still revert to the structure of the old annex II, including the use of targeting and gender checklists thus making them comprehensive on both programmatic and operational aspects of design.⁸⁶ Examples of when the gender content is of good quality in the SECAP are available.⁸⁷

⁸² In fact, 85% of GT projects are also rated as Youth Sensitive, 68% rated Nutrition Sensitive and 94% are validated as Climate Finance projects. On the other hand, 75% of projects not rated as GT are Youth Sensitive, 52% are Nutrition Sensitive and 84% are also Climate Finance projects.

⁸³ For instance, in **Uganda**, household mentoring and GALS were integrated with food security grants; in **Madagascar** and **Rwanda**, GALS was funded by climate ASAP grants to improve adaptation capacity since 2022.

⁸⁴ The activities of the IFAD Indigenous Peoples Assistance Facility were not assessed.

⁸⁵ Findings draw on a 2022 internal analytical review of 28 PDR (classified as GT) since 2019, the IOE 2023 ESN on targeting in IFAD-supported projects, the TE e-survey, and field mission interviews.

⁸⁶ **Programmatic aspects** include gender analysis, targets for women's engagement, gender strategy, GEWE pathways of change in TOC, policy engagement. **Operational aspects** include training, M&E, budget, risks and exit strategy.

⁸⁷ Value chains for Inclusive Transformation of Agriculture, **Nepal**; Livestock Commercialization Project, **Kenya**; Small Scale Aquaculture Promotion Project, **Mozambique**; Smallholder Agriculture Cluster Project, **Zimbabwe**; Promotion of Resilient and Sustainable Food Systems for Family Farming, **Argentina**; Planting Climate Resilience in Rural Communities of the Northeast Project, **Brazil**; Project to Improve Productivity and Access to Markets of Agricultural products in Savannah Zones, **Central African Republic**

72. Many operational staff find it difficult to adapt project gender strategies to the priorities of different groups of men and women in various implementation contexts. The TE e-survey showed that this was the case for 55 percent of PMD staff and consultants (with more male respondents agreeing than females). Potential causes of this perception, were also identified by the IOE ESN on targeting, are explained below.

Box 10

Identified weaknesses in new project designs.

Opportunities to base targeting decisions on listening to poor people to identify priorities and collaborating to generate solutions have reduced. Reviews of ESN case studies show that the practice is declining in new project designs (approved in 2021) where only one out of the 10 reviewed had done so.

A number of new project designs reviewed indicated that detailed analyses will be undertaken at baseline or during early implementation, which is at odds with IFAD's guidance. This means that PDRs do not provide the needed clarity on the target groups nor differentiated pathways of change.

Source: IOE 2023 ESN on targeting in IFAD-supported projects

73. **b. Relevance and challenges of gender approaches in COSOPs and projects In COSOPs and PDRs, the inclusion of quotas in the targeting strategy is often the sole information presented as the proposed "gender approach".**⁸⁸ Quotas are typically put in place to ensure that vulnerable segments of society, including women and girls, youth, and people with disabilities, form part of the target group. Eight out of 25 COSOPs advocate for the use of a gender quota system.⁸⁹ Most (68%) of the 522 PMU respondents to the TE e-survey consider male/female quotas for participation in project activities are sufficient in assessing GEWE performance, while this percentage is lower (45%) among the 166 IFAD PMD staff and consultants⁹⁰. However, two thirds (66% for PMU and 63% for PMD) indicated it is feasible to measure access to goods and services by rural men and women (or the actual "benefits" derived or the improvement in their well-being).⁹¹
74. The TE GEWE found that whilst the use of the quota system is an important step to ensure the inclusion of women in IFAD interventions, it requires an understanding of existing ratios of different groups prior to setting targets as well as an analysis of gender roles in different types of farming systems. Information about how to promote or enforce quotas in various types of activities is not usually found in IFAD COSOPs or PDRs. The country case studies identified various implicit strategies to reach female/male quotas for different GEWE practices (see below).

Box 11

Strategies identified to reach quotas for rural women (and men) in IFAD project investments.

- Include a percentage of women in members of the producers' groups (or their management committees) as an eligibility criterion (all case study countries);
- Use implementing partners that work with large numbers of women, e.g., microfinance institutions (**Ethiopia**), or women-only microfinance initiatives (Absumi in **Sudan**);

⁸⁸ Other COSOP or PDR just mention the combination of GEWE practices proposed, only in few cases, there is a clear linkage with the specific gender gaps in the country or in the projects/programmes implementation areas.

⁸⁹ For example, the COSOP for **Eswatini** has defined a 40% quota for the participation of women, 40% for youth and 8% for persons with disabilities. For **Guinea**, included a 30% quota for women and youth representation in decision-making bodies. Other examples are found in COSOPs of **Kyrgyzstan**, **Moldova**, **Rwanda**, and **Togo**.

⁹⁰ Some contributions on this matter: "M/F participation quotas give a quantitative indication but do not reflect the quality of women's activities compared to men's" (Male PMD staff/consultant, WCA, more than 10 years of experience at IFAD); "It is much easy to assess women participation in terms of quantitative data, however, we still face the challenge of qualitative information on women empowerment." (Female PMU staff, ESA, 2 to 4 years of experience at IFAD).

⁹¹ The "reach-benefit-empower" framework (Johnson et al., 2018) was devised to help planners distinguish between levels of empowerment strategies and their measurement. Kleiber et al. (2019) added "transform" to the framework to address interventions aiming to transform discriminatory social institutions and unequal power relations.

- Support value chains or productive activities that have a high concentration of women (**Cambodia, Argentina, Sudan, Türkiye**);
- Offer preferential conditions for women (ex. **Tunisia, Argentina, Honduras**⁹²) or adapt project activities to constraints identified by women (**Cameroon, Sudan, Tunisia**);⁹³
- Use females as local services providers to ensure women participation where social norms prevent them interacting with men outside their family (**Türkiye, Sudan** and **Tunisia**).

Source: TE country case studies.

75. **The justification for female targets, or subgroups, is not always clearly included in IFAD design documents.** Certain country case studies pointed out the overestimation of targets for women in PDRs (**Cambodia, Mauritania**). In other instances, project implementing partners did not consistently adhere to the IFAD target group criteria. For example, the IOE project-cluster evaluation on rural finance revealed that IFAD's rural finance project (RUFIP II) in **Ethiopia** utilised microfinance institutions and RUSACCOs to choose beneficiaries for its credit line component. The project did not sufficiently influence nor monitor the extent to which poorest women were being reached by financial services⁹⁴. Various mechanisms identified to target women are summarized below.

Box 12

Strategies to directly target rural women in IFAD project investments.

- Specific activities for women, such as small-scale businesses and micro projects (seven of the 23 IOE evaluations, and six of the TE country case studies);
- Target mixed producers' groups that already have significant number of women (**Kenya**⁹⁵, **Cambodia, Sudan, Mauritania, India**);
- Projects with 100% of women as participants (**India** Tejaswini project 2005-2018)
- Implementation of "affirmative actions" specifically targeting women, youth and Indigenous Peoples (**El Salvador, Argentina**);
- Only-women financing windows (**Argentina** PROCANOR through *En Nuestras Manos*) targeting only-women producer groups and victims of gender-based violence.
- Household methodologies which target women as integral in family business and decision making (many countries).

Source: TE country case studies ad synthesis of 23 IOE evaluations.

76. **Although IFAD projects identify different categories of rural women, tailored approaches to reach them are not always developed.** Rural women are not a homogenous group. Sometimes, the national gender diagnoses and strategies mention women subgroups which have higher levels of vulnerability rather than catalysts for transformation. The IOE 2017 evaluation synthesis on gender recommended the need to develop explicit theories of change to underpin targeting strategies for different groups of women⁹⁶. Management agreed with this

⁹² **Tunisia** projects offered preferential conditions to young women to access family poultry and dairy goat income-generating activities (IGAs); **Honduras** EMPRENDESUR received a higher price fair trade and organic-certified coffee.

⁹³ Through PEAJ (**Cameroon**), babysitters were recruited, and special arrangements made for young mothers to ensure their full participation to the intensive training in incubation; **Tunisia**: Considering women's constraints in relation to transportation, schedules with other family responsibilities; **Sudan**: Transfer all training to the village level as in some areas, women cannot travel outside their villages. If a nominated woman cannot attend a meeting for some reason, another woman should replace her, even if she must come from another village.

⁹⁴ This PCE finding extends to other rural finance projects, **Kenya** PROFIT and **Zambia** RUFEP.

⁹⁵ During field visits in **Kenya**, interviewees noted more women-only groups in regions where IFAD operates. Additionally, some men reported that joining groups supported by IFAD projects has assisted in alleviating loneliness and isolation, especially among older individuals.

⁹⁶ The 2018 ARRI reiterated the need to base targeting strategies on robust poverty analysis and differentiated context analysis to meet the needs of different target groups (such as women and youth).

recommendation, but the ESN on targeting and the TE have not found consistent efforts in this direction.

77. **The TE confirms the finding in the ESN on targeting that IFAD projects usually assume female-headed households are more vulnerable or poorer, without providing more data.** Female-headed households are a common sub-group targeted by IFAD interventions.⁹⁷ In some instances, IFAD interventions justify this choice because of projects being located in areas with high rates of rural male migration (**Sudan** IAMDP and **Mexico** PROINPRO). Recent PDRs highlight additional dimensions of vulnerability that impact women, but did not include clear differentiated intervention strategies⁹⁸. However, some GT-validated PDRs still treat women as a generic group or include generic statements about youth and gender (**Cameroon** PADFA II, **Morocco** PRODER-Taza and **China** H2RDP). Some projects analysed for the IOE TE on CCA also raised the importance of targeting women in particular situations or sectors (e.g., landless women, women in non-agricultural enterprises)⁹⁹.
78. **Early experience of ongoing non-sovereign operations supported by IFAD shows the potential of mobilizing private sector resources and know-how to reach more rural men and women.**¹⁰⁰ IFAD's first non-sovereign operations (NSO) in Northern Nigeria is using family referrals as a targeting strategy. In 2020, IFAD started supporting the franchising model for maize and rice and the Women Economic Development Initiative (WEDI) of Babban Gona (BG) Farmer Services Nigeria Limited. The IFAD investment proposal aimed at generating 65,000 jobs for women as smallholder farmers, entrepreneurs or employees by 2025. This target has already been more than doubled, according to self-reported data, see below.

Box 13

Applying IFAD gender requirements in a non-sovereign operation in Nigeria

BG developed a **Women Economic Development Initiative (WEDI)** where existing BG farmer members recommend female relatives who are then supported with in-kind credit, training and inputs to become entrepreneurs in businesses (e.g., in **poultry farming**). By 2022, more than 18,500 women entrepreneurs were supported (ranging from small-scale backyard poultry/retailer to more commercial-oriented activity) and 115,000 women received financial and business management vocational training.

In addition, targeting of farmers in BG maize and rice programme occurs through **farmer referrals** as well as **field visits by BG staff**. The SECAP note accompanying the IFAD investment proposal included restricted tenure security and access to **land by women** as limiting factor for their involvement in the maize and rice value chain. In 2022, BG piloted a **land lease programme** which linked BG members with more land than they could cultivate with 256 farmers without land (6% of them women younger than 40 y.o). BG staff interviewed reported the willingness of the company to expand this modality. Despite these efforts, the total female farmer members in the maize programme are only 22,252; below the aspirational target mentioned in the text of the investment proposal (21% of the targeted smallholder farmers).

Source: Desk review and interviews with key actors.¹⁰¹

⁹⁷ In **Nepal** and **Indonesia** CSPEs, nearly all projects incorporated women-headed households into their targeting strategies, as project-level evaluations in **Vietnam** CPRP, **Sao Tome-Principe** PAPAC, and **Uruguay** PPIR. In **Sudan's** LRMP, women-headed households were further categorized into sub-groups such as widows, polygamous households, and households where men have temporarily left. Various recent PDRs also included this subgroup of women (**Zimbabwe** SACP, **Kenya** KelCOP, **Cambodia** ASPIRE-AT; **Sri Lanka** SARP, **South Sudan** SSLRP).

⁹⁸ For example, the TE GEWE found PDRs with a specific focus: on young women (**Argentina** PROSAF, **Kenya** KelCOP, and **Mali** FIER); women with disabilities (**Cambodia** ASPIRE-AT, **Mali** FIER); indigenous women (**Argentina** PROSAF, **Brazil** PAGES); and migrant or returnee women (**Argentina** PROSAF, **Sudan** SSLRP).

⁹⁹ For instance, **Bolivia** ACCESOS targeted women interested in non-agricultural enterprises because their ability to diversify their livelihoods and build resilience.

¹⁰⁰ The TE refers to the definition of "private sector" in IFAD Private Sector Engagement Strategy 2019-2024.

¹⁰¹ 2022 Annual report. Babban Gona, better your life; 2020 Investment proposal (+ SECAP note, annex 5).

79. Another ongoing private-sector operation in Madagascar set a quota of rural women to be associated in contract farming. IFAD is supporting a medium-sized agri-aggregator company (SOAFIARY) through a non-sovereign operation approved in 2021. IFAD provides technical expertise and a loan to expand the acquisition of grains and legumes from smallholder farmers (SHF). The company was founded and is led by a woman, and women represent the majority of SOAFIARY's senior management and employees. This project is expected to increase the revenue of 4000 SHFs and provide technical assistance and inputs to 2000 SHF by 2025, of whom 35% women. According to the investment proposal, the targeting strategy seeks to select farmers struggling from the impact of COVID-19, but with a reasonable amount of land, who are already established and harvesting. It also states that SOAFIARY has requested partner farmer groups to hire landless women and youth groups to engage in ancillary activities. According to the 2023 supervision report, 220 women have been linked to the company so far (22% of the total SHF reached), 131 women received technical assistance and 66 agricultural inputs.

Key points about the Relevance and coherence of IFAD support to GEWE (Section III)

- **IFAD's Gender Policy** remains relevant to the SDGs and aligns with global strategies for gender equality. While IFAD contributes to some targets and indicators of SDG 5, others receive less attention.
- Although IFAD's Gender Policy broadly aligns with corporate priorities, **some practices, issues and themes are missing or not fully incorporated**, such as gender-transformative approaches and intersectionality (as outlined in the new IFAD Targeting Policy).
- IFAD does not have a **comprehensive and field-friendly gender toolkit** including guidance on results-based reporting on both quantitative and qualitative GEWE outcomes, and how to report on IFAD's contributions to policy outcomes that affect GEWE.
- IFAD underlines the importance of a workload balance focus. The other gender strategic objectives (economic empowerment and decision-making/ representation) are common across **comparative organizations**.
- More recent **COSOPs** demonstrate an **increased emphasis on GEWE**, although there is still room for improvement. Many still characterize rural women primarily as vulnerable rather than recognizing their potential as agents of change. Few COSOPs reference **national laws** discriminating against women nor propose ways to address them.
- The quality and coherence of gender strategies in **project designs** remains variable. The integration of gender equality within IFAD's work faces challenges such as dilution under SECAP compliance procedures and a lack of time to focus on the best strategies due to over-stretched staff capacities.
- **IFAD's non-sovereign operations** show potential for innovative targeting of rural men and women through private-sector partnerships.

IV. IFAD's contribution to GEWE performance

80. This section begins by presenting the TE assessment of the GEWE performance since the approval of the gender policy, using the available gender ratings of independently evaluated project investments. The limitations regarding the available outcome data in supervision and completion reports (self-evaluations) are outlined. The aggregated findings of the contribution of GEWE practices used in IFAD interventions (COSOPs, investment projects and grants) to the three strategic objectives of the gender policy are subsequently presented. The practices which tried to address the root causes of gender inequality and contributed to transformative results are examined and presented along with the factors affecting GEWE performance at IFAD. Section IV finishes by presenting the results of the TE assessment of recent efforts to mainstreaming gender transformative approaches in IFAD investment projects (Gender Transformative programming). Evidence used in Section IV comes from a trend analysis of project gender ratings, 11 country case studies, synthesis of 23 recent IOE evaluations, qualitative comparative analysis applied to all completed projects since approval of the policy, a desk review of supervision and completion reports, responses to the TE e-survey and an analysis of a sample of GT-validated project designs along with interviews with IFAD and partners.

A. GEWE performance trends of IFAD interventions

81. More than half of the completed and independently evaluated projects (that have been approved since the gender policy) were rated moderately satisfactory or above at completion¹⁰². The majority of the projects approved since 2013 and independently evaluated were rated 4+ for gender by IOE: 44 per cent were rated 4 and 25 per cent were rated 5.¹⁰³ LAC region had the highest proportion of completed projects rated 5+, both by self-evaluation¹⁰⁴ and independent evaluation (see Annex XIII). The TE found a positive correlation between GEWE ratings when compared with the overall project performance ratings in both management and IOE reports. Correlation analysis¹⁰⁵ reveals a statistically significant positive relationship between the two criteria (correlation coefficient of 0.61 when using IOE ratings).
82. **Average GEWE project ratings at completion have displayed a declining trend since 2013.** The disparity between self and independent evaluation narrowed after 2018-2020¹⁰⁶. The comparison of the mean rating between IOE and PCR GEWE ratings is depicted below. In ARRI 2021, GEWE had the highest disconnect among the criteria, ARIE 2022 shows a slight improvement, driven by a lower GEWE rating average from PMD. The 2022 IFAD evaluation manual, covering both self-evaluation by IFAD management and independent evaluation, is anticipated to contribute to closing the gap by fostering a shared understanding of criteria behind the gender marker/ratings.

¹⁰² Out of 263 investment projects approved in 2013-2022 (and not cancelled/suspended), 34 projects are completed and 28 out of these 34 projects have been also evaluated independently by IOE (completion year from 2018 to 2022), either through a validation of the PCR or through a Project Evaluation.

¹⁰³ The PMD self-evaluation ratings (PCR) are slightly higher: 53% were rated 4 and 33% were rated 5.

¹⁰⁴ Completed projects rated 5+ is the only gender indicator which is not met in the last RIME (2023). The target is 60 per cent of completed projects making a substantial contribution to gender equality (rated 5+), while the IFAD's rolling-average (2020-2022) stands at 42 per cent.

¹⁰⁵ Spearman's rank-order correlation is used to observe possible two-way relationship between two ordinal variables.

¹⁰⁶ The analysis of GEWE performance at completion was expanded to projects completed after the IFAD gender policy (end of 2012). There are 318 projects completed from January 2013 to 31 December 2022. A subset of 250 have PCR and IOE GEWE rating. IOE used the ARIE Methodology based on the completion year, using data from the IFAD system as of February 2023. RIDE reports use the closing year, potentially resulting in variations in percentages of projects compared to this analysis.

Figure 4
Average IOE and PCR GEWE ratings by three-year moving period

For projects completed in 2013-2022 with both IOE and PCR GEWE ratings available (N=250).

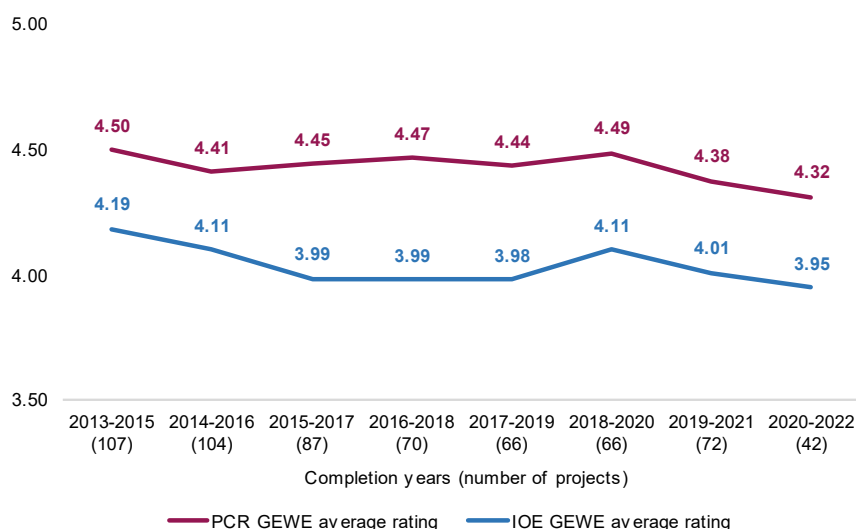

Source: TE team, based on IFAD ORMS completion database and IOE database (accessed in February 2023).

83. The GEWE performance trend reported in IOE ARRIs improved during the first years of the evaluation period, it then started to decline, only improving in the most recent ARRIs. At the beginning of the period (ARRI 2013-2016), GEWE performance demonstrated a consistent improvement with the proportion of projects rated moderately satisfactory or higher (4+) increasing from 74% to 91%. Following its peak in ARRI 2016 (2012-2014), GEWE performance has steadily declined, with only a slightly improvement noted in ARRI 2021 and ARIE 2022 (76%)¹⁰⁷. The proportion of projects rated satisfactory or higher (5+) has also witnessed a decline since ARRI 2017. More information about the GEWE analysis included in ARRIs since 2013 is included in Annex XIII. The next section delves into the use of GEWE practices in IFAD investments and how they contribute to the three strategic objectives.
84. **Project M&E, supervision and completion data show serious weaknesses in assessing performance of gender.**¹⁰⁸ The TE desk review found that most of the reported data in IFAD about gender is concentrated in “**reaching** indicators”, such as including women participants in project activities. Only in a few cases, there was evidence about **benefits** (about how project activities contributed to improve women’s circumstances or to close specific gender gaps identified during design/base line). Similarly, the TE desk review found that there was only anecdotal information about how participating in certain project activities could have contributed to **women’s empowerment**. The IFAD11 Impact Assessment in 2022 measured women’s empowerment through the impact assessment of 24 projects which closed during IFAD 11 (2019-2021). Only 10 of the 24 projects in the sample were approved after the IFAD gender policy. According to this source, women in beneficiary households have 27 per cent more decision-making power than women in comparison households. However, impact on asset ownership indicators was found negligible and not statistically significant from the control

¹⁰⁷ This analysis relies on the IOE ARRI from 2013 to 2021, and the renamed ARIE in 2022. The ARRI/ARIE reports utilize cohort analysis based on a three-year-rolling period by project completion. There is a 2-year reporting lag, meaning the latest projects are completed 2 years before the ARRI year. The recent cohort in the ARRI 2021 analysis comprises projects completed in 2017-2019. Although the numbers may differ, the overall assessment of GEWE performance over time aligns with data from the latest IOE rating database, last updated in February 2022.

¹⁰⁸ The [CGIAR Reach-Benefit-Empower framework](#) was adapted to guide the analysis: **reach** (how men and women are included in project activities), **benefit** (how activities improve men and women’s circumstances), **empower** (how project activities contribute to strengthening men’s and women’s ability to make and put into action strategic life choices).

group. This source considers impact on asset accumulation is a long-term process.¹⁰⁹

85. **The TE identified several factors contributing to the general weak gender outcome reporting in self-evaluations, despite of availability of guidance at IFAD to monitor data from a gender perspective during implementation.**¹¹⁰

The TE identified as factors explaining the weak quality of gender outcome data the inconsistent inclusion of an IFAD gender experts in field missions during the evaluation period and the perception of many IFAD and PMU staff that reporting male/female numbers and reaching quotas in project activities are sufficient in assessing GEWE performance. More information and examples are provided in Annex XIV.

86. Most of TE e-survey respondents agreed that the IFAD gender marker is applied systematically across the project cycle.¹¹¹ However, the TE's review of the gender sections of supervision/implementation support of projects in country case studies¹¹² found that, in most of cases, the justification of gender ratings is based on: outreach metrics (percentage of female participants¹¹³), the (timely) development of the gender project strategy/action plan, or the appointment of Gender Staff within the PMU. The importance of monitoring these programmatic and operational aspects is acknowledged by the TE, but the system itself does not provide information on progress towards GEWE outcomes or challenges faced and guidance to solve them. This was also highlighted in some of the project supervision reports reviewed.¹¹⁴

87. The next section delves into the evidence available on the contribution of IFAD interventions (COSOPs, project investments and grants) to GEWE, firstly to the three strategic gender policy objectives, then, analysing those which made serious attempts to contribute to transformative changes, albeit at limited scale.

B. Contribution of IFAD interventions to GEWE performance

a. Contribution to the three strategic objectives of the gender policy

88. Due to weak reporting on GEWE results, the TE examined the inclusion and implementation of GEWE practices in IFAD interventions (COSOP, project investments and grants) as a proxy to assess their contribution to the IFAD's three gender policy objectives. **GEWE practices** are combinations of activities usually funded by IFAD investment projects that, in various combinations, can contribute in some way to gender equality and women empowerment. The list of GEWE practices, organized around the three IFAD policy objectives, was developed based on the typology that emerged from the IOE 2017 gender synthesis of 57 evaluation reports. This was further refined through consultation with IFAD gender staff and incorporated into the TE's theory of change¹¹⁵. The GEWE practices can be found in the Evaluation Theory of Change (Figure in Annex III). Annex XV offers additional

¹⁰⁹ Women's increased decision-making power is defined in these IA as women's ability to decide on the use of resources either solely or jointly with men; women's increased ownership of assets refers to livestock, land and other assets. Proxies of these two dimensions were used in each of the IAs.

¹¹⁰ IFAD published in 2017 a [How to do Note on poverty, targeting and GEWE during project implementation](#). Annexes 5 and 6 provide key information to assess gender performance during implementation.

¹¹¹ 68% of PMD and 80% of the PMU staff said they had a good understanding of the gender marker. However, 22% of PMD staff and consultants responded "I don't know". Some regional divisions have a peer review system which, according to interviews, improved the understanding of IFAD and PMU staff of the difference between ratings.

¹¹² The TE reviewed the SVPs and mid-term reviews of projects during the evaluation period for: **Cambodia, Cameroon, Ethiopia, El Salvador, Sudan, Tunisia and Türkiye**. Some SVPs were also analysed for **Kenya and Argentina**.

¹¹³ Subcategories within the targeted population, such as youth or indigenous peoples, frequently lack disaggregation by sex. In many instances, the focus on reaching women becomes overshadowed within a broader category of 'vulnerable individuals', sometimes, due to the lack of sex-disaggregated poverty data.

¹¹⁴ Various supervision reports of projects in **Ethiopia, Türkiye, India and Tunisia** recommend the improvement of M&E systems to capture gender outcomes more effectively.

¹¹⁵ Beyond this set of practices, the evaluation acknowledges the importance of adapting project activities to increase participation for various types of end users, including rural women. For instance, ensuring the timing of meetings and trainings is easy to combine with domestic chores or childcare, or does not collide with mobility barriers.

information on the specific countries/projects where practices were observed during field visits. It also contains information on the 23 recent IOE evaluations synthesized in this TE along with the 29 projects completed since the approval of the gender policy.

89. **Economic empowerment (the first IFAD gender policy objective) was used successfully as an entry point for GEWE in many IFAD interventions, including in contexts with high gender inequality.** All analyses conducted for the TE confirmed that economic empowerment activities/practices are the most predominant GEWE practices in IFAD investment projects. Inclusive rural finance, connecting rural women and men to pro-poor value chains and providing technical/vocational training are the most prevalent subtypes of practices.¹¹⁶ Rural women's financial independence was mentioned by various interviewees as a good starting point to support empowerment. For instance, rather than discussing empowerment per se, grants used income generation as an entry point to reach rural women in 'conservative' locations (with higher gender inequality).¹¹⁷
90. **Enhancing the access to financial services for rural women was linked to economic empowerment (SO1), albeit demonstrating mixed results depending on the context.** Supporting village credit and savings structures and the development of business plans for men and women in producers' organizations were found to be good strategies to facilitate access to financial resources for rural men and women in most countries. However, various evaluations found rural women experienced pervasive constraints regarding financial inclusion of rural women, such as the need to persuade their husbands to use their land as collateral for obtaining loans (See Annex XV).
91. **Supporting rural women to transition from subsistence to commercial farming is not always accompanied by detailed analysis of their needs throughout value chains.**¹¹⁸ Project supervision and completion reports often only report the high participation of women in certain parts of the supported value chains. In some cases, IFAD projects funded studies to identify gender gaps in value chains; in others identified and prioritized value chains showing higher gender gaps/issues. Value chain support by IFAD is often accompanied by technical/vocational training to enhance economic opportunities, which has been also supported by gender grants¹¹⁹.
92. **Support provided for small-scale activities for rural women to generate additional income is linked to enhancing women's standing within their communities as well as better family nutrition.** For instance, backyard gardens and small off-farm activities are typically used for minor family-related expenses and to improve the diversity of food consumed by the family, as noted in seven of the 23 evaluations reviewed and in six country case studies. They do not challenge the constraints faced by some rural women in accessing assets for larger-scale production but accommodate to their care-giving responsibilities¹²⁰. The potential additional burden that rural women may experience is seldom analysed.
93. **Supporting rural women to fully participate in private and public governance institutions (SO2) is useful, but self-reporting does not**

¹¹⁶ Present in more than 60% of the 29 completed projects and 46 projects in the eleven country studies. With lower percentages, they are part of the most common GEWE practices reported in the IOE evaluation synthesis in 2017 and the one conducted by the TE (total of 80 evaluation reports).

¹¹⁷ For instance, this was used in IFAD grants in the mountainous regions of **Tajikistan** and **Kyrgyzstan**), as well as to reach women in non-traditional value chains (red meat value chain in **Zimbabwe** and **Malawi**).

¹¹⁸ This was identified in seven case studies. The IOE CLE on value chains highlighted that gender needs to be considered at design through detailed analysis of the different needs of rural men and women.

¹¹⁹ Most of the activities included in the gender grants analysed were focused on capacity development, ranging from business, financial (such as electronic wallets) and organizational training.

¹²⁰ For instance, IFAD projects promote activities that require less land or less time (such as aquaculture or small poultry rearing in **Kenya** or aquaculture in **Cameroon**), as adapted to their reproductive roles and high workloads.

capture their real power in decision-making. Turning to IFAD second gender policy objective, enforcing quotas for women in the management committees of producers' organizations is a common practice in IFAD's portfolio. However, the reported figures sometimes conflate the representation of women as members of the producers' organizations with their participation in the decision-making committees. Moreover, the specific role of women in the committees is often not detailed in reports. Field visits found that women typically assume administrative roles. Similarly, some IFAD interventions (in)directly support rural women to participate or take certain positions in local governance institutions such as village development planning committees or local councils, or in self-help groups. Indeed, self-evaluation reports usually praise these cases, when they happen, without analysing if this participation is symbolic or has any effects on GEWE (See Annex XV for examples).

94. **The results linked to *Cerrando Brecha* ("Closing the gap") to intentionally close gender gaps within rural producers' organizations are not systematically reported in IFAD documents.** The evidence found about the use of this practice in El Salvador projects, where it has been more widely used, shows limited outreach numbers and lacks analysis of the outcomes of the rural producers' organizations where it was applied. Self-evaluation reports intertwine *Cerrando Brecha's* activities with other project activities targeting rural women, youth and Indigenous Peoples (See Annex XV for details).
95. **Funding time- or labor-saving infrastructure and equipment is often portrayed as a way to address gender inequality in relation to workloads (SO3).** Examining the third gender policy objective, IFAD-supported projects commonly include practices to reduce the drudgery of tasks typically performed by rural women (and children)¹²¹. Water infrastructure (mainly irrigation and water wells/pumps), more efficient cooking stoves and machinery for productive tasks are frequently reported as a way to allow women to engage in economic activities¹²² or to rest and engage in social interaction. Other examples are included in Annex XV. In **Cambodia**, efforts to pilot renewable energy technologies for egg-hatching and brooding were both useful for environmental purposes and for improving their rest overnight¹²³. Very few IFAD projects included provisions to facilitate the participation of women with caregiving responsibilities. Field visits and interviews revealed that PEA-J in **Cameroon** facilitated the participation of young mothers in intensive training by providing childcare support, which is also included in IFAD's portfolio in **Brazil**, according to IFAD gender staff interviewed.

b. GEWE practices contributing to open spaces for rural women and men to challenge and change social norms related to gender inequality.

96. IFAD projects have been incorporating GEWE practices contributing to changes at the individual, household and community level which touch on social norms and root causes of gender inequality, with a more systematic effort noted from 2016. Evidence suggests that it is often the combination of a number of practices that contribute to transformative changes, although this is highly context specific. The following subsection summarizes the evidence found through country field visits, desk reviews and interviews. Land and intra-household decision-making are

¹²¹ 62% of the 29 completed projects and most of the projects covered in the TE country case studies. Also, many of the twelve gender grants reviewed included the provision of time-saving tools and technologies to contribute to women's economic empowerment (like bikes, washing machines, stoves, refrigerators).

¹²² However, some interviewees during the field visits raised the point about the significant time required from rural women to attend to certain project activities, asking for more efficient and practice-oriented training sessions.

¹²³ The GEF grant Scaling Up Renewable Energy Technologies (S-RET) managed by IFAD partnered with Khmer Green Charcoal (KGC), a company that supplies "green" charcoal (briquettes produced from coconut shells waste) as an alternative to wood-charcoal. Prior to the project, because of inefficient combustion of wood-charcoal, rural women had to wake up several times in the night to refuel the stove; a challenge that was alleviated by the char-briquettes that had longer burning times.

sometimes reported under SO1 and SO2, respectively. The TE included them here as they challenge social norms in rural settings¹²⁴.

97. **IFAD's interventions do not consistently address land tenure issues, despite its importance as a root cause of gender inequality.** Limited land tenure (or secured access to land and other resources) is among the most pervasive barriers for women to participate in and benefit from projects interventions. This was mentioned in key national gender diagnostics and policies consulted for the country case studies, IFAD COSOPs and PDRs and by some project participants during the country visits. However, IFAD's projects do not directly address this issue, even though in some cases, this challenge is mentioned as part of the sustainability analysis at completion.¹²⁵ Case studies identified some interesting practices (see box below).

Box 14

GEWE practices to promote a more equal access (and control) of land and other natural resources.

Sudan SNRP uses participatory approaches involving women for developing community land use maps which demonstrate a vision for the next 5-10 years. The maps are shared with the wider networks (nearby communities who share the watershed areas).

Argentina: IFAD projects have accepted alternative ways of proving possession/access to land for women such as marriage certificates and municipalities' endorsements.

India CAIM and Nav Tejaswini and **Vietnam** CPRP promoted the registration of joint titles over homestead and farmland. In the tribal areas, the focus was on strengthening women's access to and control over forests and collection of non-timber forest products.

Cameroon PADFA II design proposed to ensure access to women to certain developed plots for rice production, but interviews in July 2023 recognized legal difficulties and mention a grant to work on this with the International Land Coalition.

Land tenure issues are also part of discussions promoted through HHM (especially GALS and Household Mentoring)

A recent **grant** is working on testing ways to secure women's resources rights (land among others) in seven countries through gender transformative approaches.¹²⁶

Source: TE country visits, IOE evaluations synthesis and desk review.

98. **Fostering rural women's leadership and enhancing their functional skills directly tackles some root causes of gender inequality linked to confidence due to an earlier lack of education.** Leadership training targeting women is important in many contexts where IFAD operates. It acts as an enabler for more equitable voice and representation leading to women's economic empowerment, as well as (financial) literacy for women. However, there is limited reported information on the duration, content, and the impact of these types of training programmes.
99. Some practices included in IFAD interventions contribute to promote women's involvement in activities traditionally reserved for men or have improved their 'standing' in the community and in their households. Initiatives such as training and recruitment of women as farmer extensionists, local community or municipality elected officials, have been implemented, as well as encouraging women to take male-dominated rural jobs are some examples (See Annex XV). In addition, IFAD

¹²⁴ This is in line with [CGIAR Reach-Benefit-Empower-Transform framework](#), which also asks for including approaches to **transform gender relations** within and outside the household, such as by changing attitudes in communities.

¹²⁵ The endline survey of PEA-J in **Cameroon** found 45.8% of female beneficiaries stated that their plots remained unsecured after the programme. Discussions with young women in TE focus groups in May 2023 confirmed they used temporary land leases from their relatives, and they worried about losing access to this land if their businesses flourishes.

¹²⁶ **Bangladesh; Ethiopia; Uganda; Colombia; Kyrgyzstan; Niger and Gambia.**

projects in **Brazil** promote that women use agroecological logbooks to document their production, sales and non-commercial exchanges for the community to recognise their often-overlooked contributions to family and agriculture.¹²⁷

100. **Evidence on outcomes from sensitizing and engaging with men in communities as a tool for gender inequality is scant.** Numerous reports emphasize that excluding rural men from gender equality initiatives poses a potential risk of backlash and can undermine the sustainability of GEWE outcomes.¹²⁸ **India** projects sensitizing men to become GE champions is one of the few examples found. General gender sensitization training for project staff and beneficiaries is more common and also important in terms of engaging men and ensuring their support, but its results are not assessed.
101. **The over-reliance of household methodologies as GTAs in IFAD interventions lacked a foundation in evidence regarding results.** The TE examined design and supervision reports of 74 IFAD projects incorporating HHM as of February 2023, and the grants which helped to pilot such approaches. Gender Action Learning System (GALS) stands out as the most prevalent HHM within IFAD's portfolio, predominantly concentrated in East and Southern Africa (See Section II.B). Variations of GALS and other HHM have been integrated into IFAD projects.¹²⁹ During the evaluation period, **Uganda, Malawi** and **Kenya** emerge as countries with the highest number of IFAD projects with HHM.¹³⁰ IFAD has developed guidance and training materials on HHM and has systematized some of the HHM practices.¹³¹ Yet, there is limited information available about the cost, time, and the number of people targeted and effectively reached by HHM activities in the 74 IFAD projects reviewed.¹³²

Box 15

Series of gender grants to test HHMs and bring them to scale.

An earlier grant (before the evaluation period) tried to determine whether HHM makes a difference.

The next grant with a HHM focus focused on **Rwanda, Burundi** and **DRC** to promote the wider use of these methodologies in agricultural extension and value chains.

The third HHM grant, *Scaling up and Empowerment through HHM* (empower@scale) to Oxfam Novib and HIVOS, aimed to ensure more expertise was available on the use of household methodologies in **Nigeria, Kenya** and **Uganda**, and also to focus on disseminating HHM at the regional and global levels.

Source: Desk review and interviews.

102. The inclusion of Household methodologies in IFAD projects is linked in self-evaluation reports as having contributions to the strategic objectives in the gender policy. Sometimes, the inclusion of HHM is a strategy to reach men/women quotas among project participants or specific vulnerable groups among them. Other times it is reported to contribute to joint access and control of large stock animals or women's influence on men's behaviour to rationalize expenditures in favor of the

¹²⁷ This practice/methodology was used in the Paulo Freire Project (2012-2021) with 909 women in 112 municipalities. IFAD. 2021. Analysis of One Year of Use of Agroecological Notebooks in IFAD-supported Projects in **Brazil**.

¹²⁸ JP RWEE Final Evaluation (2021), Global Food Security, volume 37, June 2023, Assessing multi-country programs through a "Reach, Benefit, Empower, Transform" lens found it lacked a strategy to engage with men.

¹²⁹ Such as **GALS+**, **Business Action Learning for Innovation** (BALI), **Financial Action Learning System** (FALS), **Household Mentoring** and others. See more Annex VIII.

¹³⁰ After the concentration in ESA, WCA follows with 24 projects including HHM, but half of them are not being implemented. NEN and APR have included these methodologies in 10 and 8 projects. The HHM practice in IFAD LAC region is very limited, with some recent attempts. See Annex IV for the list of projects including HHM per region.

¹³¹ According to [available sources](#), the GALS implementation cycle varies from one to three years and the average cost ranges from USD 500 to USD 1,200 per GALS beneficiary.

¹³² The gender team acknowledged that budgeting and results reporting for GALS has not been consistent, particularly when project teams did not receive specialized support during design. At request of the TE team, the IFAD gender team tried to gather information from PMUs about cost and outreach of 10 recent projects which included HHM, but this information was not received on time for this report.

household (related to SO1), or to more women participation in governance structures of producers or self-help groups (SO2) or more equitable intra-household decision making or re-distribution of household tasks (SO3), see Annex XV. HHM is sometimes reported in connection to raising awareness about and managing potential adverse impacts from **gender-based violence** (GBV).¹³³ This aligns with IFAD's SECAP objectives to prevent or mitigate potential negative social effects associated to projects. IFAD gender experts interviewed also reported instances where GALS helped to prevent or reduce GBV due to the involvement of men in awareness sessions and to the group pressure for a gradual shift in socially acceptable norms. However, the latest SECAP version only mentions GALS for identifying project activities to close gender gaps (see Section II).

C. Factors affecting GEWE performance of IFAD interventions

103. **Key drivers of GEWE performance in IFAD projects identified by the TE include a thorough gender analysis for project design, the development of a project gender strategy or action plan, and sufficient adequate budget allocation.** PMU and PMD responses to the TE survey prioritized these three factors. At the TE design workshop, 28 IFAD staff and consultants working on gender and social inclusion placed higher importance on the availability of financial and human resources for gender and the overall commitment of senior PMU staff to implement GEWE activities (See Annex XVI). The Qualitative Comparative Analysis (QCA) of 29 completed projects uncovered associations among these factors, such as the presence of a project gender strategy and securing financial resources for a PMU gender expert during both design and implementation.¹³⁴ The box below and Annex XVI offers more information about the combination of factors to obtain a high gender rating (5 or 6, this is satisfactory or highly satisfactory) according to the QCA.
104. **Information on key factors affecting GEWE performance is not systematically reported in IFAD's documentation.** All interviewees stress the significance of the early development of project gender strategy/action plans, yet systematic reporting on this aspect is lacking, despite indications that delays are frequent.¹³⁵ Only a small number of projects provide information on whether they had sufficient financial resources for gender activities during implementation with little and dispersed information regarding the effective budget for GEWE.¹³⁶ The self-assessment reports do not discuss the potential disruption caused by corporate reforms and changes affecting the availability of human resources that possess the necessary expertise and experience. The IOE CLE decentralization highlighted how the reassignment process has affected the operational cycles (see also Section VI).
105. **The QCA identified a correlation between the engagement of national institutions specialized in gender or women issues in projects and achieving a high gender rating in projects.** For instance, **Djibouti** PRARV-PECHE reported working with the Ministry of Women Affairs as an implementing partner for specific activities. Other government agencies with a gender-related mandate were engaged in **Senegal** PAFA-E (the National Directorate of Women in Livestock), in **Vietnam** SRDP, CRRP and AMD (provincial women's unions) and in **China's** YARIP (Women Federation). PCRs attribute gender achievements to the

¹³³ Several projects claim to have contributed to reducing domestic violence among GALS participant households. This was also mentioned by GALS trainees during TE field visits in **Kenya**, in some of the counties with the highest rate of GBV in the country. IOE's CSPE in **Uganda** (2021) also found women participating in household mentoring had fewer instances of gender-based conflicts than before.

¹³⁴ Approximately half of the projects that had gender strategy and/or budget at design had a gender expert or focal point in PMU at design, and the expert was available during the implementation phase.

¹³⁵ Among the completed projects, several PCRs said the gender strategy was implemented too late to bring about significant changes (mid-term or after): **Moldova** IRECR, **Georgia** AMMAR, **Nigeria** CASP, **Kyrgyzstan** LMDP II, **Nicaragua** NICADAPTA. This was also mentioned in several supervision reports of ongoing projects covered in the country case studies. As an example, **Cameroon** PEA-J and PADFAII finished their gender strategies 2 and 2.5 years after project's launch, leaving only some years to implement it.

¹³⁶ The TE team reviewed Gender information in the Project Implementation Manual and in the COSTAB.

participation of these implementing partners, a factor identified by the QCA as a sufficient dimension leading to a high gender rating. Other examples of this were found in the country case studies. Other factors found necessary for a high rating are outlined in the box below.

Box 16

Dimensions necessary and/or sufficient for a project to obtain a high gender rating at completion

Necessary dimensions: (1) high percentage of financing from IFAD (more than 50% of total cost); (2) the development of a Project Gender Strategy from design; (3) inclusion of activities related to rural finance with explicit GEWE objectives; and (4) having other implementing partners in addition to the Ministry of Agriculture.

Sufficient dimension: The analysis found that the presence of women's associations as project service providers (or among implementing partners) was more frequently present in projects with high gender rating. This factor was single-handedly sufficient for the project to have a gender rating 3+ (Super Subset Analysis)¹³⁷.

Source: QCA applied to 28 completed projects (all the ones approved since the gender policy).

106. **The QCA revealed a combination of factors influencing a high gender rating for projects in high-income countries, which were distinct from those in low-income countries.** In low-income contexts, having a project gender strategy and engaging "special" implementing partners, alongside the typical IFAD partner (the Ministry of Agriculture) proved sufficient for a high gender rating. Conversely, projects in high-income contexts obtained a low gender rating, even when equipped with a gender strategy, if additional implementing partners were absent, and there was no gender expert in the PMU. In addition, projects with a PMU gender expert received a low rating if there was no specific budget for gender at design and there were no additional implementing partners. See Annex IV for more information on the QCA methodology and further details on the models covering various combinations leading to high or low gender ratings in Annex XVI.
107. **Adapting project gender strategies to situations of fragility needs to be strengthened.** IFAD is committed to expanding its presence in such contexts and is actively modifying its business model to better align with the unique challenges posed by fragile situations. Recent analyses conducted by IFAD management found better gender performance of IFAD projects in fragile contexts compared to non-fragile contexts.¹³⁸ However, beyond aggregated figures of gender ratings, the additional vulnerability caused by fragility requires adapting gender approaches, as IFAD senior gender staff recognised in TE interviews.
108. An examination of the implementation of two IFAD-supported projects in **Cameroon** affirmed the incomplete adaptation of IFAD gender approaches in situations of fragility.¹³⁹ As observed by the IOE SRE of countries with fragile situation in the G5 Sahel, the TE found that the fragility situations in Cameroon are treated as risks to be managed rather than problems IFAD can directly contribute to solving or preventing, proposing actions to the conflict/crisis-related drivers. This observation also applies to PADFA II, validated as a gender transformative project. Some of the insights from local rural people interviewed for the TE are at odds with the information in IFAD documents about the same situation, as outlined in the box.

¹³⁷ There are six projects which included women's associations as project service providers (or among implementing partners): the three in **Vietnam**, one in **Guinea Conakry**, in **China** Qinghai Liupan MAPRP and **Senegal** PAFA-E.

¹³⁸ RIDE 2022 found that the average ratings for gender were better in fragile contexts during IFAD11 than for non-fragile contexts. The IFAD July 2022 portfolio stock take also took a deep dive on fragility, where GEWE was also among the areas with highest performance (gender equality and women's participation, is the expression used).

¹³⁹ **Cameroon** has been affected by a multifactor crisis during the evaluation period. IFAD has designed and implemented programmes in zones affected by insecurity (Northern regions) and by the socio-political crisis since 2017 (Northwest). This has affected projects participants and local implementers and displaced populations to the projects' areas.

Box 17**Adapting GEWE practices to contexts with fragility situations: the case of Cameroon**

IFAD documents of the young rural entrepreneurship programme (PEA-J) recognized that “the socio-political situation” in the Northwest region slowed down the incubation of young entrepreneurs. Ad-hoc measures in collaboration with the administrative authorities to support project participants in this zone were recommended, with the use of local NGOs as the sole mitigation measure mentioned.

Key challenges affecting the viability of business plans as reported in interviews with young men and women entrepreneurs from Northwest Cameroon include: (i) the need to relocate their activities due to the insecurity situation, (ii) difficulties in accessing essential agricultural inputs, and (iii) challenges in selling products and repaying credits due to unexpected lockdowns¹⁴⁰. Despite these difficulties, the possibility of deferring debt, or providing debt relief through a contingencies budget line was not considered.

PADFA II, a GT-validated commodity value-chain project, was designed during the ongoing sociopolitical crisis in the Northwest and the insecurity crisis in the Far North. However, it only incorporated slight changes during implementation across these regions, relying on local staff and contractors and relocating key project activities in the capital city of a “stable region” close to Northwest.¹⁴¹

Focus groups with cooperatives members and the local NGO in the Northwest revealed the widespread impacts of the crisis, including loss of relatives or neighbors and disruptions to livelihoods. The PADFA II gender diagnostic in June 2022 also highlighted these issues. The local NGO started collecting data about additional “vulnerability arising from the conflict” but lacked the capacity to provide much needed psychosocial support for rural men and women to cope with these traumatic situations. Staff members were not trained for this, and they expressed the need to support themselves, as they are part of the same communities. Local staff suggested that exchanges with staff in other African countries dealing with similar situations would be really helpful.

Source: Desk review, interviews and field country visits (May 2023).

D. Assessment of recent efforts towards gender-transformative programming

109. As discussed, individual GEWE practices included in IFAD projects, in combination with other key contextual factors, can contribute to challenging social norms. In addition, significantly, in 2016 IFAD introduced a new commitment to approve new project designs which are validated by IFAD itself as gender transformative (See below and Annex IX).

Box 18**Definition of GT projects at IFAD**

A gender transformative project actively seeks to transform gendered power dynamics by addressing social norms, practices, attitudes, beliefs, and value systems that represent structural barriers to women’s and girls’ inclusion and empowerment. Such a project uses a gender-transformative approach, creating opportunities for individuals to actively challenge gender norms, promoting women’s social and political influence in communities, and addressing power inequities between people with different gender identities.

Source: IFAD (2019) Framework for Implementing Transformational Approaches to Mainstreaming Themes.

110. **A significant proportion of IFAD GT-projects are in Low-Income countries and in Fragile and Conflict-affected situations.** From 2019 to September 2023, IFAD approved 47 projects validated as gender transformative (44% of total of 108 projects approved and 37% of total financing value of USD 13.7 billion). Although there are no formal regional quotas, all regions exhibit a similar percentage of GT-validated projects in relation to their respective portfolio. Results show that 36% of GT projects are in Low-Income Economies against 28% of non-

¹⁴⁰ However, according to exchanges with the team in charge of the completion report of PEA-J, entrepreneurs from the zone affected by the crisis did not show worse repayment figures than those in other regions covered by PEA-J.

¹⁴¹ Some interviewees from the government claimed they thought the socio-political crisis was going to be temporary.

GT projects and 38% of GT projects are approved in fragile countries against 31% of non-GT projects¹⁴².

Box 19

Gender-transformative projects validated at IFAD from 2019 to September 2023

- % of GT projects in relation to the regional portfolio: 44% in APR, NEN and WCA; 43% in LAC and 42% in ESA.
- Number of GT projects (47 in all regions): 15 in WCA, 11 in APR and ESA, 6 in LAC and 4 in NEN.
- Eight countries have approved two GT projects: Four are low-income countries (Chad, Mali, Niger and Zimbabwe); two lower-Middle-Income countries (Burkina Faso and Cambodia); and two are upper-middle Income countries (Brazil and China).
Burkina Faso, Chad, Mali and Zimbabwe are also Fragile and Conflict Affected countries.

Source: TE calculations, on the basis of data provided by OPR.¹⁴³

111. **Some governments and IFAD operational staff are wary about the cost and requirements of GT programmes.** Some interviews with government and IFAD operational staff indicated inconsistent understanding about concepts related to gender transformative changes. Moreover, some intentionally avoid GT validation, fearing it might complicate implementation or overpromise given the country context. In other cases, interviewees at various levels of government acknowledged IFAD country teams pushed to address the root causes of gender inequality in a project, but there is uncertainty about getting full consensus regarding the necessity or feasibility of such an approach. Additionally, some qualitative contributions to the e-survey and interviewees indicated they had insufficient information about cost implications, and they lacked examples for learning how to design and implement a GT project. The TE found that information about the cost of measuring empowerment at baseline for GT-validated projects is scant.¹⁴⁴
112. **The quality of the GT-validated project design reports reviewed is variable, especially when considering some of the expected criteria.** The TE examined a purposeful sample of sixteen PDRs that received a high gender rating at design (eight validated as GT, other eight not validated as GT). When applying the criteria for a project to qualify as GT, some lack sufficient detail on the gender analysis or how they propose to address the third strategic objective of the gender policy. Additionally, the gender transformative pathways are not always clear (See the list of PDRs reviewed in Annex IV and detailed findings in Annex IX).
113. **Country visits interviews and the desk review unveiled confusion about what to measure for GT-validated projects, contradicting the more positive perception of respondents to the e-survey.**¹⁴⁵ Interviews with IFAD senior gender staff revealed that the decision on a cost-effective indicator for M&E in GT projects was not finalised when IFAD11 was committed to approving GT project designs in 2019 (see Box 7 in Section II). Therefore, the first batch of projects validated as gender transformative at IFAD proposed different indices and

¹⁴² The TE compared the location of the 47 GT-validated projects with the rest of the portfolio approved during the period (61 non-GT projects).

¹⁴³ As per IFAD management calculations, the analysis included Sierra Leone AVDP, approved by EB in 2018 and validated GT during implementation, and the additional funding of Nigeria VCDP, GT-validated in 2019.

¹⁴⁴ The TE review identified only two GT PDRs containing data on costs to calculate empowerment at project baseline: USD 70,000 (**Argentina** PROSAF) and USD 125,000 (**Kenya** KeLCoP). The other projects either did not detail this cost in the budget or included it with the overall project surveys expenses.

¹⁴⁵ Most (81%) of respondents to the e-survey indicated to have a clear understanding on what to measure in an IFAD GT project. However, many interviewees still mix the requirement of measurement the IFAD empowerment indicator at baseline with the calculation of a version of WEAI done for impact assessments.

methodologies to measure empowerment¹⁴⁶. Some IFAD staff and government partners still confuse RIA's efforts to measure women empowerment at completion with the simplified version of IFAD's empowerment indicator for GT-validated projects (see Box below and Annex X). Additionally, some interviewees expressed concerns about the ability of the IFAD empowerment indicator to capture changes in degrees of empowerment at individual level and intra-household levels, which could be linked to IFAD interventions. The IFAD empowerment indicator has only been used in GT-project baselines as of 2024, following the corporate outcome indicator guidelines. Therefore, it is premature to assess its value addition.

Box 20

Differences between the empowerment indicator and Pro/I-WEAI, as used at IFAD

IFAD's empowerment indicator (EI) assesses personal empowerment within IFAD project implementation areas and communities, focusing on domains relevant to IFAD's operations. In contrast to Pro-WEAI, the indicator compares the situation of **men and women in the project area**, not within the same household. The calculation of the IFAD EI involves interviewing only one person per household, whereas Pro-WEAI's individual questionnaire involves both an adult male and an adult female in a household with two adults. Pro-WEAI incorporates a control group, while the COI guidelines for EI calculation do not stipulate this as a requirement.

The introduction of the **IFAD empowerment indicator** aims to enhance the **quality and rigor of data collected during project M&E** at baseline and endline, regarding community-level empowerment as a project outcome. The responsibility for calculating the EI lies with PMU staff, country statistics offices along with private firms. In contrast, **I-WEAI** represents a more sophisticated methodology utilised **for impact assessments** conducted by the IFAD's RIA Team. This assessment is carried out for a set of completed projects and allows for the examination of **GEWE intrahousehold dynamics**. I-WEAI achieves this by surveying both men and women from the same household, comparing their situations with control groups.

Source: Thematic evaluation interviews and document review¹⁴⁷

114. **Beyond measuring empowerment at project baseline, a challenge lies in ensuring that the identified gender gaps are addressed.** Various sources emphasise the urgency of strengthening the overall project M&E strategy and incorporating activities that specifically target the gender gaps identified in the baseline studies.¹⁴⁸ This entails providing additional support to project teams in distilling recommendations from baseline analyses and addressing the implications of these gaps in project activities or a gender strategy/action plan. Typically, baseline studies are conducted by external consultants¹⁴⁹, while the responsibility for implementing key actions to address gender inequalities lies with the PMU, usually managed by the director and the associated gender or social inclusion expert, if available. According to interviewees, the need for additional IFAD support in this area was identified in 2022 by the IFAD gender team at headquarters. The

¹⁴⁶ **Cameroon** PADFA-II mentions WEAI (IAFA in French), **Tunisia** IESS Kairouan and **India** Nav Tejaswini mention Pro-WEAI, **Kenya** KELCOP mentions WEAI and Pro-WEAI in different sections of the PDR, **Cambodia** Sambaat mentions the A-WEAI, **Argentina** PROSAF proposes the IFAD empowerment indicator. The team could not access to the baseline report of **Cambodia** ASPIRE AT. **Morocco** PRODER does not mention any indicator to measure empowerment, despite being GT validated.

¹⁴⁷ The level of effort required for studies assessing the baseline situation in community-level empowerment, using the IFAD empowerment indicator, differs significantly from more comprehensive assessments using a version of the WEAI. Information from RIA indicates that the I-WEAI saves about 25 minutes (approximately 20% of the cost) compared to the standard Pro-WEAI questionnaire, which takes around 120 minutes to administer to one male and one female member of the same household. The estimated cost of each impact assessment, including I-WEAI, is on average US\$350,000, covering both data collection and analysis. This is a rough estimate and may vary depending on factors such as additional enumerator visits or logistical considerations.

¹⁴⁸ Interviews in the field-level country missions, discussions with key IFAD gender staff at headquarters, supervision mission reports of GT projects (**Kenya** and **India**).

¹⁴⁹ The e-survey found that 75% of PMU staff (only 58% in the NEN region) and 63% of PMD respondents affirmed in-country technical expertise to measure GT change exists.

challenge of building a roster of local consultants with expertise to support surveys, including women's empowerment measurement, is still not resolved. Additionally, involving rural farmers themselves in developing locally appropriate change metrics could help to customise questions and methods to monitor trends¹⁵⁰.

Key points about IFAD's contribution to GEWE performance (Section IV)

- Average completion **ratings for the promotion of GEWE in IFAD projects** have shown a decreasing trend in both self- and independent evaluation from 2012 to 2023. The **disparity between self and independent evaluation** narrowed after 2018. Shared criteria for independent and self-evaluation (outlined in the 2022 IFAD Evaluation Manual) should contribute to further closing this disconnect.
- Thorough review of the **gender information in self-assessment** reports (supervision/implementation support and project completion) serious quality challenges were found. Outreach metrics (percentage of rural men and women participating in projects) are often the only information provided. **Factors contributing** to the weak gender outcome self-reporting at IFAD are related to inconsistent availability of expert support in all missions and wrong perceptions by many IFAD and PMU staff about what is required and what is sufficient for assessing GEWE performance.
- The predominant GEWE strategy used by IFAD COSOPs, projects and grants is to support rural men and women to gain access to key productive assets (**first strategic objective of the gender policy**). The TE identified some good practices and results in some contexts.
- Supporting rural women to fully participate in private producers' governance institutions (**second strategic objective of the gender policy**) is useful, but women still tend to occupy accounting or administrative roles. *Cerrando Brecha*, piloted in some IFAD projects in Central America, but its effects are not yet well captured in IFAD's M&E to promote its scale up.
- Time and labour-saving infrastructure and equipment to reduce the drudgery of tasks typically performed by rural women (and children) are commendable (**third strategic objective of the gender policy**), but they are not accompanied by clear pathways to map their contribution to GEWE.
- IFAD has been at the forefront of implementing gender transformative approaches in rural development since 2007. The TE highlighted some interesting GEWE practices contributing to address some **root causes of gender inequality**, such as to facilitate access to land and other natural resources (or tenure security). Gender Action Learning system (GALS) and other household methodologies have been supported by several grants and used in almost one hundred investment projects. However, GALS' assumed benefits are still poorly reported in IFAD M&E systems, with some exceptions.
- Among the **factors affecting GEWE performance** of IFAD interventions, the TE confirmed that a timely and good quality gender and poverty analysis informing project design is of utmost importance. Yet, evidence from the TE confirms findings from ESN on targeting. The quality of gender in project designs is variable, which could be partly explained by internal changes analysed in Section VI.
- IFAD has approved 47 **GT-validated project designs** in the five regions it works, as of September 2023. The TE identified challenges in widespread misunderstanding of what gender transformative programming entails, both conceptually and operationally (cost and good practices both for design and early stages of implementation).

¹⁵⁰ The TE did not find the use of other methods such as Most Significant Change or Outcome Harvesting in IFAD's portfolio M&E or outcome measurement.

V. Performance of non-lending activities for GEWE results

115. Section V analyses the performance of non-lending activities (NLA) in relation to the promotion of GEWE. It starts with presenting results from an analysis of gender global knowledge generation at IFAD and it presents an analysis regarding the extent NLAs are leveraged to improve the results of IFAD COSOPs and project investments. Section V outlines the prospects of sustainability and scale up of GEWE approaches, including through policy engagement. Evidence from the country case studies, desk review of knowledge products and internal documents related to partnerships, IFAD's website analysis and information from supplementary-funded programmes, as well as interviews with IFAD's senior management, operational staff and external partners are all used throughout Section V.

A. Knowledge management and partnerships at the global level

116. **IFAD's engagement in global gender multi-agency groups and programmes that promote gender equality have enabled it to maintain its visibility on GEWE in rural development.** Interviews and the review of a decade of RIDEs showed that IFAD actively participates in various international fora and working groups with other development partners (See Annex XVII for examples). However, no assessment is available on the additional value of such engagement or results. Through the two joint programmes and the Gender Transformative Mechanism, IFAD becomes an institutional contact among UN partners and others for global gender programmes.¹⁵¹ Various interviewees, especially those from the UN RBA, are appreciative of IFAD's contribution at this level.

117. **The two JPs and the GTM provide a valuable platform for IFAD to unpack further corporate ideas on transformative approaches and a platform to ensure wider dissemination of such ideas.** According to IFAD gender specialists, JP coordinators and other IFAD staff, supplementary funds on gender have been instrumental in moving the gender transformative agenda forward conceptually.¹⁵² This has also helped to organize numerous corporate knowledge events on gender and social inclusion¹⁵³, complementing dissemination events led by JPs. The final evaluation of the initial phase of JP RWEE found that the budget for knowledge management was insufficient, which was rectified for the subsequent phase. The JP-GTA maintains effective web communication with an increasing number of knowledge products (see box below). However, due to the early stage of these activities, the progress reports do not yet reflect their impact.

¹⁵¹ The Joint programmes were highlighted as good practice by the 2021 IOE Joint evaluation of collaboration among the UN RBAs. Additionally, a longstanding RBA headquarters gender working group convenes quarterly coordinating a range of activities that include a synchronized participation in global forums for policy and advocacy, raising awareness, and enhancing capacity.

¹⁵² For instance, the JP GTA funded the development of recent guidelines for measuring GT change, available [here](#); the GTM organized a workshop in June 2022, under the leadership of IFAD's Gender and social inclusion team, to build a theory of change for gender transformative changes in agriculture, with the participation of the BMFG, the University of Washington and various IFAD divisions. It also led an event at COP28 to emphasize how climate change is amplifying gender inequalities and posing unique threats to women's livelihoods, health and safety.

¹⁵³ The IOE CLE on KM (2024 forthcoming) found that 10 percent of IFAD knowledge events were focused on gender and social inclusion, just behind those concerning organizational updates or general programme management issues.

Box 21**The Joint Programme on Gender Transformative Approaches and its means of communication.**

- The JP GTA **website**, available in English, French, and Spanish, functions as the primary repository for knowledge related to the Programme. In the 2022-23 period, the website experienced a steady increase in monthly users, doubling its web traffic, with an **average** of 900 monthly users. The top four countries visiting the JP GTA website are the **United States, India, Italy, and Kenya**. The majority of users (74%) access the website from desktop computers rather than mobile phones or tablets.
- The website is complemented by the JP GTA **Quarterly Update**, disseminating news, information, and knowledge while driving traffic to the website.
- Additionally, the JP GTA collaborates closely with the RBA relevant communications teams. IFAD has been particularly proactive in disseminating information within its **Gender Network**. Social media posts related to the programme can be found using hashtags such as #JPGTA, #GenderTransformativeApproaches, or #EnfoquesdeGéneroTransformadores
- The JP GTA expanded the reach of its **mailing list**, with a total of 2,109 recipients by October 2023. This growth was achieved through **events and campaigns** and **internal engagement with RBAs**.

Source: Data received from JP-GTA coordination team.

B. Performance of non-lending activities to improve gender approaches and results in IFAD interventions.

118. **Most IFAD GEWE NLA are focused on the global level, with a limited connection to COSOPs or country programmes.** Respondents of the TE e-survey were divided about the strategic use of grants and joint programmes to enrich GEWE results in the investment portfolio¹⁵⁴. Factors identified related to inefficiencies of administrative systems in partner agencies and IFAD, and a high turnover of IFAD staff leading to missed opportunities for linkages with ongoing projects, among others. Some gender grants also contributed to generating and disseminating knowledge, but not always reaching rural women and men. In addition, global and HQ-managed gender programmes and grants are poorly integrated into COSOPs (More details in Annex XVII).
119. **IFAD maintains a dedicated website on gender issues, providing access to key documents, although these are not always available in all UN languages needed.** The dedicated [webpage on gender](#) is widely used according to download data, but the number of publications on gender is behind other themes and not always available in all IFAD languages¹⁵⁵. Most (64%) of PMU staff indicated that IFAD GEWE resources are not always available in the language needed (15% said they did not know). This percentage is higher for respondents from LAC (78%) and in APR (69%), and lower for IFAD PMD respondents (59%, although 28% chose the option don't know).
120. Widespread shortcomings in project M&E systems hinder the generation of objective information about gender approaches and pose a threat to their further use in IFAD interventions. Although the majority of respondents to the TE e-survey expressed optimism about the capacity of M&E and KM systems to capture and disseminate GEWE practices,¹⁵⁶ the country case studies identified numerous gaps in the M&E systems concerning gender (See Annex XIV). While gender lessons

¹⁵⁴ Over half PMD respondents (53%) agreed they are not strategically used to enrich the results of investment projects, while 27% answered that they did not know. However, as one survey respondent from APR indicated, "Strategic use of grants is important in a context where many partner governments are becoming increasingly restrictive in the types of development activity they are willing to finance with debt (i.e., IFAD loans)."

¹⁵⁵ IFAD gender glossaries in 2017 and 2021, available online, were good attempts, but insufficient.

¹⁵⁶ More than two thirds (69%) of PMD respondents considered that the current M&E and KM systems effectively capture good GEWE practices and that they are shared with relevant IFAD stakeholders (74%). Female PMD respondents exhibited slightly lower positivity on these two points (65% and 70%) compared to male respondents (73% and 78%, respectively), although the statistical difference is weak.

from projects are generally incorporated into PDRs (especially between successive phases of the same project), country case studies indicate a limited exchange of these lessons across the portfolio. To improve horizontal knowledge transfer, some PMU staff centralized gender issues for the entire IFAD portfolio, with variable success. A good example was found in relation to the South-South (Portuguese-speaking countries) sharing and discussion of the implementation in **Brazil** of *Cadernetas Agroecologicas* (Agroecological books), See Annex XVII.

121. **“Learning routes” (LR) have emerged as a potential tool to draw insights from successful gender approaches which allow them to be tailored for specific contexts.** For many years, IFAD have been collaborating with PROCASUR to organize learning routes, which provide experiential learning opportunities for farmers and development practitioners. Some specifically focused on gender issues: **Uganda** on [gender and rural microfinance](#), and addressing [women’s land rights in East Africa](#).¹⁵⁷ In June 2023, under the JP-GTA, a LR took place in **Malawi** with a [focus on integrating GTAs in rural development interventions](#). These exchanges by project staff were identified as helpful by PMU staff in the TE e-survey.

C. Prospects of GEWE sustainability and scaling up

122. This section analyses the evidence related to the **sustainability** of GEWE practices or GTAs tested by IFAD, as well as the challenges associated to ensure the net benefits of IFAD support to GEWE will continue afterwards. It delves into partnerships, capacity building of key implementing partners and **scale up** efforts by other partners or by national governments, and the efforts and results of **GEWE policy engagement** to date.
123. **Opportunities for key partnerships and scaling up GEWE efforts are not consistently integrated into COSOPs.** According to the 2015 IFAD GEWE scaling up note, the identification of opportunities for policy engagement, partnership-building and scaling up should occur upfront at the COSOP and project design stage. The note also emphasizes the proactive exploration and promotion of strategic partnerships with government programmes targeting women and the poor.¹⁵⁸ Moreover, IFAD developed in 2016 an approach to policy engagement and included “the need to plan for policy engagement on GEWE” as a criterion for a project design to be considered as gender transformative.
124. There is limited evidence in the reviewed COSOPs and PDRs on efforts related to inclusion in policy engagement which takes place between IFAD senior staff and governments. Examples such as graduation approaches used in **Tunisia** and **Kenya** can provide valuable insights to programming and policy. Less than half of the reviewed 25 COSOPs referenced national gender policies/strategies or established linkages to previous commitments expressed by States such as the CEDAW. This could reinforce the relevance of gender work in rural areas to government partners and promote potential partnerships with other development agencies.
125. GEWE policy engagement has been very limited in the ongoing portfolio and GT-validated PDRs provide limited detail on this. As analysed in Section III.D.a, COSOPs seldom mention the GEWE legislative context. Project investments sometimes include funding specific studies with the aim of influencing policy related to gender equality, but its results are not analysed or evaluated. Despite GEWE policy engagement being a key element of GT-validated projects at IFAD since 2019, only one (**Kenya** KeLCOP) of the eight reviewed provide more details (it

¹⁵⁷ Other LRs reported include South-South knowledge sharing on household methodologies in Nepal (IFAD UNSWAP report, 2014) and PROCASUR and IFAD Sudan organized a workshop in Uganda on how to implement learning routes as part of the project Knowledge Management Tools for Enhanced Project Performance (IFAD UNSWAP report 2016)

¹⁵⁸ Such as government programmes promoting women’s rights related to land, enterprise, and social transfers.

aims to influence the inclusion of specific challenges faced by women in the livestock policy development).¹⁵⁹

126. **At the operational level, IFAD does not have consistent criteria for engaging country and local partners to reach specific groups of rural men and women which lessens ownership and sustainability.** The country case studies and the review of completed projects revealed that there are different levels of association to engage with the Ministry of Women’s Affairs (MOWA) or its equivalent in each country, including at the central or sub-national (provincial/local) levels.¹⁶⁰ Evidence from various case studies suggests that associating MOWA was not always the most effective strategy. In some instances, associating with Gender Focal Points in the Ministry of Agriculture was reported to produce better results, as noted in **Cambodia** and **Ethiopia**. In certain instances, IFAD-supported projects have involved other government authorities or women’s organizations.¹⁶¹ Additionally, UN Women and UNICEF have been associated with the implementation of IFAD activities in some IFAD projects and NGOs are frequently associated as service providers (see examples in Annex XVII).
127. **The cumulated IFAD experience of implementing HHM in its portfolio demonstrates the need for long-term support for scale-up by country stakeholders.** A measure of success in various grants and JPs was that the HHM piloted are now used more widely in IFAD’s investment portfolio. However, many of them are not effectively implementing these methodologies (See Section IV.B.b). The GALS approach operates on the assumption that GALS champions and trained farmers once equipped with the training and experience, will replicate the training process and disseminate the acquired knowledge. This is often cited as a primary exit/sustainability strategy in IFAD project documents, although others mention challenges linked to budget availability and fatigue among trainees. Recently the empower@scale grant has been working to enhance in-country HHM capacities through the support to three empowerment learning centres, each with different levels of sustainability. Instances were identified where (sub)national governments adopted GALS following their testing through IFAD-supported interventions in **Nepal, Malawi, Uganda** and **Rwanda**. More information is available in Annex XVII.
128. **Cerrando Brecha did not have a proper sustainability strategy with relatively recent efforts to facilitate its application without external support.** In **El Salvador**, key actors associated with in implementing *Cerrando Brecha* reported efforts to train staff from the gender unit of the Ministry of Agriculture to use the methodology. However, key practitioners acknowledged that the methodology is still dependent on PMU staff and project funding. From 2021, efforts to simplify the methodology and create a pool of local trainers have been accompanied with its piloting in **Ecuador**.

¹⁵⁹ This confirms the findings from the 2022 management-led review of 28 GT-validated PDRs, where 60% of projects omitted any reference to policy engagement or noted policy engagement as an activity but providing no further details. The other 40% provided details about the policies they would engage with and how that would be achieved.

¹⁶⁰ Partnerships with MOWA focused on project implementation (**Ethiopia, Cambodia, Tunisia**, slight involvement in one project in **Argentina**) or at project design (**Cameroon**). In **Mauritania, Cameroon, Cambodia**, it was reported that MOWA staff were part of the projects’ steering committees, without clarifying the level of their specific role (see also Section IV.C).

¹⁶¹ For instance, in **Tunisia**, the Independent Office of Rural Women at the governorate level, the Ministry of Social Affairs, the Regional Commissioner for Women, Family, and the Elderly were formally engaged through partnerships to improve targeting and address gender-based violence; in **China** and **Vietnam**, favorable gender outcomes were associated to the involvement of women’s unions and federations.

Key points about the Performance of non-lending activities for GEWE results (Section V)

- IFAD has effectively **partnered with Rome-based agencies** to conceptualize gender transformative change in the context of food security, nutrition and sustainable agriculture. This has helped IFAD to maintain its visibility despite its reliance on a small, overstretched team working on GEWE at headquarters.
- IFAD's partnerships at the global level have been effective in **creating knowledge on GEWE and sharing** such knowledge among a certain type of stakeholders. However, the **complementarity** of these non-lending efforts to enrich gender approaches in IFAD interventions at country level is limited.
- **Gender knowledge from IFAD country interventions** is mainly transmitted in countries where various phases of the same project are supported over the years. The TE found limited horizontal transmission of gender knowledge across projects and regions. "Learning Routes" and other isolated South-South cooperation initiatives are promising but not used at the necessary scale to ensure learning from successful GEWE project experiences and failures to inform staff in charge of designing and implementing IFAD interventions.
- Several factors hinder the possibility of **scaling up IFAD GEWE (and GTA) approaches** or using them in **country-level policy engagement on GEWE**. Among factors identified are the limited integration of these opportunities into COSOPs, the weak project M&E and the incomplete assessment of cost and benefits of tested GEWE approaches and practices.
- Recent initiatives to scale-up of HHM by some African countries can be linked to **IFAD's long-term support** through grants and investment projects. Efforts to create in-country capacities for HHM/GALS and *Cerrando Brecha* are fairly recent, so it is not yet possible to assess their results in terms of sustainability of these methodologies.

VI. Organizational fit-for-purpose to deliver on gender-related commitments.

130. This section assesses IFAD's readiness (as an organization) to deliver on its commitments to promote GEWE. This section is directly related to the green boxes. Section VI presents the results of the assessment of the extent to which gender has been mainstreamed throughout the Fund. The analysis followed a gender audit methodology covering the internal structures, processes, organizational culture and human and financial resources. Section VI reviews the underlying reasons behind the performance gaps identified in earlier chapters and assesses where the recent changes will be sufficient to close them. Evidence comes from an analysis of internal documents, financial and other data, staff survey results, interviews with a broad range of IFAD staff and consultants and with gender staff from other development agencies. The analysis of UNSWAP reporting at IFAD also provided key evidence for this Section.

A. Human resources

131. **Over time, there has been a reduced focus on how key components of IFAD's human resources will contribute to fulfilling GEWE commitments.** In response to a recommendation from the 2010 IOE CLE on gender, IFAD commissioned a review of its human resources to meet its gender-related mandate (referred to as "gender architecture") which found it fell short compared to other development organizations. The 2012 gender policy set to strengthen key elements of human resources and clarify responsibilities, including among senior management. The internal gender action plan in 2016 restated the key roles of human resource components, adding gender focal points in IFAD country offices and in PMUs, implementing partners, consultants and external partners. The 2019 Gender Action Plan lacks explicit details on key human resources and how they will operate to fulfil commitments. Instead, the plan refers to gender and social inclusion staff at headquarters and in all regions and the results framework has activities for gender focal points, Country Directors, ICO staff, PMUs and consultants.

132. **a. The gender and social inclusion team with global responsibility Human resources within the gender and social inclusion team have increased since 2012.** Since 2012, the team has had a P5 Lead Technical Specialist and a P4 Senior Technical Specialist on gender and social inclusion.¹⁶² This was supplemented by one to two Junior Professional Officers (JPOs) from 2016 to 2021 and one to four long-term consultants/temporary professional officers (TPOs), based in headquarters. The P2 level JPOs were a critical part of the team providing country programme support, supporting supplementary-funded programmes and grants and contributing to corporate demands. At the time of writing this evaluation report, there are no JPOs in the team. Throughout IFAD, the long-term consultants are widely considered as [integral members of the team](#). They have managed supplementary-funded programmes and performed core tasks of the unit. In the course of this evaluation, two long-term consultants were recruited to join the team, serving as the new GTM Coordinator and Officer. See Annex XVIII for changes to human resources for gender-related work.

133. **The growth in human resources has not kept pace with the increase in workload of recent years.** The IFAD gender and social inclusion team is well respected across IFAD, however, the consistent feedback from interviewed stakeholders is that the unit is overstretched. The disparity between the amount of available human resources in the gender and social inclusion team and the workload has consequences for the quality of work that can be delivered. In

¹⁶² The P5 position was vacant for roughly one and a half years (2016-2018) at a time of internal reorganization. IFAD filled the gap through the recruitment of a Senior Gender Consultant and a Regional Gender Coordinator seconded to headquarters for six months.

interviews IFAD staff indicated that there has been a considerable increase in workload for team staff and consultants since 2018. Reasons for this increase are:

- a. The mainstreaming of social inclusion themes (since 2019) increased the amount of corporate work and requirements.¹⁶³ Additionally, each gender staff/consultant covers an average of eleven project delivery teams.¹⁶⁴
- b. More time is spent mobilising resources,¹⁶⁵ which was incentivised through staff performance evaluations from 2021. Plus, more time is spent on managing the funds to deliver gender commitments;
- c. In addition to the existing requirement for gender mainstreaming, the design and implementation support of gender transformative projects requires additional time, expertise and financial resources;
- d. The recruitment processes for some posts have been prolonged and, at times unsuccessful (see the duration of some vacancies in Annex XVIII).

134. **The global corporate work conducted by new staff in the gender and social inclusion team situated in decentralised offices was hampered due to the priority needs in the regions where social inclusion analyst positions were vacant.** The human resources of the team with global responsibility increased in 2022 with the recruitment of a P3 Technical Specialist on social inclusion and gender, located in Delhi, and a P4 on social inclusion - poverty targeting, located in Abidjan. However, they were co-opted to replace some of the work which should have been done by regional social inclusion analysts, which were vacant for 1.5 years in APR and for 4 years in WCA.¹⁶⁶ Analysis of their engagement shows that at least half staff's time has been spent responding to priority regional divisional needs at the programme level. This TE evaluation notes that social inclusion analysts have been appointed in APR, WCA as well as NEN during the period covered by this evaluation. Interviews also showed that the logic behind decentralizing positions with global roles is often not aligned with their functions.¹⁶⁷

135. **The gender and social inclusion team's ability to implement the gender action plan in 2023 and 2024 as well as ensure business continuity is jeopardized by both reassignment and decentralisation of the two pivotal staff positions.** In line with the ongoing HRD reassignment exercise, the incumbent filling the P5 post is due to be reassigned to a different position. A new incumbent will fill the P5 post¹⁶⁸. The P4 post (filled in November 2023) will be decentralised from IFAD headquarters to the Cairo office. These movements, represent a risk to the capacity of the gender team to continue supporting operations and, more broadly, deliver the gender action plan. The 2020 WFP evaluation on gender found that the rotation of senior gender advisors led to a loss of institutional memory and diluted the gender mandate.

b. Social inclusion and gender staff with regional responsibility

136. Staff responsible for social inclusion and gender in regional divisions have provided valued support to country programmes, capacity building of local partners and knowledge management. For example, according to the **India** country case study, the SI Analyst in APR facilitated workshops for project gender focal points from different IFAD-supported projects in India, which enabled them to share lessons

¹⁶³ The responsibility of staff and consultants increased from mainstreaming gender and targeting to mainstreaming gender, targeting plus persons with disabilities, youth, nutrition and Indigenous Peoples.

¹⁶⁴ In October 2023, 6 staff and consultants interviewed reported to participate in 6, 7, 9, 12, 14 and 17 PDTs.

¹⁶⁵ 2019 Gender Action Plan: "raise resources for supplementary funds (SF) while integrating them into IFAD's programme of work to multiply impact on the ground".

¹⁶⁶ The 2012 GEWE Policy committed to out-posting gender "advisors" in all regions. The Executive Management Committee agreed to fund these positions in APR, LAC and NEN in September 2016 and the eventual Social Inclusion Analyst positions were only advertised in 2018 due to internal restructuring and decentralisation.

¹⁶⁷ For example, responsibility for global corporate work on persons with disabilities or knowledge management or responsibility for managing consultants based in headquarters from a regional office.

¹⁶⁸ IFAD is the only RBA that does not have a director level position in the gender unit.

and learn from each other. Such activity stopped when the analyst position was no longer filled. IFAD country teams actively seek social inclusion staff to participate in missions region-wide; in part because they are cost effective compared to consultants.¹⁶⁹

137. **The effectiveness of social inclusion and gender analysts in the regions is impeded by their relative lack of seniority in comparison to other technical staff in regional offices.** Social inclusion analysts covering the technical subjects of targeting, gender, persons with disabilities, youth and nutrition and undertaking regional work are national officers at NOC level, except in NEN where the position is at P2 level. This is in stark contrast to regional staff covering environment and climate (P5) or other thematic areas such as rural finance, markets and value chains (P3, P4 or P5).¹⁷⁰ The respective levels of staff seniority convey a message to stakeholders in- and out-side of IFAD about the importance of different themes in its work. Unlike in other regional divisions, the gender and social inclusion analyst in LAC is not backed up by a more senior staff member on the same theme. However, this also reflects the relatively small number of regional staff, lower PBAS allocations and project financing and fewer missions per year and PDT assignments in LAC.¹⁷¹

c. Gender focal points

138. **The number of GFPs increased over the evaluation period, yet the current GFPs play a relatively minor role in gender-related work, signifying a loss of momentum.** The number of divisional and decentralised GFPs and their alternates increased from 17 in 2013 to 38 in 2022. In 2017, the gender and social inclusion team conducted training for divisional GFPs at headquarters and organized regularly “gender breakfast” meetings to discuss emerging issues and current trends. However, since 2018 these efforts have been hindered by staff movements and time constraints of the team members. In regions, the role of GFPs is unclear including how it is related to the role of Social Inclusion Analysts.¹⁷² IFAD reports that from 2019, there have been between 300 and 350 GFPs in PMUs. The network of PMU GFPs has also proved difficult to maintain without systematic recording in IFAD of PMU staff contact details.¹⁷³
139. Despite facing challenges, the current divisional GFPs are motivated to contribute to enhanced GEWE performance and the achievement of gender parity in the workforce. The GFPs currently based in HQ¹⁷⁴ and in the regions were interviewed by the evaluation. They emphasized the necessity to (i) improve clarity about their expected role; (ii) provide opportunities for collaboration and information exchange with other GFPs – this could include initiatives similar to “gender breakfasts” organized by the gender and social inclusion team from 2014-2018, and (iii) better coordinate with other divisional colleagues reporting on UNSWAP indicators and with the diversity and inclusion advocates (since 2022). Box 22 provides more information.

¹⁶⁹ As of October 2023, the three SI analysts participated in 13, 12, and 15 PDTs in their respective regional divisions.

¹⁷⁰ Note that positions on rural finance, value chains, and others hold a NOB and NOC position in regional offices, but their job titles acknowledge that they are “Country” Technical Analysts rather than staff performing regional work.

¹⁷¹ From analysis of ECG organigram (January 2023) and Oracle Business Intelligence operations dashboard and SKD PDT assignment dashboard.

¹⁷² The UNSWAP recommends to have Gender Focal Points (GFPs) or equivalent at HQ, regional and country levels, holding positions at P4 level and above. These individuals should have written terms of reference and dedicate at least 20 per cent of their time to GFP functions aligned with the entity specific mandate.

¹⁷³ This was evident during the evaluation. To launch the e-survey for PMU staff, the evaluation team had to reconstruct the mailing list of PMU staff, including gender/social experts, as the list was outdated.

¹⁷⁴ At the time of the TE GEWE, there were 11 (principle) GFPs and 9 alternatives in the gender and social inclusion team database.

Box 22**Key findings from interviews with Gender Focal Points (GFPs)**

- Both female and male GFPs (50 per cent) have been nominated to hold the role. Both are appreciative of the opportunity to learn and promote gender equality in IFAD;
- GFPs are mainly mid-level professionals rather than senior (4 out of 11 are P4 or P5);
- GFP related tasks include sharing gender-related information with their divisions;
- Most GFPs interviewed spend 5 per cent or less of their time on GFP related activities.
- Most GFPs are unaware of the ToRs for their role and the range of potential tasks. A minority have had limited engagement with or guidance from the gender and social inclusion team;
- While half of the GFPs have incorporated their role in their PES, only in 2 out of 10 cases has this responsibility been discussed with their supervisor.

d. Senior Management Gender Champion

140. **The Senior Management Gender Champion has primarily advocated for gender equality through the delivery of speeches and the publication of blogs.** Since 2018, the role of Senior Management Gender Champion is held by the Associate Vice President (AVP) of the Corporate Services Department. The incumbent regularly broaches the subject in speeches and blogs. Inputs are most evident towards the annual 16 days of activism against gender-based violence and as a member of the Executive Management Committee in the IFAD Workplace Culture task force.¹⁷⁵ Since December 2022, the gender champion role has been subsumed into the role of the Diversity Equity and Inclusion Champion, held by the same incumbent. This is a positive move that recognises the various forms of diversity (besides from gender) needed in IFAD's workforce, providing that in the future it does not result in less focus on gender issues. Other senior management figures have promoted gender equality outside of IFAD. Most notably the President and the AVP of the Strategy and Knowledge Department (SKD) have regularly integrated gender in [speeches in external fora](#).

B. Gender capacity**a. Supporting components to IFAD's human resources**

141. **While a steady supply of gender and social inclusion consultants remains essential to support IFAD operations, there is a lack of coherence across operational and technical divisions regarding their optimum management.** Staff in the gender and social inclusion team and social inclusion analysts in regional offices cannot directly support all IFAD-supported projects. The provision of good quality expertise on gender and social inclusion by consultants who are also up to date with the latest changes in IFAD's approach to GEWE is therefore important for the design, supervision and implementation support of projects. Currently, IFAD has several databases of consultants, which vary in terms of usefulness and functionality.¹⁷⁶
142. According to IFAD's website, the **Gender Network** aims to raise awareness and increase learning on gender issues and enable peer-support and access to technical backstopping, especially for IFAD-supported projects. It reportedly has over 2000 members representing different internal and external partners. During interviews, staff and consultants confirmed that the periodic emails they receive are useful to

¹⁷⁵ Workplace culture taskforce was established by the Executive Management Committee to develop a concrete and time-bound action plan to address the findings of the internal 2019 Staff Engagement and Workplace Culture Survey. Regular intranet blogs on workplace culture communicate the issues identified in staff surveys and provide updates on progress made towards fostering a conducive workplace culture.

¹⁷⁶ (1) The gender and social inclusion team developed a **database of gender and social inclusion consultants**, who received training. This was updated until the last years owing to limited time and other priorities; (2) ECG has developed its own **database of consultants to cover the mainstreaming themes**, but it is insufficiently granular for the Gender and social inclusion team; (3) HRD manages the **official corporate-level roster of consultants**. In addition, Country Directors and regional social inclusion analysts are developing a network of regional and local gender and social inclusion consultants, following IFAD's decentralization.

remain up-to-date on events, news and project lessons learned.¹⁷⁷ Although the emailing lists do not facilitate peer-support or two-way communication per se, the TE e-survey found there is still widespread satisfaction among operational staff with access to technical backstopping.¹⁷⁸ In 2020, SKD set up a more versatile community of practice, also called the **Gender Network**, using the [Dgroup platform](#). However, interviews indicate resources have not been allocated to manage this platform adequately, with a decrease in the number of messages posted per year.¹⁷⁹

b. Gender capacity in IFAD and among implementing partners

143. **The TE e-survey results show that half of staff and consultants in PMD and project management units in-country think they have received adequate training on GEWE to support operations.**¹⁸⁰ In line with UNSWAP stipulations to “meet” requirements, IFAD has undertaken GEWE capacity needs assessments at least every 5 years, in 2016, 2019 and in 2023 (see Annex XIX). These assessments have been focused primarily on operational staff. Interviews highlighted that time constraints were the main determinant for their lack of depth and follow-up. The absence of a consistent approach over the years makes it difficult to understand changes in GEWE capacity of key actors involved in implementing IFAD operations over time. When it comes to having received gender training in the past five years, respondents from PMUs in LAC region expressed higher agreement at 74 per cent, in contrast to the average across regions (58 per cent).
144. **The gender and social inclusion team has, on occasions, facilitated capacity development for IFAD staff and PMUs through regional gender clinics and support during project start-up.** In 2014, the team organized a regional workshop on targeting, gender and youth inclusion in Kinshasa for all WCA PMUs. At the 2019 NEN retreat, a full day was dedicated to gender and poverty targeting in IFAD country programmes.¹⁸¹ A similar exercise was also held in WCA. IFAD gender experts have presented at the launching session of various projects and have delivered online Gender clinics in 2019 in NEN, LAC and APR.
145. **There have been several initiatives to facilitate systematic awareness raising and basic training for staff and consultants on GEWE in both the workplace and in IFAD programmes.** The corporate induction webinar series includes a presentation about gender. This is then backed up by mandatory training on gender and DEI for new staff and non-staff (consultants and interns). Between August 2019 and October 2023, the mandatory gender training was completed by 921 women and 654 men (922 staff and 653 consultants)¹⁸². The mandatory DEI training has been supported by three talk events with expert speakers in 2022 and 2023. Training is also now available on how GEWE is evaluated in IFAD. The [online training](#) on the 2022 IFAD Evaluation manual jointly offered by IFAD Management and IOE, through IOE’s website, is a valuable resource.

¹⁷⁷ Before, the ‘Thematic group on Gender’ was the internal emailing list comprising the gender team, divisional gender focal points across the house, other interested staff and the Senior Management gender champion.

¹⁷⁸ The TE e-survey results show that support from IFAD’s gender and social inclusion specialists is appreciated by most respondents in operations, considering the actions they propose during field missions useful to improve GEWE performance (87 per cent from PMD and 92 per cent from PMUs)

¹⁷⁹ In 2020 40 messages, in 2021 59 messages, in 2022 35 messages, in 2023 19 messages. Note that a member of the evaluation team requested membership in October 2023, but a response was not received.

¹⁸⁰ Respondents from PMUs in NEN region were more in disagreement (62 per cent) compared to LAC (36 per cent) and the average across regions (49 per cent). Numerous comments from PMU respondents to the online survey requested more practical and longer training.

¹⁸¹ This included a high-level panel discussion on practices and experiences on gender and targeting in the region from government representatives and practitioners from **Palestine, Moldova, Sudan, Georgia and Tunisia**, as well as the first Gender clinic for improving the performance of projects on gender. Seven projects with rating of 4 and below closing in IFAD11 were selected to develop a gender action plan facilitated by IFAD gender experts.

¹⁸² HRD data from Learning Management System and the Performance Evaluation System. Statistics show that participation numbers have increased since the training was delivered online (101 people completed the in-person workshop between October 2019 and November 2021).

146. **IFAD's senior managers do not undergo tailored gender training as part of their orientation, as they do at WFP, FAO and UNDP.** The 2016 mid-term review of the IFAD's Policy on GEWE advised gender training for "Senior Management orientation". This initiative was not implemented, as it is done in other organizations, like UNDP where a Leadership for Gender Equality Certificate course was launched with for Resident Representatives in January 2022. The primary goal is to allow Resident Representatives to better advocate, negotiate, build effective coalitions and partnerships and lead internal and externally on gender equality. Interviews revealed it is now mandatory and recognised by a formal leadership certificate. Key operational staff have not received training to engage in policy dialogue on GEWE. PMD staff and consultants in the TE e-survey were split about having received adequate capacity building on GEWE to convey related messages to national implementing partners.
147. **Training sessions focusing on mainstreaming themes to enhance the skills of operational staff have had relatively limited attendance to-date.** The HRD commissioned study on IFAD's workforce composition in 2019 found that IFAD had a "significant gap" in technical expertise on cross-cutting themes and their interlinkages. In response, HRD and ECG created the "Mainstreaming themes in IFAD projects" training module¹⁸³ as part of IFAD's Operations Academy (OPAC, the main vehicle for upskilling country teams). However, only 29 women and 18 men completed this training compared to over 200 on other OPAC trainings.¹⁸⁴ Participants of the mainstreaming module were also mainly staff (90 per cent), with roughly 50/50 representation from HQ/decentralised offices. The decision to make this training module accessible to everyone from IFAD's website (since June 2023) is a positive move towards reaching project staff and local consultants. However, it is not yet available in French, Spanish or Arabic restricting its outreach.
- c. Gender guidance and tools**
148. **Over the years, IFAD has produced a steady flow of guidance documents and tools on GEWE, but they are not entirely coherent and have not been compiled in a comprehensive gender toolkit¹⁸⁵.** PMD staff and consultants and PMU staff report knowing where to find such resources and information (75 per cent for PMD, 73 per cent for PMU). From 2019-2021 particular focus was placed on creating frameworks and guidance on the interlinkages between mainstreaming themes¹⁸⁶. IFAD also developed guidance on approaches to address the root causes of gender inequality, especially from 2019. Results from the TE e-survey reveal that a substantial proportion of PMD staff and consultants (87 per cent) reported having a good understanding of the distinction between "gender mainstreaming" and "gender-transformative" projects, while this proportion was lower from PMU staff (64 per cent). However, country case studies revealed IFAD, and especially PMU staff, often misunderstood what GT entails.
149. A glossary of gender issues was published in 2017 to help enable consistency of terminology used in relation to gender issues in Arabic, English, French and Spanish. A second edition with new and updated terms and definitions was published in 2021. Indeed, the majority of PMD staff and consultants (82 per cent) reported that there is consistency and conceptual clarity in the use of gender terms across IFAD. Notwithstanding these efforts, the majority of both PMD staff (67 per cent) and consultants and PMU staff (63 per cent) reported issues regarding the

¹⁸³ It is available to all IFAD staff and non-staff and aims to familiarise participants with the interrelated mainstreaming themes of environment and climate, gender, nutrition and youth in IFAD projects.

¹⁸⁴ OPAC trainings with over 200 participants included IFAD12 business model overview, Updated SECAP (2021 edition), Financial terms and products. Data from OPAC statistics on the intranet (November 2022-October 2023).

¹⁸⁵ The 2017 poverty targeting, gender and empowerment toolkit was followed by eight additional pieces of guidance which do not totally align, which can create confusion (see Annex XX).

¹⁸⁶ This was achieved through the action plans for each of the four mainstreaming themes, the enhanced 2021 SECAP, the 2019 revised operational guidelines on targeting, and the 2019 Framework for mainstreaming themes.

translation of key gender-related concepts to other languages.¹⁸⁷ Annex XX summarizes the key guidance and publications during the evaluation period.

C. Financial resources

150. **IFAD has not established a target percent of funds to be spent on gender-related work.** To “meet” requirements of UNSWAP performance indicator on financial resource allocation, similar to FAO, IFAD should ensure the integration of gender equality into budgetary decisions. The 2022 IFAD UNSWAP report states that given IFAD's hybrid nature as a bank and a UN agency, research is ongoing to determine the proper benchmark. Further analysis of IFAD's financial resource tracking systems is in Annex XXI.
151. **Since 2012, financial resources for gender-related work have not seen an increase in the administrative budget, but there has been an increase in the programme of loans.** Staff time/costs on gender-related work across the organization have varied between 7 and 10 per cent over time. The proportion of loan programmes (in terms of loan value) at design with ratings of 4+ increased from 77 per cent in 2012 to 91 per cent in 2021. The analysis also indicates that the proportion of loan programmes (in terms of loan value) at design with ratings of 5+ increased from 8 per cent in 2012 to 26 per cent in 2021.¹⁸⁸ Grants show a slightly decreasing trend in ratings of 4+ and ratings of 6 from 2015 to 2021. However, all these results need to be interpreted with caution given the limitations in methodology. See annex XXI for more details and graphs.
152. IFAD lacks a comprehensive understanding of the actual costs associated with promoting GEWE in projects (as identified in the 2010 CLE). One reason is that gender is rightly mainstreamed across project components and activities making it hard to identify the proportion of funds spent on gender-related work. Although two thirds of PMU respondents to the TE e-survey agreed that financial resources are clearly allocated to activities that are gender-specific, the TE finds that information about budget and actual costs for gender are scant and unsystematic.
153. **Overall financial resources in the gender and social inclusion team have increased since 2018, primarily through the mobilisation of supplementary funds.** Figures in Annex XXI show the increase in the team's annual staff and non-staff budget from 2018 to 2023.¹⁸⁹ The annual total staff budget increased by 65 per cent due to an increase in the core staff budget (with the recruitment of new staff).¹⁹⁰ The annual total non-staff budget from supplementary funds, core non-staff budget and supplementary fund management fees increased by 265 per cent.¹⁹¹ This was due to the injection of funds by the GTM and phase two of the JP RWEE, and other sources.¹⁹² These funds mostly cover the core activities of supplementary fund programmes and a minority of headquarter-based consultants. However, the oversight and management of these supplementary funds have also demanded a substantial proportion of team staff time.
154. **The core non-staff budget has decreased over time from US\$297,000 in 2018 to US\$17,500 in 2022 and US\$62,688 in 2023.**¹⁹³ Following a change in the allocation of **management fees** in IFAD, the gender and social inclusion team did not receive any such fees in 2023. Interviews confirmed the uncertainty in the availability of these funds for the team to use for various tasks including the Gender Awards and, critically, for consultants to cover core activities. Annex XXI

¹⁸⁷ It is not clear whether this refers to official IFAD languages or local languages.

¹⁸⁸ Percentages come from IFAD's 2013 and 2022 RIDE reports, respectively.

¹⁸⁹ Gender and social inclusion team budget data for the period 2012 to 2017 were not provided to the evaluation team.

¹⁹⁰ Annual **staff budget** (core staff, JPO staff, GTM staff) increased from USD415,000 in 2018 to USD686,000 in 2023.

¹⁹¹ Annual **non-staff budget** (core non-staff, management fees, supplementary funds) increased from USD976,000 in 2018 to USD3,373,000 in 2023.

¹⁹² Supplementary funds since 2018 have come from the JP RWEE phase 1 (2018-2022), EU JP GTA (2019-present), ASAP2 for GALS (2019,2021), GTM (2021 - present), JP RWEE phase 2 (2022-present).

¹⁹³ Data from IFAD 2018 UNSWAP report and budget data given to the evaluation team.

shows the figures with changes to the distribution of non-staff budget allocated to the team over time.

D. Accountability, monitoring, reporting and incentives

155. **The 2012 Policy on GEWE established a clear accountability framework and reporting mechanisms, which became less clear in the 2019 action plan.** The policy included an implementation plan and an accountability framework at the divisional level. It also stipulated how performance against the indicators would be reported on annually to the Executive Board through the RIDE (now RIME). RIDE reporting has been upheld each year since 2012 (See Annex XXII). The 2019 gender action plan did not specify divisional responsibilities and did not explicitly show how the outcomes/outputs are aligned with the UNSWAP performance indicators. Gender has not been identified as a key risk at IFAD needing an audit,¹⁹⁴ but IFAD's office of audit and oversight includes a question on gender balance in staff surveys in offices of PMUs,¹⁹⁵ which are reported for internal use only.¹⁹⁶ Investigations are also conducted into allegations of sexual harassment or sexual exploitation and abuse and progress on IFAD's investigation activities are included on IFAD's website.
156. **Throughout the evaluation period, IFAD's Results Management Framework (RMF) emphasised particular gender indicators for corporate reporting purposes and accountability.** Gender is not explicitly included in the highest level of the RMF (tier I). IFAD's contribution is focused on SDG1 and SDG2, without mentioning SDG5 (or the previous MDG3). For tier II (development impact and results), all indicators related to persons have to be disaggregated by sex- and age.¹⁹⁷ The percentage of completed projects rated 4+ for gender has been the key indicator monitored since 2013. The RMF 2019-2021 introduced new indicators: the percentage of PCRs rated 5+ for GEWE and the percentage of women reporting minimum dietary diversity (SDG 2.2).¹⁹⁸ Gender targets have progressively been incorporated into replenishment commitments (see Annex VI). IFAD12 did not include any additional commitment on gender but increased the proportion of new designs validated as GT from 25% in IFAD11 to 35%. This target was maintained in IFAD13.
157. **Reporting against UNSWAP has helped move the gender agenda at IFAD forward, but has not entailed internal discussions for improvement.** IFAD has been reporting to the UN entities common performance standards for the gender-related work (UNSWAP) since 2012. The range of areas covered has broadened the scope of IFAD's work on GEWE and communicated in a concrete manner that responsibility for GEWE should be institution-wide, not just limited to the gender and social inclusion team. Different units in IFAD are responsible for reporting on specific UNSWAP indicators. The Office of the President and Vice-President communicates the annual result report to UN Women and responds to the UN Women on how these will be addressed. However, no meetings have been organized within IFAD to discuss UNSWAP results and prepare a coherent internal plan to improve performance across the UNSWAP indicators. IFAD has not yet met

¹⁹⁴ UNSWAP advocates a targeted audit engagement every five years, as FAO, WFP and UNDP have done. For instance, since 2019, WFP audits include a section on the "level of gender maturity" of the business area/country office audited.

¹⁹⁵ One out of 16 survey questions: "do you feel you are treated fairly regardless of diversity aspects, including your gender, race, ethnicity, nationality, abilities and disabilities, staff position (national/international), contract modality and so forth? Please provide details."

¹⁹⁶ Verified by the evaluation through review of internal audit reports 2018-2023.

¹⁹⁷ For instance, male/female ratios in the numbers of trained people in crop/livestock production, or the absolute numbers of savers and active borrowers for the rural financial services promoted by IFAD-supported projects. Since RMF 2016-2018, a new indicator concerning the number of poor small household members supported in coping with the effects of climate change is expected to be disaggregated by sex and age (page 17 of RMF 2019-2021).

¹⁹⁸ IFAD13 has included an **impact-level indicator on women's empowerment** in the RMF for the first time, associated to SDG 5.6. The target for this replenishment period reads as "61 million people living in households where women have improved economic participation, as measured by **decision-making over income resources** (10 per cent or more)". This will be calculated through impact assessments and reported in 2028 (IFAD13/4/R.2, December 2023).

two UNSWAP performance indicators during the TE GEWE period. These concern "Financial Resource Allocation" (only met in 2018) and "Equal representation of women" (see Annex XXII).

158. **The quality of the accountability framework for gender parity and diversity improved with the introduction of the 2021 Strategy on DEI, but it is limited to HRD.** Two indicators have been used in IFAD's strategic instruments to measure performance on gender parity and diversity in the organization.¹⁹⁹ They have clear targets and lines of responsibility and have been reported on each year in the RIDE. HRD's 5R action plans (2017-2021, 2022-2026) provided various activities to achieve gender parity and progress towards them was reported to some extent in the RIDE and UNSWAP and then more systematically since 2021 in annual reports to the Board. The 2021 Strategy on DEI enlarged the scope of indicators bringing them more in line with the UNSWAP requirements and added new indicators to measure diversity.²⁰⁰ However, gender parity is not explicitly part of divisional objectives, besides the human resources division (HRD).
159. **There is no clear indication that gender has been systematically and strategically discussed in any senior management committee.** The high-level gender task force suggested in the policy for corporate guidance and accountability was not implemented. The 2016 mid-term review of the policy refers to the role of the Operations Management Committee for corporate oversight and accountability.²⁰¹ However, discussions on gender-related strategic issues in this committee was not confirmed by TE interviews. Interviews with IFAD senior management highlighted the role of the Programme Management Committee, along with the internal IT-based dashboard used to track project performance on GEWE.²⁰² IFAD does not have any high-level committee on gender to ensure implementation of all action areas in the policy and action plan²⁰³, as per some comparator organizations. For example, the Gender Steering and Implementation Committee at UNDP, chaired by the Administrator, sets the policy and monitors implementation of the gender strategy.
160. **The staff performance evaluation system is not systematically used to incentivise the promotion of gender equality and gender parity.** Three out of ten organizational competencies in the IFAD competency framework refer to the promotion of gender equality at work, providing some guidance to include it in staff performance planning and assessment. However, the inclusion of gender-related competencies in staff performance evaluations is not monitored, so it is not possible to gauge the extent of usage by staff (men and women). Only 42 percent of PMD staff who answered the TE e- survey said that GEWE objectives and results are reflected in their performance evaluation and are discussed with their supervisors (19 per cent responded "do not know" and were not included in the figures above). According to interviews, a minority of divisional Gender focal points systematically include their gender responsibilities in their performance evaluations or dedicate the expected 20 per cent of their time to this function, as expected in

¹⁹⁹ Indicators 4.1 Number of **women employed by IFAD at grade P5 or above** and 4.2 **Scores on gender-related staff survey questions** by both women and men (part of the fourth action area of the policy).

²⁰⁰ Women representation at senior level (percentage of women at grade P-5 and above); Gender parity in all grades (percentage of male and female staff in all grades); Capacity assessment and development – percentage of supervisors trained in mandatory training on gender bias; Increased representation of List B & C countries (International Professional staff); Staff engagement index (Global Staff Survey) with DEI-specific indicators.

²⁰¹ The OMC is responsible for overseeing the implementation and delivery of IFAD's corporate policies, strategies, programme of work and budget. It is also responsible for identifying and taking decisions on routine operational matters. Held once a week. Participants – VP, AVPs, LEG, chief of staff, Secretary, Director HRD, CSD, Risk. Directors of ECG, OPR, regional divisions and others can attend as observers.

²⁰² The PMC brings together managers and senior managers of PMD, SKD and FMD as co-owners of the planning and management of regional, country programme and project portfolios. It aims to ensure greater coordination and cooperation among operational stakeholders to ultimately improve the management and results of IFAD's portfolio.

²⁰³ For instance, the second policy action area and the third (IFAD as a catalyst for advocacy, partnerships and knowledge management; and Capacity building of implementing partners and government institutions) have been largely overlooked in terms of the resources required and results achieved.

the 2022 5R Action Plan. Moreover, few of them cited the promotion of gender parity as a task.

161. **Monitoring the ongoing portfolio gender rating trends and projections is the main “incentive” to work on gender at operational level.** The gender ratings of the ongoing portfolio are regularly scrutinized at regional level. However, they are geared towards compliance. According to all interviewees and dashboards reviewed, priority is given to supporting projects with weaker performance in GEWE close to completion. An additional soft incentive highly appreciated by interviewees during case studies and TE e-survey respondents is the gender awards to recognize the GEWE effort and/or achievements of selected projects.²⁰⁴ Since 2013, every two years a committee selects a project in each of IFADs five regions that has taken an innovative, transformative approach to addressing GEWE.

E. Internal processes to support operations

162. **The budget and time allocated for project design decreased at a time when there was an increase in compliance on mainstreaming themes.** Average design budgets decreased from USD177,000 during IFAD9 (2013-2015) to USD144,000 during IFAD11 (2019-2021) and the time allocated reduced from 17 months in 2016 to 8 months since 2019.²⁰⁵ The review of nine of the project designs approved before 2019 covered in the country case studies showed that less than half involved a gender expert on mission. More recently, the total design budget increased from USD4.8 million in 2022 to USD8.6 million in 2023.²⁰⁶ Responses to the TE E-survey in 2023 showed that 34 per cent of PMD staff disagreed that there were sufficient financial resources to hire gender experts for project design missions.
163. **Interviews for the TE warned about the difficulties for some social inclusion professionals to provide good quality technical inputs on gender in project delivery teams.** Currently, one staff or consultant from the social inclusion cluster is responsible for overseeing the technical quality of all social inclusion themes in a project design. For example, a staff or consultant expert in nutrition or youth is also responsible for ensuring the technical quality of gender and targeting. Interviews from within and outside ECG revealed that the assumption that any social inclusion professional can adequately cover all social inclusion themes does not often hold true, affecting the quality of technical inputs. Additionally, interviews highlight that the participation of gender and social inclusion staff/consultants as PDT members is inconsistent, sometimes getting involved later in the design process or not engaged in field missions and drafting reports.²⁰⁷
164. **The revised process to ensure quality, evaluability and compliance during project design reviews, gives significantly less attention to GEWE.** The previous quality enhancement process involved a gender and targeting expert (staff or consultant) to review the technical quality of these matters in each project design. Reviews of technical quality through the present design review meeting (DRM) are not informed by gender and targeting experts.²⁰⁸ Following the endorsement of the IFAD Development Effectiveness Framework in 2016, a development effectiveness matrix (DEM) was created and then updated in 2020 to DEM+ and once again in June 2023 to improve workflow efficiency (“revised DEM+”). In DEM+, there was a specific rating for GEWE and an explanation for the

²⁰⁴ 89 per cent of PMD staff and 93 per cent of PMU staff agreed that these awards boosted motivation among IFAD and project management staff to improve GEWE results. This was also corroborated by PMU staff during various case studies, who found the award helped them to get additional attention to gender from national authorities and other partners.

²⁰⁵ IOE CLE decentralization (2023). This trend is also captured in the 2024 MOPAN assessment report on IFAD.

²⁰⁶ MOPAN assessment report IFAD, 2024

²⁰⁷ It is noted that staff turnover and subsequent changes to PDT assignments can occasionally mean the Country Director and Project Technical Lead are not aware of who is the social inclusion PDT member.

²⁰⁸ Unless the peer reviewer from SKD is from the gender and social inclusion team.

rating, guided by seven questions. The revised DEM+ does not have a GEWE rating, just a review of the engagement of vulnerable groups “including women”.

165. **The technical quality of GEWE assessments in supervision mission reports exhibits significant variability, a situation exacerbated by budget reductions.** Technical quality depends strongly on whether a gender and social inclusion expert is present. In the absence of an expert, there are examples of gender being assessed by the CPO, M&E specialist or a general services staff member. The situation is not helped by the decrease in the average budget for supervision by 28 per cent, from USD29,000 in 2016 to USD21,000 in 2019.²⁰⁹ The TE E-survey showed that 55 per cent of PMD respondents agreed that there are insufficient financial resources to hire gender experts to go on supervision missions.

F. Gender and diversity balance and organizational culture

166. Gender and diversity balance in IFAD’s gender policy is based on the recognition that they are important for enhancing organizational effectiveness. Having internal measures to promote gender and diversity balance signals engagement with United Nations values and makes IFAD more credible as an advocate for GEWE in its relations with governments and other partners. The policy also recognises how gender and diversity balance and organizational culture are inextricably linked and mutually reinforcing.
167. Gender parity at all levels in the UN is a commitment more than two decades old.²¹⁰ Notwithstanding numerous UN policies, reports and recommendations to further this goal over time, implementation in UN agencies has reportedly been hampered by a lack of sustained political will and accountability, absence of accompanying measures and enabling conditions for reform, as well as resistance from some stakeholders.²¹¹ IFAD’s implementation of the 5R action plan and DEI strategy is limited to the availability of existing HRD financial resources. A consultant was hired in April 2023 to support HRD with DEI strategic initiatives and UNSWAP reporting, financed from the divisional budget. Over the last few years, interviews indicate that gender parity per se has not been a high priority in IFAD, although efforts are evident to further diversity, equity and inclusion in general.
- a. Gender balance among staff and consultants**
168. **From 2016 to 2023 women have consistently represented just over half of staff.** Their representation among national professional staff and in P5 posts and above has improved, while they are persistently overrepresented among general service staff.²¹² A more detailed breakdown by all staff categories over time can be found in Annex XXIII. IFAD attained its targets in 2021 and 2022 that women account for 35 per cent and 40 per cent of P5 posts and above, respectively. Progress was initially slow until 2019 when there was a step change. In 2023, there is gender parity among national professional staff (for the first time) and among junior to mid-level international professional staff. The evaluation did not find any evidence of efforts to improve gender parity in the GS categories by increasing men’s representation.
169. **IFAD’s gender balance among staff is on a par with other UN agencies but below UNSWAP requirements.** In 2019, the percentage of women in IFAD in the professional categories was 45 per cent, on a par with twenty other UN agencies,

²⁰⁹ According to 2024 MOPAN assessment on IFAD, the total budget for supervision increased from US\$13.4 million in 2022 to US\$14.9 million in 2023

²¹⁰ Gender parity refers to the equal representation of men and women.

²¹¹ 2017 UN System-Wide Strategy on Gender Parity, issued by the Secretary General

²¹² This is an improvement compared to the findings of the 2010 CLE on gender that found that the ratio of women to men in the organization was traditional, with many women in support staff positions and few in leadership functions. There was a high proportion of women in the more junior Professional level but numbers petered out in the higher levels.

while others had 50 per cent or more women.²¹³ In 2023, the percentage of women in IFAD stands at 49 percent. However, IFAD still does not have a plan to achieve the equal representation of women nor achieved parity in all categories and levels, as per UNSWAP requirements. Decentralisation has also brought additional challenges to achieving gender parity, see below.

170. **Women are less represented in staff categories with decision-making responsibilities in decentralised offices.** Women employed in decentralised offices increased from 38 per cent in 2016 to 49 percent in 2022.²¹⁴ However, in the first quarter of 2023 the percentage of women international professional staff is lower in decentralised offices (42 per cent) than in headquarters or liaison offices (52 per cent).²¹⁵ The proportion of female Country Directors has been low since 2016 (ranging from 20 to 30 per cent). In 2023, it increased to 36 percent in ESA and to 50 per cent in WCA, but is just 9 per cent in APR. Women representation is even lower among P5 posts and above (women represent 29 percent in decentralised offices versus 48 at HQ/liaison offices).²¹⁶ For instance, among the heads of decentralised offices in 2023, women make up 2 out of 12 incumbents.
171. **IFAD has made efforts to facilitate a gender-responsive recruitment process and support the career development of men and women, but staff perception of these processes worsened from 2016 to 2022.** An internal study in 2017 found that gender had an effect on being in a P5 post and on career advancements, all other factors controlled for, and that the more independent the recruitment process, the better for women's career advancement.²¹⁷ Annex XXIII identifies the subsequent initiatives made by IFAD in recruitment and support for career development. Global staff survey results from 2016 to 2022 show that perceptions of the fairness and rigour of recruitment at IFAD worsened among men and remained low among women.²¹⁸ In terms of adequacy of opportunities to advance their career in IFAD, perceptions also worsened and more so among women than men.²¹⁹
172. **Informal networks for peer support related to IFAD serve as valuable tools for the career development of women and young professionals.** Female staff in IFAD founded the Women's Informal Network in 2016 to promote inspirational women's leadership and managerial capacities, see box below. Young women and men can also obtain support, learn from senior staff and expand their contacts through the IFAD Youth Network.²²⁰

²¹³ Professional positions from P1 to P5, directors and other senior management. UN-Women (82.4), United Nations System Staff College (56.5), UNAIDS (53.6), UNESCO (51.9), PAHO (50.7), UNFPA (50.5), UNICEF (50.2). Report of the Secretary General, July 2021, Improvement in the status of women in the United Nations system

²¹⁴ IOE 2022 Corporate level evaluation on decentralisation.

²¹⁵ IFAD liaison offices (with 1-4 staff each) are in New York, Washington, D.C., Riyadh, and Yokohama.

²¹⁶ IFAD strategy on DEI update, May 2023, EB 2023/138/R.12. **International professional staff** refers to internationally recruited staff on fixed-term, continuing and indefinite appointment in professional and higher categories (including directors, Associate Vice-Presidents and the Vice-President), excluding Junior Professional Officers.

²¹⁷ Internal document. Analysing the representation of women among IFAD senior staff; a development effectiveness study by RIA in cooperation with Corporate Services Department, 2017

²¹⁸ The percentage of both men and women who disagreed with the perception that **recruitment at IFAD is rigorous and fair** increased from approximately 30 to 40 per cent between 2016 and 2022. Agreements with the statement decreased for men (from 40% in 2016 to 33% in 2022) and remained the same for women (26% in 2016 and 28% in 2022). The proportion of women that answered neutrally decreased from 45% to 30% over the same time period, which translated into more disagreements to the statement.

²¹⁹ The proportion of men and women that disagreed that they have adequate opportunities to advance their career in IFAD increased from 2016 to 2022 (from 32 to 39 per cent for men and from 37 to 46 per cent for women). Furthermore, the 30 per cent of men and 21 per cent of women that agreed with the statement in 2022 was markedly lower than the external benchmark of 51 per cent.

²²⁰ The IFAD Youth Network (IYN) is a community for young development practitioners aimed at providing a support network for young and young at heart employees in IFAD. The network focuses on increasing young employees' involvement, innovating and energizing at IFAD, and providing career enrichment opportunities.

Box 23**Women's Informal Network (WIN)**

WIN is an informal professional network for women (staff and consultants) working in international development with currently over 700 members globally from more than 50 organizations (UN, multilateral development banks, Government, NGOs). Out of the 723 women professionals in 2023, members mainly come from FAO (31 per cent), IFAD (27 per cent) and WFP (7 per cent). Interviews and social media confirm that it has enabled these members to interact, learn from each other and provide mutual support through regular events that cover personal and professional issues affecting their career development. Besides events, there have also been a mentoring programme, coaching sessions, and a speaker series called "Women Leaders Forum" in which women leaders shared their views and expertise with WIN members in the Rome-based agencies of the UN. New IFAD staff are encouraged to join WIN during the mandatory corporate induction series.

Source: WIN Facebook page <https://www.facebook.com/profile.php?id=100066692330741> and YouTube channel <https://www.youtube.com/@womensinformalnetworkglobo682/videos>. WIN data provided by Coordinator.

173. **The overall gender balance among consultants has improved over time, although women constitute a low proportion in four divisions.** IFAD's handbook on consultants and other persons hired on a non-staff contract have been updated since the 2010 CLE to clarify that contracting managers should give primary consideration to technical competence when hiring consultants but also take into account the criteria of equitable geographical distribution and gender balance. Analysis of human resources data on IFAD consultants shows that the overall proportion of women marginally increased from 39 per cent in 2016 to 44 per cent in 2023. By division, the gender balance among consultants is reasonable in most divisions (with women representing between 35 per cent and 65 per cent each year). Gender parity among consultants in ICT, IOE, LAC, NEN and QAG has improved over time with women's representation increasing to 50 to 60 per cent. The proportion of women consultants remained relatively low (2016-2023) at around 30 per cent in APR, ESA and WCA, and has recently decreased in FMD.²²¹
174. **There is a persistent underrepresentation of women among field-based consultants.** They made up 26 per cent of field-based consultants in 2016 and 34 per cent in 2023. This is markedly lower than women consultants in HQ (60 to 64 per cent) and home-based (40 to 45 per cent) over the same time period. Interviewees also highlighted the concern of male dominated missions, which can sometimes impact the ability of female consultants working on social inclusion to be actively heard and acknowledged. Some interviewees and a female consultant supporting the LAC regional office who responded the TE e-survey raised issues faced in decentralised offices²²².
- b. Diversity**
175. **The staff perception of whether people in IFAD are treated equally regardless of their differences deteriorated between 2018 and 2022, especially among women.**²²³ In 2018, 65 per cent of men and 61 per cent of women agreed that people were treated equally. By 2022, this had decreased to 58 per cent of men and 42 per cent of women and the average of 49 per cent was starkly lower than the external benchmark of 70 per cent. Recent modifications to IFAD's recruitment process guidelines and human resources processes are noted

²²¹ Women's average annual representation among consultants from 2016 to 2022 is 26 per cent (APR), 32 per cent (ESA), 30 per cent (WCA). In 2023, women's representation among consultants in FMD was 29 per cent.

²²² "As a woman and working mother, I believe sometimes we are mostly aware about gender issues regarding IFAD operations but fail to do as much as possible when it comes to considering gender issues regarding our daily workload and schedule. For instance, it is too much of a mental and physical pressure when the workload and schedule require skipping meals or inadequate rest, while having to take many more pre and post- office hours parenting, being already physically stretched and sleep deprived."

²²³ The staff survey question was "People here are treated equally irrespective of gender, race, ethnicity, nationality, age, language, sexual orientation, abilities and disabilities, culture, religion, profession, education, marital status, workplace experience, role, staff position (national/international) and contract modality".

(See Annex XXIII). Usefully, data on different staff and non-staff categories (but not consultants) are disaggregated by gender, office location (HQ & liaison office or decentralized office), and grade level.²²⁴ Evidence of other efforts to promote DEI since 2021 are identified in box below.

Box 24

IFAD's recent efforts to promote Diversity Equity and Inclusion (DEI)

The nomination of 14 DEI advocates with different roles, ages, nationalities and locations. They have been trained on awareness-raising and sensitization, and internal and external coordination and collaboration. However, this has not been linked to the work of gender focal points, adding to the uncertainty of what the GFP role entails;

DEI sessions conducted at divisional meetings and staff retreats and held at the corporate level ("talks with experts") to increase awareness and generate internal discussion;

The launch of an internship programme for Indigenous Peoples in LAC division to be piloted in each IFAD Country Office. A first cohort of interns were due to start in Q3 2023;

On gender identities and expressions: [pronoun preference](#) in email signature, Zoom meetings and on Microsoft Teams; online training course on LGTBQ+ awareness and allyship in the workplace;

The ongoing implementation of IFAD's disability inclusion strategy 2022-2027. It involves updating HR procedures to facilitate the recruitment and retention of persons with disabilities as well as staff with dependents with disabilities. It has also seen the creation of "SPARK", a help desk to provide technical support for the design and implementation of disability-inclusive rural development projects.

Source: IFAD strategy on DEI update EB 2023/138/R.12; interviews.

c. Organizational culture²²⁵

176. **There is a high level of motivation among staff and consultants and government implementers to promote GEWE in operations and the workforce.** Almost all PMD respondents (96 per cent) and PMU respondents (94 per cent) in the TE e-survey agreed that they were motivated to work on GEWE. This is backed up by the perception that their managers promote gender equality internally at IFAD (90 per cent) and their supervisors demonstrate commitment to achieve gender equality objectives in operations (90 per cent), with no difference in answers between men and women. The high level of motivation to promote GEWE was also communicated throughout TE interviews by men and women from different divisions. From 2018 to 2023 the gender balance in the gender and social inclusion team improved from having no men to one-third men.²²⁶ This was a positive step to strengthen the message in-house, in the field and to external partners that GEWE is an important and topical issue that concerns everyone.
177. **IFAD senior management is perceived to "talk the talk" on gender mainstreaming but some staff, particularly women, do not think they "walk the talk", which diminishes credibility.** Since 2018, IFAD has implemented a policy to prevent and respond to Sexual Harassment (SH), Sexual Exploitation and Abuse (SEA) and an action plan on hate speech to help promote a conducive workplace culture.²²⁷ SH/SEA focal points have also been appointed across divisions and offices. Most of PMD respondents (91 per cent) to the TE e-

²²⁴ Staff are reported in terms of all workforce, full-time, international professional, national professional, JPOs, GS, short-term, and in response to requests from the EB also Special Programme Officers, staff on-loan and interns.

²²⁵ Understood as a set of deeply rooted beliefs, values and norms (including traditions, structure of authority and routines) in force within the institution; and a pattern of shared basic assumptions internalized by the institution. UN Women, 2022, UNSWAP 2.0 technical guidance on performance indicator 13 Organizational culture.

²²⁶ In 2016 6 out of 6 professional staff and long-term consultants were women; in 2019 2 out of 6 were men.

²²⁷ IFAD has implemented SH/SEA action plans (2018–2019, 2020–2021, 2022–2023) and provided mandatory training to the IFAD workforce and implementing partners. The obligation to abide by the IFAD SH/SEA policy has also been extended to borrowers/recipients of IFAD funding. Update on IFAD's approach to address the United Nations Strategy to Prevent and Respond to Sexual Harassment, Sexual Exploitation and Abuse, EB 2023/OR/5, August 2023. Note that this thematic evaluation does not aim to evaluate the implementation of this policy, see the 2024 MOPAN assessment of IFAD for more analysis.

survey perceive a strong commitment from IFAD senior managers towards promoting GEWE in operations, although fewer women (86 percent) agreed to the statement than men (95 percent).²²⁸ TE interviews with staff from across the Fund also showed that women are more likely to question senior management's practical measures and incentives to sufficiently mainstream gender in operations and the workforce, compared to men. In addition, a smaller proportion of women in 2022 agreed that IFAD promotes a culture of gender balance (65 per cent) compared to men (79 per cent). With regards to women in leadership, the TE e-survey for PMD staff and consultants shows that a smaller proportion of women (79 per cent) than men (96 per cent) perceive that IFAD's organizational culture values women in leadership.

178. **IFAD's periodical surveys to monitor the engagement level of its staff and workplace culture lack an intersectional lens.** Over the evaluation period, IFAD has conducted regular global staff surveys on staff engagement (2014, 2016, 2018, 2019, 2022) and workplace culture (2019, 2022).²²⁹ However, the final reports lack an intersectional approach to understand the interplay of gender with other variables (age, HQ/field, staff category, supervisor/not supervisor). Such analysis was done in 2014 by the gender and social inclusion team revealing the least satisfied staff to be male general service staff.
179. **Despite some measures in recent years to improve work-life balance, many staff, especially women, continue to perceive them as inadequate.** Analysis of global staff surveys from 2016 to 2022 shows a clear deterioration in men's and specifically women's responses regarding senior management actively supporting a work-life balance.²³⁰ Although work-life balance was an issue for all, perceptions were worse among women. This was also echoed by a respondent to the TE e-survey.²³¹ Since the COVID-19 pandemic, IFAD has augmented its flexible working arrangements. Interviews showed that staff were widely appreciative of the ability to telework in their duty station, affording them greater flexibility to manage personal, family and professional commitments.²³² Results of IFAD's 2021 teleworking survey showed that women generally preferred more days teleworking compared to men.²³³ However more flexible working arrangements has also led to the closure of IFAD's childcare facility in headquarters due to insufficient demand. A recent positive step taken by IFAD, and too soon to be reflected in global staff surveys, is the introduction of unified parental leave in 2023. Recognising the important role of each caregiver in raising a child, it improves the leave entitlement of different types of parents (birth, non-birth, adopting, and surrogate). See Annex XXIII for an assessment of IFAD's measures to improve work-life balance.
180. **IFAD's relocation of staff has, up to the present, not offered adequate support to families, with implications for gender equality.** The provision of childcare facilities in IFAD decentralised offices is not congruent with the number and size of these offices. However, there is scope to systematically provide

²²⁸ The difference between male and female respondents was statistically significant at 5 per cent.

²²⁹ Topics covered span: career and staff development; decentralisation; ethics and diversity; knowledge and information sharing; leadership, performance management, recognition and reward; safety and security; staff engagement index; teamwork; work effectiveness, efficiency and innovation; and work-life balance.

²³⁰ The percentage of men and women responding positively from 2016 to 2022 changed from 45 to 33 and from 50 to 26, respectively. Interviews highlighted a problem related to high workload.

²³¹ "... the organizational culture in IFAD leads to giving opportunities mostly to those women who can better adapt to a 24/7 work mindset, who choose/are able to prioritize work over any other personal matter. Most of IFAD staff tend to cover many more demands than originally planned (...) adding pressure on existing staff, which is especially negative (for) women supporting their families." (Female, LAC, 2 to 4 years of experience)

²³² Teleworking in the duty station refers to being within commuting distance (defined as 150 km or 1.5 hours). In addition, there is an exceptional teleworking provision that allows requests of up to 10 consecutive working days once in a month, subject to an overall ceiling of 35 cumulative working days per year.

²³³ This is in line with the 2021 research into American women's century long journey towards equity by Claudia Goldin, Nobel Laureate. She identified how the growth of remote and flexible work may be the pandemic's silver lining (for women's advancement at work), particularly in professions that demand long hours and weekend work.

information about childcare options to ease the transfer of international staff²³⁴. In addition, IFAD does not support spousal employment for international staff. Other organizations are supporting staff relocation and promote gender equality. For instance, the World Bank hires companies to find the right schools and housing for reallocated staff to headquarters and to support spousal employment and spouses' integration into the duty station.²³⁵

Key points about the Organizational fit-for -purpose to deliver on gender-related commitments (Section VI)

- Corporate documents with reference to gender have paid less attention over time to how **key components of IFAD's human resources** would contribute to fulfilling GEWE commitments. In the meantime, the increase in staffing in the gender and social inclusion team has not kept pace with increased workloads. The work of social inclusion and gender analysts serving IFAD regions is valued in operations, but their contributions can be limited due to their lack of seniority relative to other regional technical staff. Gender focal points in IFAD divisions play a relatively minor role in gender-related work;
- Basic **training on gender** for staff and consultants has been systematically implemented by the Human Resources division, but half of those responding to the TE e-survey said it was not sufficient. With the resources to hand, the gender and social inclusion team has conducted some training for staff, consultants and PMUs through regional gender clinics and also during project start-up. However, half of the PMU respondents to the TE e-survey think they have not received adequate training on GEWE to support operations;
- IFAD's tracking of **financial resources for gender-related work** shows that resources have increased through the programme of loans (between 7 and 10 per cent of the administrative budget). However, IFAD has not established a target percent of funds to be spent on gender-related work as per the UNSWAP requirement. Financial resources in the gender and social inclusion team have increased mainly through **supplementary funds** but this also brings additional work demands. In addition, other **sources of financing to cover core activities** are more uncertain;
- GEWE has not been systematically and strategically discussed in **senior management committees** nor has its promotion been well incentivised through the staff performance evaluation system. **Incentives** (compliance with replenishment targets) remain at the operational level;
- Some changes to **internal processes** to support operations have hindered the technical quality of interventions to promote GEWE. These concern budgets and time allocations for design and supervision, project delivery teams, and the quality assurance process;
- Overall, in terms of **gender parity in IFAD's workforce**, women have consistently represented just over half of staff. Female representation has improved among professional staff and in leadership roles. However, women are less represented among professional staff with decision-making responsibilities in decentralised offices and they remain over-represented in supporting roles as general service staff;
- IFAD has taken action to facilitate a better **gender and diversity balance** through internal processes, most notably recruitment. However, staff perceptions of some of these processes and their treatment have worsened over time;
- IFAD staff and consultants and government implementers are **highly motivated to promote GEWE**. However, staff perceive that senior management does not sufficiently "walk the talk". For example, many staff, especially women, continue to perceive measures to improve work-life balance as inadequate.

²³⁴ Only **Kenya, Vietnam, China** and **Panama** IFAD offices provided this information, as of mid-2023.

²³⁵ IOE CLE on IFAD's decentralization experience 2022; UN Women, 2021, Make Parity a Reality; Field-specific Enabling Environment Guide.

VII. Conclusions and recommendations

A. Conclusions

181. **IFAD's endorsement of gender mainstreaming and the more recent focus towards gender transformative approaches align well with the global discourse and adequately respond to IFAD's mandate and overall strategic framework.** Over the past decade, gender has become an explicit corporate priority. The approval of the gender policy in 2012 proposed that IFAD assesses the implications for rural women and men of any planned action, both within the organization and its interventions, as a strategy to reduce the gaps between men and women. This was complemented by targeted interventions to support rural women's empowerment. Building on work on gender transformative approaches that had been included into some IFAD field interventions since 2007, the 2019 GAP proposed to mainstream gender transformative approaches. This was put forward with the intention of more systematically addressing the root causes of gender inequalities, while keeping a gender mainstreaming focus in all activities. Such an approach corresponds with the latest focus in the literature on food security and gender, and the current IFAD strategic framework and compares favourably with the efforts of other comparator organizations. The partnership with the Rome-based agencies (and recently with the Gates Foundation) has been significant in shaping this agenda at the global level.
182. **Progress towards IFAD's gender strategic objectives during the evaluation period shows mixed results.** IFAD's concentration on enabling rural women and men to equally participate and benefit from profitable economic activities (first gender strategic objective) is a good entry point for the promotion of GEWE, particularly in contexts with high gender inequality. However, there is a lack of recent guidance on how to leverage rural finance for GEWE. In addition, evidence of the connection between the provision of technical training, income-generating activities and gender-inclusive value chain development and more gender-equal economic empowerment is limited. The TE found that methodologies such as *Cerrando Brecha*, piloted in Central America, are more useful to catalyse equal voice and influence (second objective) than the widespread use of women's quotas in the management committees of farmers' organizations supported by IFAD projects, which can lead to women's token participation. Yet, the cost and benefits of *Cerrando Brecha* have not been properly captured in M&E systems. IFAD distinguishes itself among international organizations by actively striving to achieve a fairer distribution of workload and benefits between rural men and women (third gender strategic objective). This is key for gender equality and women's social and economic empowerment, but currently its benefits through IFAD funding are assumed, and not assessed.
183. **Evidence indicates that implementing a combination of practices that address the root causes of gender inequality can contribute to transformative changes, particularly when tailored to specific implementation contexts.** For instance, the inclusion of Gender Action Learning system (GALS) in IFAD interventions is linked in some cases to more joint intra-household decision making, more equal sharing of domestic chores and preventing or reducing gender-based violence. Unfortunately, the replication of GALS in many IFAD projects has not been accompanied with an assessment of the resources required and the benefits derived at individual, household and community levels. Recent efforts through grants and loans involving strategic partners to build national capacities to implement GALS and other household methodologies and their upscale by some African countries are promising. Another notable example of a gender transformative practice was found when projects facilitated access to land and other natural resources for rural women, despite not directly tackling land tenure issues at the policy level.

184. **Throughout the last decade, IFAD's gender approach, guidance and procedures underwent numerous changes making it challenging to ensure their widespread adoption and understanding among all IFAD staff, consultants and government implementors.** Changes were vast and took place at different times. Gender-related guidance has not been compiled in a consolidated package easily available in all IFAD languages. For instance, the country case studies and interviews found confusion regarding IFAD efforts to enhance the measurement of (women's) empowerment or about what a gender transformative project means in practical terms. The provision of support from gender experts (staff and consultants) who are up to date with the latest changes in IFAD's approach and guidance to GEWE remains a challenge. A 2019 study on IFAD's workforce composition found a significant gap in technical expertise on cross-cutting themes and their interlinkages. Half of IFAD staff and consultants engaged in project operational activities who responded to the TE e-survey said they have not received adequate training.
185. **IFAD has not provided adequate capacity building to key implementing partners to ensure the effective promotion of GEWE in operations and to scale up GEWE results.** IFAD's traditional government counterparts (Ministries of Agriculture and Livestock) are not usually well capacitated to mainstream gender or address the underlying causes of gender inequality. Ad hoc attempts by IFAD to involve national institutions specialized in gender or women's issues to design and implement its GEWE interventions were noted. The effectiveness of this collaboration depends on the capacities of these national entities in charge of gender/women issues. Most of the gender capacity development offered by IFAD is channelled to the staff of the management units of the IFAD-funded project investments loans (PMU). Regional training and clinics and general orientation from IFAD gender experts during project start-up missions have been the main efforts to enhance government implementors' GEWE capacities. However, half of the more than 500+ PMU staff who responded the TE e-survey indicated that they did not receive adequate training on GEWE. The inclusion of IFAD gender experts in field missions has been inconsistent. However, their support is highly valued by 90% of IFAD operational staff, consultants and the PMU staff who responded the TE e-survey.
186. **COSOPs and GT PDRs are not currently leveraged for policy engagement on GEWE and for scaling up.** Planning for policy engagement on GEWE is one of the criteria for an IFAD project to be considered as gender transformative. However, the review of new GT-designs conducted by the TE confirmed the analysis conducted by management of 28 GT-validated PDRs. Most of them omit any reference to it or provide limited details. While gender transformative projects can contribute to changes in social norms at individual, household and community level, COSOPs are better placed to propose gradual actions over the long-term to address discriminatory laws and institutions. Associated guidance and training on policy engagement on GEWE has not yet been developed. *IFAD's approach to policy engagement* and the *Note on GEWE Scaling up* offer ideas in this regard, such as promoting dialogue across government agencies and piloting changes at the local administrative levels to inform national policy and legislation.
187. Country case studies and interviews revealed cases of misinterpretation of the concept of gender transformative change by representatives of country partner governments and some IFAD staff. Sometimes, inconsistent understanding is related to translation problems, but also to limited efforts to unpack and explain the concept and its benefits, including its operational implications. A clear understanding of gender transformative programming is necessary to link these efforts in the countries that IFAD serves to commitments expressed by States. Such commitments include the Sustainable Development Goals and supporting the

implementation of the Convention on the elimination of all forms of discrimination against women (CEDAW).

188. **Diversity in the workforce is improving, but IFAD has not done enough to promote gender parity beyond the headline figures.** There is an evident push for greater diversity among the workforce and gender parity in professional categories. Flexible working arrangements – widely recognised as crucial to promote gender equality - have improved through teleworking and helped both men and women staff members to find a better balance between their professional and personal lives. However, IFAD still lacks a monitored plan for the equal representation of women and men in all categories and levels as required across the UN. Resources to facilitate gender parity and diversity are restricted to the existing HRD budget. Yet decentralisation has brought additional challenges to achieving gender parity among international professional staff with decision-making power. The results of global staff surveys are not yet fully used to understand the perceptions of different types of staff and consultants.
189. **IFAD's accountability mechanism does not adequately equip IFAD to make strategic decisions related to GEWE and manage for development results.** IFAD does not yet fully reflect gender inequality as a risk for the effectiveness and sustainability of all IFAD interventions. Gender mainstreaming at all levels of the organization and gender parity and diversity in IFAD's workforce is paramount for organizational effectiveness and for the Fund's credibility as an advocate for GEWE in its relations with governments and partners. Senior management committees, which replaced de facto the high-level mechanism to oversee the policy implementation proposed in the 2012 gender policy, do not provide sufficient strategic guidance beyond the operational level. Other comparator organizations provide high-level oversight to monitor gender performance at strategic and operational levels. IFAD's 2021 Diversity, Equity and Inclusion (DEI) Strategy improved the accountability framework for gender parity and diversity in IFAD's workforce. However, there are few incentives for DEI, beyond the initiatives led by the human resources division.
190. **The successive increases in replenishment targets lacked a foundation in evidence from earlier experience.** The results management framework is mainly based on outreach numbers disaggregated by sex and gender ratings across the project cycle, rather than GEWE-related outcomes. This also cascades down to the reporting at the level of project investments. The justification of GEWE ratings in project supervision and completion reports is too often only based on outreach metrics, with little information about actual benefits and only assumed information about empowerment effects. Gender-related replenishment targets, as the main operational incentive, may have fuelled a compliance culture and overstretched staff. IFAD gender experts are devoting additional attention to investment projects getting lower gender ratings in the last years of implementation, to the detriment of catalysing and learning good practices from well-performing interventions that advance gender equality.
191. **The increase in human and financial resources for gender during the period has not kept pace with the rise in workload** since GEWE has been integrated with the other mainstreaming themes (youth, nutrition, along with indigenous peoples and persons with disabilities, where relevant), among other corporate tasks. Sporadic grants and supplementary funds have been helpful to cover important staff vacancies, but they also add additional work demands. Reliance on non-core budget introduces uncertainties for long-term planning. On a promising front, the strong motivation to engage on GEWE by IFAD's workforce and PMU staff, as indicated by responses to the TE e-survey and interviews, presents a favourable opportunity on which to build.

192. Given the context-dependent nature of gender issues in rural areas, IFAD's role is best understood as that of a catalyst for change. Most external interviewees for this TE and other recent assessments²³⁶ value IFAD efforts to promote gender equality and women empowerment in rural areas. The strategies and targets integrated into IFAD interventions to advance GEWE succeed when they receive strong support (and buy-in) from national partners and local stakeholders. Gender transformative approaches and their systematic inclusion in IFAD's programming should be recognised as an effective strategy for rural transformation, benefitting IFAD's target population as a whole. As social change evolves gradually, unpredictably, and in a not linear fashion, IFAD interventions achieve concrete outcomes when they support local communities and national governments in long-term planning, incorporating a blend of lending and non-lending support. The actionable recommendations provided below address key bottlenecks outlined in the report.

B. Recommendations

193. **Recommendation 1.** Focus the update of the **gender policy and the gender action plan** on strengthening IFAD's position to promote gender equality and women's empowerment (GEWE) in agricultural and rural development.
- Identify clearly how IFAD can add value by interpreting **what a gender transformative process means in practical terms** at community, project and policy level;
 - Include work with partners to develop pathways where IFAD could **contribute to catalysing changes** owned by national partners and local stakeholders that **address the root causes of gender inequality** in rural areas,
 - spell-out for IFAD interventions **how gender intersects** with multiple drivers of poverty and how gender inequality is exacerbated in fragile contexts;
 - define how IFAD's GEWE results from interventions at national and community level can be used for **advocacy, partnerships and knowledge management** to reinforce the Fund's visibility as key global player on GEWE in rural development.
194. **Recommendation 2.** Strengthen **the effectiveness of IFAD's interventions on GEWE** through consolidated guidance, promoting its **shared understanding and buy-in** among relevant stakeholders. To do so, develop:
- **pathways, tailored interventions and outcome-level indicators** for IFAD activities contributing to GEWE. Guidance could draw from the GEWE practices typology included in the Theory of Change for this evaluation. Prioritize developing the pathways towards GEWE outcomes through: **rural finance; land tenure security**, and activities contributing to a fairer distribution of **workload and shared benefits** between rural men and women;
 - a practical succinct guidance on **the application of Gender Transformative programming**, for all relevant decision makers, implementing partners and IFAD staff. It should include how Gender Transformative programming supports broader development goals, key definitions and examples of successful gender transformative project designs and pathways of change in different settings, the operational implications and additional requirements, with a description of roles and responsibilities, and capacities required. Ensure the note is available in all IFAD languages.

²³⁶ For instance, the survey conducted for the 2024 MOPAN assessment targeting external partners and country representatives of IFAD's Board.

- a stock-take of efforts to **measure (women’s) empowerment**, outlining the roles and responsibilities involved and any capacity gaps;
 - guidance for IFAD staff on how to do **policy engagement on GEWE** during the design and the implementation of COSOPs and Gender Transformative projects. It should emphasize communication and partnerships with relevant national (and international) partners.
195. **Recommendation 3.** Ensure the Fund has **human resources with the capacities and competencies** to address its GEWE priorities and leverage key partners as necessary. To do so:
- Update the 2019 **assessment of IFAD’s workforce technical expertise on gender and social inclusion** to identify any staffing gaps and clarify respective roles, priorities and responsibilities in the current decentralized structure. Ensure the available human and budgetary resources are **commensurate with the ambition** of IFAD GEWE goals and the gender-related replenishment commitments;
 - Strengthen the **support to project management units (PMUs) and other implementing partners** throughout the project cycle with the systematic inclusion of gender experts in IFAD field missions. Ensure community-generated data is consolidated and interpreted and the cost and benefits of specific approaches, such as Gender Action Learning System and *Cerrando Brecha* are included in IFAD’s reporting;
 - Partner with expert service providers to deliver **short trainings and peer-peer learning** (e.g., learning routes and web-based communities of practices) for IFAD staff and implementing partners. Capacity development efforts should take a practical perspective which emphasizes the **mindset shift for positive behaviour change about GEWE**, beyond the basic training on gender sensitization and key concepts;
 - provide targeted training on **policy engagement on GEWE** for country directors and other project staff in the country. This training should include discussions and analyses of successful examples that leveraged supplementary-funds and grants.
196. **Recommendation 4.** Establish **high-level metrics** to track and report progress towards IFAD’s GEWE goals to ensure **accountability** and promote **learning**. This should include:
- measures to assess the **quality of project designs to promote GEWE** and a robust monitoring and reporting system to **capture actual GEWE results** that IFAD interventions aim to catalyse at individual, household, community and policy/legislation levels;
 - concrete **actions to address gaps** identified from periodic assessments of **strategic issues** related to the implementation of all action areas of the new gender policy, the UNSWAP, the 5R Action Plan to improve Gender Parity and the Diversity, Equity and Inclusion Strategy;
 - lessons from regular stock takes drawing on GEWE M&E in operations focused on **successful project experiences and challenges**. Key human resources, such as PMU staff, should be part of these learning-oriented exercises.

Evaluation matrix

Figure 5

Report section	Overarching questions	Potential evaluation questions	Information sources/method proposed
<i>RELEVANCE: The extent to which IFAD support to GEWE is consistent with other IFAD strategies, beneficiary requirements, institutional priorities, (and the international agenda)</i>			
III. A.	OQ1	How relevant are the IFAD gender corporate documents to the 2030 Agenda and to the global and regional policy debates on food security, climate nutrition and youth?	Literature and desk review, review of RIDEs and ARRI, key informant interviews, interviews with gender experts and gender focal points
III.B	OQ1	How aligned and coherent are IFAD gender corporate documents with IFAD priorities and IFAD's overall strategic framework?	Benchmarking exercise, literature review, analysis of information in UNSWAP, interviews with IFAD management staff
III.D	OQ2	How consistent is IFAD's support to gender equality in the COSOPs and project-level gender strategies over the evaluation period, and is the overall quality consistent?	11 country case studies, interviews with IFAD operational staff and implementing partners, review of 25 COSOPs using template designed by Team, and review of key policies and procedures and guidelines for Country Strategies. Review of 23 IOE evaluations.
<i>COHERENCE: The extent to which the internal logic of the corporate gender framework is logical and promotes complementary to lending and non-lending activities of IFAD and is consistent with other actors' interventions in gender</i>			
IV.B and V.B	OQ2	How is the performance of IFAD non lending activities, such as Joint Programmes and grants? How do they reinforce IFAD's gender transformative agenda or enrich GEWE country programmes and project implementation?	Literature review, Desk review, Gender audit, Benchmarking analysis, Portfolio review, case studies, Survey
III.C	OQ1	How well does IFAD's GEWE approach compare with other international organizations?	Benchmarking exercise with 8 international organizations, interviews, literature review

Report section	Overarching questions	Potential evaluation questions	Information sources/method proposed
Knowledge management (domain to assess coherence): <i>The extent to which IFAD-funded initiatives are capturing, creating, distilling, sharing, and using knowledge on GEWE</i>			Literature review, 11 case studies, deep dives, Link with ongoing IOE CLE on KM. Website analysis
V	OQ2	How well is IFAD capturing, creating, and sharing knowledge on GEWE ²³⁷ ?	
Partnership building (domain to assess coherence): <i>The extent to which IFAD is building effective and sustainable partnerships with organizations (including those that represent rural women) so that they can implement GEWE and GTA approaches</i>			Literature review, benchmarking analysis, e-survey of staff, key informant interview, Review of targeting strategies, Grant analysis and analysis of three joint programme, Review of 25 COSOPs (to identify partnerships).
V	OQ2	How and to what extent is IFAD building timely, effective, and sustainable partnerships to realise its GEWE objectives (globally, regionally, and nationally)?	
Policy engagement (domain to assess coherence): <i>The extent to which IFAD and its partners are supporting gender equality policies or the extent to which IFAD is engaging with the integration of gender into other important policies, nationally or globally</i>			Key informant interviews, Literature and Desk review, field visits, observation, COSOP analysis.
V.C	OQ2	How is IFAD acting as a catalyst for advocacy and policy dialogue of GEWE at national and regional levels and at the international level?	
<i>EFFECTIVENESS: The extent to which GEWE results are achieved, including any differential results across groups as well as the extent to which GEWE interventions yield novel context specific approaches</i>			
II.B; IV	OQ1	How is GEWE measured at IFAD, from high-level to field operations? How GEWE measurement evolved during the evaluation period? What are the main features of the M&E and reporting systems to measure the contribution to GEWE of IFAD investment projects?	Review of 16 PDRs, WEAI analysis, Review of grants and joint programme, country case studies, QCA for 28 investment projects, deep dive on household methodologies.
IV.A	OQ2	How has GEWE performance ratings and trends evolved between 2013-2022?	Analysis of RIDEs and ARRI.
IV.B	OQ2	What are the most common GEWE practices (bundles of activities) in IFAD investment projects contributing to addressing the root causes of gender inequality and also contributing to the three gender strategic objectives?	Country case studies, QCA of all completed and evaluated projects since 2012, synthesis of 23 IOE evaluations.
Report section	Overarching questions	Potential evaluation questions	Information sources/method proposed

²³⁷ Are programmes and projects improving knowledge and evidence on GEWE (one of the results expected in the GAP (2019-2025) Mainstreaming GTAs at IFAD); to what extent is IFAD capturing, creating, distilling and sharing and using knowledge on GEWE?; How does IFAD capture information on the bundles of GEWE practices that may lead to GEWE transformative change?; How does information on GEWE feature in decisions on which innovations are ready for scale-up?; How does IFAD capture and share information on what 'more equal relations at household level' or 'communities and 'institutions being more supportive of GEWE' looks like in practice, and in different contexts?

<i>EFFECTIVENESS: The extent to which GEWE results are achieved, including any differential results across groups as well as the extent to which GEWE interventions yield novel context specific approaches</i>			
IV.C	OQ2	What are the key factors affecting GEWE performance of IFAD-supported interventions?	QCA, Portfolio, analysis, Analysis of gender grants and supplementary funds, Key informant interviews, Literature reviews, Desk review
II.D; VI.	OQ2	How is GEWE integrated with other mainstreaming themes (nutrition, climate change adaptation or youth-focused initiatives)? What challenges are there with regard to the integration of many such themes?	
IV.B.b	OQ2	What are the main Gender Transformative Approaches (or GEWE practices addressing the root causes of gender inequality) which have been implemented through IFAD projects and what are their results? And through non-lending instruments?	Key informant interviews, country case studies, portfolio review, e-survey, deep dive on household methodologies, analysis of grants and joint programmes
IV.D	OQ2	What is the overall quality of the gender transformative (GT) PDRs and their value added? What do the newer GT-validated projects propose to measure in terms of empowerment in the PDRs compared to what they actually measured in their baseline reports?	Review of 16 PDR with high gender ratings (8 validated as GT) and their baseline studies, interviews and country case studies with GT-validated projects.
VI.F	OQ3	How is IFAD performing internally, in terms of its gender and diversity balance and organizational culture?	Gender architecture and staffing review, e-survey, Interviews
INNOVATION *(subdomain of effectiveness): The extent to which GEWE interventions yielded a solution (practice, approach/method, process, product or rule) that is novel with respect to the specific context, timeframe and stakeholders.			e-Survey, Portfolio review, Key informant interviews, Case studies,
IV.B and V	OQ2	To what extent does IFAD work yield solutions that are novel with respect to GEWE?	
<i>EFFICIENCY: The extent to which GEWE strategies or interventions deliver or are likely to deliver results in an economic manner?</i>			
VI.E and VI.F	OQ3	How has IFAD's organizational structure been adapted to respond effectively to the 2012 gender policy? How do internal processes support GEWE operations?	e-Survey, Portfolio review, Key informant interviews, Literature reviews, Case studies, Gender audit Gender architecture and staffing review, key informant interviews, literature review, portfolio review, e-survey
VI.A, B, C, D	OQ3	How do resources (including human and financial resources, guidelines as well as institutional reporting processes) and IFAD GEWE capacities to address GEWE compare relatively with similar organizations?	
Report section	Overarching questions	Potential evaluation questions	Information sources/method proposed
<i>IMPACT: The extent to which GEWE interventions or IFAD's corporate practice has generated, or is expected to generate, significant positive or negative, intended, or unintended effects in terms of enabling rural women and men improve their food security, raise their incomes, or strengthen their resilience</i>			
IV.A and IV.B	OQ2	To what extent has IFAD investments in GEWE generated positive changes related to IFAD's strategic gender objectives: SO1: Access to resources and opportunities, SO2: enhanced voice, and SO3: reducing time poverty and better share of benefits.	Interviews with gender staff and other IFAD staff, literature review, QCA exercise, country case studies

IV.B.b	OQ2	What are the emerging results of transformative approaches as used by IFAD and partners to gender equality and are they contributing to GEWE performance for rural persons? What is the evidence beyond anecdotal success stories? (Is there a critical mass of evidence?)	QCA analysis, key informant interviews, country case studies, deep dive on HHM, grant analysis
<i>SUSTAINABILITY: The extent to which the net benefits of IFAD support to GEWE will continue or be scaled up by government authorities, donor organizations, the private sector, and other agencies.</i>			
V.C.	OQ2	How sustainable are the changes towards GE after the completion of IFAD interventions? What affects the sustainability of such changes?	Key informant interviews, IFAD Management self-assessment, Field visits, e-Survey, Country case studies, interviews, grant analysis.
Scaling up (domain of sustainability)			
V.C.	OQ2	What is the evidence that certain GTAs or GEWE interventions, investments, innovations, or approaches are likely to or are already being scaled up by government authorities, donor organizations, the private sector and other agencies? What examples exist where policy and legislative change on gender equality was, in some way, attributed to advocacy and policy dialogue linked to the results of IFAD interventions?	Interviews with government, and IFAD staff and country directors, RIA interviews, e-survey
Environment and natural resource management and climate change adaptation (domain of sustainability)			
III.D	OQ2	How well do the Social, Environmental and Climate Assessment procedures (SECAP) ensure that COSOPs and PDRs take into account gender issues? Are climate change vulnerability assessments gender-sensitive and propose actions to reinforce female farmers' resilience and encourage women's agency with respect to climate change actions?	Interviews with IFAD staff, deep dive on climate and gender, e-survey, synthesis of IOE 23 evaluations.

Additional definitions used in the evaluation.

Table 2
Gender related concepts and definitions in key IFAD documents

Concepts	Definitions in key documents from IFAD
Empowerment	<ul style="list-style-type: none"> - Refers to the process of increasing the opportunity of people to take control of their own lives. It is about people living according to their own values and being able to express preferences, make choices and influence – both individually and collectively – the decisions that affect their lives. Empowerment of women or men includes developing self-reliance, gaining skills or having their own skills and knowledge recognized, and increasing their power to make decisions and have their voices heard, and to negotiate and challenge societal norms and custom (2012 Gender policy, glossaries).
Gender	<ul style="list-style-type: none"> - Distinguishes the culturally based expectations of the roles and behaviours of women and men from the socially constructed from the biologically determined aspects of being female and male. Source: 2012 Gender policy, 2017 and 2021 gender glossaries, 2019 Gender Action Plan.
Gender equality	<ul style="list-style-type: none"> - women and men have equal rights, freedoms, conditions and opportunities to access and control socially valued goods and resources and enjoy the same status within a society; does not mean that the goal is that women and men become the same; - applies not only to equality of opportunity but also to equality of impact and benefits. Source: 2012 Gender policy, 2017 and 2021 gender glossaries. The definition in the 2019 GAP adds that equality, not only applies to equality of opportunity, but also to equality of access to the impact and benefits arising from economic, social, cultural and political development.
Gender Equity	<ul style="list-style-type: none"> - Means fairness of treatment for women and men according to their respective needs - Equity can be understood as the means, where equality is the end, equity leads to equality. Source: 2012 Gender policy, 2017 and 2021 gender glossaries, 2019 Gender Action Plan.
Gender Analysis	<ul style="list-style-type: none"> - Gender analysis helps to understand the different roles, interests and priorities of women and men, and tailor policies, projects and programmes accordingly. Source: 2012 Gender policy. The glossaries further developed: - Analysis of a social process or phenomenon from the point of view of the roles played by men and women. - Key issues include the division of labour (productive and reproductive activities), access to and control over resources and benefits, and social, economic and environmental factors that influence the above.
Gender Mainstreaming	<ul style="list-style-type: none"> - For IFAD as an institution, gender mainstreaming is the process by which reducing the gaps in development opportunities between women and men and working towards equality between them become an integral part of the organization's strategy, policies and operations. Thus, gender mainstreaming is fully reflected, along with other core priorities, in the mindset of IFAD's leadership and staff, and its values, resource allocations, operating norms and procedures, performance measurements, accountabilities, competencies and learning processes. In IFAD's development activities, gender mainstreaming implies assessing the implications for women and men of any planned action, including legislation, and ensuring that both women's and men's concerns and experiences are taken fully into account in the design, implementation and M&E of all development activities. The aim is to develop interventions that overcome barriers preventing men and women from having equal opportunity to access, and benefit from, the resources and services they need to improve their livelihoods. (2012 Gender policy and 2019 GAP, glossary).
Gender Parity	<ul style="list-style-type: none"> - The 2012 Gender policy and the 2019 GAP use the term "gender and diversity": an (organizational) approach that embraces diversity in gender, age, nationality, culture, beliefs, attitudes, language and social circumstances. - Gender parity refers to the equal representation of men and women within the 47 to 53 percent margin. The goal in the UN refers to gender parity in all staff categories and at all levels (UN System wide strategy on gender parity 2017; IFAD 5 R Gender Action Plan to improve gender parity).
Gender Transformative approaches	<ul style="list-style-type: none"> - Programmes and interventions that create opportunities to actively challenge the root causes of inequalities between women and men and promote positions of social and political influence for women (2019 GAP). - For a compendium of fifteen GTA good practices, see the 2020 publication by the JP-GTA Gender transformative approaches for food security, improved nutrition and sustainable agriculture. A compendium of fifteen good practices.
Gender Transformative Programming	<ul style="list-style-type: none"> - Gender transformative programming involves taking a gender transformative approach to project and programme design, implementation, monitoring and evaluation throughout the project cycle. Programming strategies move beyond women's empowerment towards transforming unequal power relations and the social institutions which perpetuate and reinforce gender inequalities. Source: Glossary of the Guidelines for measuring gender transformative change in the context of food security, nutrition and sustainable agriculture, developed by the JP-GTA.
Gender Transformative project	<ul style="list-style-type: none"> - IFAD Project design complying with certain criteria in relation to its specific situation analysis, theory of change, logframe indicators and dedicated human and financial resources (See Annex IX). Source: IFAD Operations Manual. Design. Annex VII. Mainstreaming Guidelines for social inclusion themes, 2023.
Household methodologies	<ul style="list-style-type: none"> - Methodologies that enable family members to work together to improve relationships and decision making and achieve more equitable workloads. Their purpose is to strengthen the overall well-being of households and all their members (2019 GAP, glossary).

Table 3
Comparison of the concept of gender mainstreaming in the IFAD policy and in the ECOSOC definition

<i>IFAD 2012 Gender Policy Annex 1</i>	<i>ECOSOC definition of gender mainstreaming strategy²³⁸</i>
<p>In IFAD's development activities gender mainstreaming implies assessing the implications for women and men of any planned action including legislation and ensuring that both women's and men's concerns and experiences are taken fully into account in the design implementation and M&E of all development activities. The aim is to develop interventions that overcome barriers preventing men and women from having equal opportunity to access and benefit from the resources and services they need to improve their livelihoods.</p>	<p>The process of assessing the implications for women and men of any planned action, including legislation, policies or programmes, in all areas and at all levels. It is a strategy for making women's as well as men's concerns and experiences an integral dimension of the design, implementation, monitoring and evaluation of policies and programmes in all political, economic and societal spheres so that women and men benefit equally, and inequality is not perpetuated. The ultimate goal is to achieve gender equality.</p>

²³⁸ Source: ECOSOC Agreed Conclusions. 1997. <https://www.un.org/womenwatch/osagi/pdf/ECOSOCAC1997.2.PDF>

Theory of change of IFAD interventions

Figure 6
Theory of change at the level of project investments (results chain from activities/GEWE practices to GEWE outcomes)

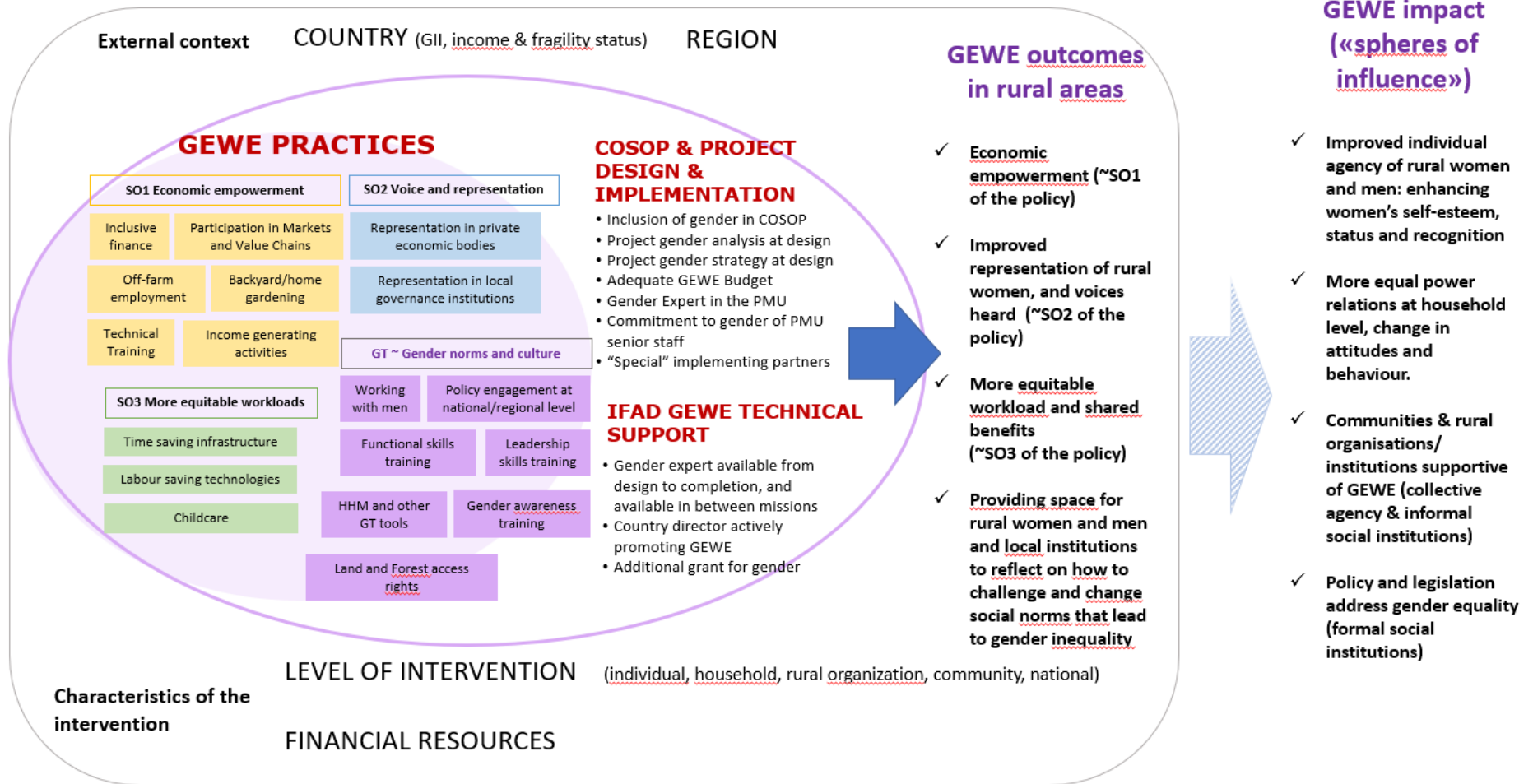

Figure 7

Assumptions

- Specific configurations of GEWE practices combined with other factors can effectively address and **overcome inhibiting contextual factors that are the root causes of gender inequalities**.
- Key **IFAD technical gender expertise** is sufficient, timely and capable of providing sound advice in different implementation contexts. Technical advice plays a crucial role in fostering the adoption of GEWE practices, extending lessons learned beyond the project's lifetime.
- IFAD senior management, staff and partners are **aware of key gender policies and strategies and are motivated** to implement GEWE approaches. This is reinforced through the right incentives such as staff performance assessment, corporate reporting and GEWE benchmarking, for example UNSWAP.
- Specific **project-level targeting** and gender strategies that consider various dimensions of inequality intersecting with gender, such as age, ethnicity are essential for achieving transformative gender outcomes.
- The involvement of a diverse range of **implementing actors, particularly those representing rural women** is crucial for identifying, adopting, and using GEWE practices that overcome potential inhibiting contextual factors.
- IFAD staff and implementing partners consistently remain aware of contextual factors related to gender, **adapting IFAD interventions as necessary. This includes making adjustments** based on gender monitoring during implementation, when needed.
- Positive **GEWE outcomes result from** the **interplay** between the specific **set of interventions (or GEWE practices)** implemented and **other elements** relating to both the national context and the form of the intervention (such as sector, level, and finance).
- The availability of adequate **resources** (financial, expertise, personnel) **dedicated to GEWE during project design and implementation significantly influences** the quality of GEWE practices.
- IFAD can efficiently mobilize country partners for implementing GEWE practices and **measuring gender outcomes and impacts**.
- There are **multiple pathways (or result chains)** to GEWE depending on the characteristics of the external context and the interventions. This includes diverse entry points for projects, such as a focus on nutrition, which can yield positive GEWE outcomes.
- **Transformative GEWE outcomes** necessitate interventions that extend significantly beyond improving access to resources at the individual level. These interventions should also target both men and women at the household and community level.
- Effective and impactful GEWE results are **shared and positively received by rural communities and institutional partners** leading to **scale-up** . National partners and other donors recognise IFAD as a pioneer in GTA.
- Transformative GEWE outcomes result in **long-term GEWE impacts** on women's agency, power relations within household, equity in sharing economic and social benefits, women's inclusion in decision-making and institutions, and the development of policy and legislations addressing gender equity.

Additional information on methodology used for TE on GEWE

Sources of evidence:

- 1. Analysis of GEWE outcomes reported**– See Annexes XV-XVII.
- 2. Synthesis of 23 IOE evaluation reports**

Objective: The objective of this Evaluation Synthesis was to capture evidence already available through IOE Evaluation Reports on GEWE and learn from such evidence. Additionally, the objective was to avoid replication. We were looking for patterns or trends of GEWE related issues emerging from evaluation reports, including identifying cases where GEWE approaches appeared to work effectively. We also expected to identify information gaps on the level of GEWE evidence that is available through evaluation reports to inform the choice of deep dives, or areas for data collection.

Sampling: evaluations conducted by the Independent Office of Evaluation of IFAD (IOE) for projects approved by the Executive Board after 2012, when the IFAD Gender Policy was approved.

Table 4
Analysis of key gender-related information in the most recent IOE evaluations

<i>Evaluation Framework Questions</i>		<i>With information</i>	<i>No/very limited information</i>
Relevance rating*			
A. Objectives and targets	At design, was gender mentioned in any of the expected outcomes, outputs, and targets?	23	0
	Any mention of female headed households? Were those modified during implementation?		
Inclusiveness of vulnerable/hard to reach categories	Was there any strategy in place for reaching the furthest behind? (e.g., indigenous/tribal women, widows/single/separated/divorced, landless women, female-headed households/others)?	22	1
B. Gender strategy	Is there any gender strategy?	20	3
	If yes, what does the evaluation report says about its quality and level of implementation/use?		
Budget allocation for gender	Was there a GEWE budget allocated?	17	6
C. Expressed priorities	To understand women priorities, did the design team use a participatory/consultation process/other? Same question during implementation?	15	8
	Did the interventions address women's expressed priorities?		
D. Alignment with IFAD GEWE policy objectives	How were the following included/addressed or extent to which efforts were made to address them:		
	SO1 women's economic empowerment	22	1
	SO2 decision making and representation	21	2
	SO3 equitable workload balance	16	7
E. Transformational approach intention in project designs	To what extent did the project challenges established gender beliefs and norms?	22	1
	Any evidence of overcoming the root causes of inequality and discrimination?	6	1
	Any evidence of promoting far reaching social change (for gender equality)?	4	3
	Any evidence of changes in social norms?	5	2
	Any evidence of changes in distribution of resource?	5	2
F. Inclusion of other cross-cutting issues in project designs	Did it bring about broader change beyond the immediate beneficiaries?	0	7
	To what extent the project addressed cross-cutting issues that have a significant impact on GEWE (climate change, conflict, migration, nutrition, others) or proposed to tackle through an integrated approach?	22	1
G. Alignment with national GEWE policies	To what extent did the project refer to national policies on gender equality or gender and agriculture strategies or national action plans on gender/women?	20	3

<i>Evaluation Framework Questions</i>		<i>With No/very limited information information</i>	
Effectiveness rating*			
A. Level of achievement of targets	Did the interventions achieve the intended results for the intended gender target?	23	0
	Did certain groups remain excluded?	23	0
	What were the main (intended and unintended) results achieved?	23	0
B. Achievement of IFAD GEWE's outcomes/results	To what extent the project contributed to meet the IFAD GEWE's objectives (outcomes level)? An any evidence about transformative change towards gender equality	21	2
C. Evidence and M&E	Is there mention of supporting evidence on GEWE's outcomes? (Quantitative, qualitative, impact studies, etc.)	22	1
E. Facilitating factors and hindering factors	What have been the key change factors or hindering factors on GEWE achievements?	20	3
F. Partnerships	Did the implementers had the technical capacity or commitment to deliver GEWE results?	10	13
	Did the project establish partnerships with local/national organizations, NGOS, and institutions working on GEWE?	19	4
G. Use of grants for GEWE work	Was there any use of grants to improve GEWE results? Any indication of funds used to address gender issues? (Effective use of budget allocation)	19	4
Rural poverty Impact rating*			
Rural poverty alleviation	How the gender interventions/practices impacted rural poverty (generally) and is this impact disaggregated?	17	6
	Any mention of how the project impacted differently men and women (older and younger) (household income and assets, human and social capital empowerment, food security and agricultural productivity, institutions and policies)? How did women and their families' lives change because of these interventions?	14	9
Sustainability rating*			
Sustainability	Which practices and results were sustainable? Any mentioned that link to GEWE? Are the financial support, activities, or institutions likely to continue the changes initiated by the project? Due to which factors?	15	8
Evaluation recommendations related to GEWE			
Recommendations	Was there any recommendation related to GEWE focus?	5	0
Lessons Learnt			
Lessons learnt	Any lessons learned on GEWE or on better poverty targeting? (Which would affect women specifically)	9	0

List of evaluation reports: 4CSPEs, 18PCR, 1PPE²³⁹

- 2017 **Bangladesh** Coastal Climate Resilient Infrastructure Project (CCRIP) PPE
- 2019 **Cambodia** Project for Agricultural Development and Economic Empowerment (PADEE) PCR
- 2019 **Nepal** CSPE
- 2019 **Seychelles** Competitive Local Innovations for Small-scale Agriculture Project (CLISSA) PCR
- 2019 **Vietnam** Sustainable Rural Development for the Poor Project in Ha Tinh and Quang Binh Provinces (SRDP) PCR
- 2020 **China** Yunnan Agricultural and Rural Improvement Project (YARIP) PCR
- 2020 **Mexico** Rural Productive Inclusion Project United Mexican States (PROINPRO) PCR
- 2021 **Mozambique** Pro-Poor Value Chain Development in the Maputo and Limpopo Corridors (PROSUL) PCR
- 2020 **Sao Tome and Principe** Smallholder Commercial Agriculture Project (PAPAC) PCR
- 2021 **Senegal** Agricultural Value Chains Support Project-Extension (PAFA-E) PCR
- 2020 **Uganda** CSPE
- 2021 **China** Jiangxi Mountainous Areas Agribusiness Promotion Project (JIMAAPP) PCR
- 2020 **China** Shiyuan Smallholder Agribusiness Development Project (SSADeP) PCR
- 2021 **Ethiopia** Pastoral Community Development Project III (PCDP II) PCR
- 2021 **Fiji** Agricultural Partnerships Project (FAPP) PCR
- 2021 **Guinea** National Programme to Support Agricultural Value Chain Actors-Lower Guinea and Faranah (PNAFA-LGF) PCR
- 2021 **Indonesia** CSPE Indonesia CSPE, 2019 **Madagascar** CSPE
- 2021 **Nepal** Improved Seed for Farmers Kisankalagi UnnatBiuBijan Karyakram (KUBK/ISFP) PCR
- 2021 **Rwanda** Climate-Resilient Post-Harvest and Agribusiness Support Project (PASP) PCR
- 2021 **Uruguay** Rural Inclusion Pilot Project (PIR) PCR
- 2021 **Vietnam** Commodity-oriented Poverty Reduction Programme Ha Giang Province (CPRP) PCR
- 2021 **Vietnam** Project for Adaption to Climate Change in the Mekong Delta in Ben Tre and Tra Vinh Provinces (AMD) PCR

3. Evolution of IFAD GEWE strategic approach: summarized in chapter II

4. Literature review – see list in annex XXIV

5. Organizational fit-for-purpose assessment:

The objective of the fit for purpose assessment was to assess the extent to which IFAD has mainstreamed gender throughout the Fund, as per the 2012 Policy on GEWE and the 2019 Gender action plan to mainstream gender transformative approaches.

²³⁹ CSPE: Country Strategy Programme Evaluation, Project Completion Report Validation, Project Performance Evaluation.

Research into how to conduct gender audits and “good practice” examples²⁴⁰ identified critical focus areas: (1) human and financial resources (2) accountability and reporting (3) internal processes (4) organizational culture. TE gender evaluation questions were aligned with these focus and sub-focus areas to ensure coverage of relevant issues identified in the approach paper approved by the Evaluation Committee.

The performance of IFAD in these critical focus areas was compared with other organizations with a UN/developmental mandate, including other Rome-based agencies: the UNDP, FAO, WFP and the World Bank. Information on these comparator organizations was obtained from secondary sources and key informant interviews with gender staff in these institutions.

6. Comparison of GEWE approaches with other organizations

This comparative analysis aimed to identify the similarities and differences of IFAD’s methods and performance relative to others, and to identify experiences of other organizations that may be relevant for IFAD.

Criteria applied for selecting the organizations for comparative analysis comprised: (1) organizations with a similar developmental/humanitarian mandate as IFAD, (2) similar target groups, (3) organizations with a gender strategy or a gender policy framework.

The comparators included: two international NGOs recognised as innovative in terms of gender work and poverty reduction (Care and OXFAM); two bilateral development and cooperation agencies working on GEWE/GTA in their own programmes (Swedish SIDA and Canadian GAC), two multilateral banks to compare the set-up, operations and performance (World Bank and the African Development Bank); and two UN agencies with comparable mandates or target groups with regards to GEWE/GTA (UNDP and FAO). WFP was later added for other analyses. WFP was not included in the main comparison exercise as their business model is very different to IFAD. For instance, the last gender evaluation at WFP did not use FAO or IFAD as a comparator, but UN agencies and NGOs working in emergency situations.

The comparative analysis involved document reviews and data analysis. As mentioned above, targeted interviews with key staff of some of these organizations were conducted to get additional data.

Some of the dimensions analysed were: (i) GEWE strategic objectives and reporting, (ii) GE (and WE) approaches, (iii) definitions and consideration of gender transformative (approaches) and (iv) innovation in gender work and results.

7. Eleven country case studies covering

Sampling: building on the proposal included in the Approach paper, and in consultation with the IFAD regional divisions and the gender team, box below describes the sampling criteria for the countries where the TE had a field mission.

Box 25

Sampling criteria to choose country case studies with field missions led by the TE team evaluation

- At least one country in each of the five IFAD regions (Asia and Pacific Region APR, West and Central Africa WCA, Eastern and Southern Africa ESA, Latin America and the Caribbean LAC, Near East, North Africa, Europe and Central Asia NEN);
- Countries with a new project design validated as gender transformative since 2019;
- Countries with an active portfolio (2-3 investment projects) approved after the gender policy (2012) with high and low GEWE performance (using ratings as the proxy);
- Other criteria: country fragility status, income level, presence of GEWE grants and programmes funded with supplementary funds.

²⁴⁰ (1) International Labour Office (ILO) 2012, *A manual for gender audit facilitators: the ILO Participatory Gender Audit methodology, second edition*; (2) European Institute for Gender Equality (EIGE) 2019, *Gender mainstreaming: gender audit*; (3) Canadian Audit and Accountability Foundation (CAAF) 2016, *Practice Guide to Auditing Gender Equality*; and (4) FAO gender audit, 2010 (recognised as good practice by the UNSWAP).

In addition, the TE team got coordinated with other IOE teams working in country programme evaluations (according to the IOE 's 2023 work programme). The final list of country case studies used in the TE are shown below.

Table 5
Countries selected for the TE case studies

<i>IFAD regions</i>	<i>TE field-based country visit</i>	<i>Coordination with other IOE evaluations</i>
APR	Cambodia	India
WCA	Cameroon	Mauritania
ESA	Kenya	Ethiopia
LAC	Argentina	El Salvador
NEN	Sudan and Tunisia*	Türkiye

*Sudan field mission had to be cancelled last minute due to civil political instability. It was covered through desk reviews and e-interviews, as it was done for Tunisia.

Guidance for all teams collecting data for TE case studies:

For *IFAD COSOPs and projects approved from 2013 onwards*:

1. What are the **main issues concerning gender equality in the country** over the evaluation period that relate to the IFAD country programme? (gender in country context)
2. What has been **IFAD's strategic approach to promote gender equality and women's empowerment at the country and project level**, over time? (consider coverage of IFAD gender policy objectives and efforts to mainstream gender throughout operations, address root causes of inequality, and engage in policy dialogue)
3. How does the **IFAD country programme/project(s) add value** to the promotion of GEWE in the country. Through what methods, approaches, partnerships?
4. What are the **outcomes and impact of IFAD's country programme/project(s)**? (See IFAD Evaluation manual).
5. What are the **results of any gender transformative approaches** that try to act on the root causes of gender inequality (social norms, gender roles and relations)? What worked well, what did not, and why?
6. Does the IFAD country programme / do individual projects have sufficient **human and financial resources to adequately cover gender and social inclusion matters** throughout the programme/project? Is **timely and good quality support** available from technical assistance or IFAD consultants or staff from the country office, multi-country office, regional office and/or HQ?
7. Has there been any **policy dialogue related to gender**? Please explain and identify any key partners. What are the results?
8. What are the **gaps/areas for improvement** in the IFAD country programme/project(s) to promote gender equality and women's empowerment?

Proposed output:

- A zero draft country note with bullet points.
- A written country note. Roughly 5 to 10 pages long.

Figure 8
Process to aggregate findings from the 11 case studies:

Evaluation questions	For Country case studies	Cambodia	Cameroon	Argentina	Kenya	Sudan	Tunisia	Ethiopia	For country notes	India	Turkey	Mauritania	El Salvador
Context (beyond IFAD control)													
EQ.3, EQ4	Main gender gaps in RD/agri sector Influence of country context								Q1. Issues concerning GE in the country				
IFAD's attempt at programme and portfolio level													
EQ5	Inclusion of gender in COSOP and PDR								Q2. IFAD's GEWE strategic approach				
EQ15, EQ16	Approaches used in IFAD projects for GEWE results								Q2 + Q3. IFAD GEWE added value + Q5. results of GTA/practices				
GEWE practices included in IFAD operations and their results													
EQ29, EQ30	GEWE practices								Q4. GEWE outcomes and impact + Q5				
EQ25, EQ27	How GEWE is measured across the portfolio												
Non-lending activities/efforts leading to Gender results beyond project/country level													
EQ10, EQ12, EQ14	Partnerships, KM, policy dialogue and influence								Partial Q7. GEWE policy dialogue				
Factors affecting GEWE performance													
EQ8	Understanding of gender concepts, including GT												
EQ23	IFAD technical support for GEWE outcomes % IFAD and government budget in projects Gender expert in PMU								Q6. Human and financial resources, GEWE support				
EQ10	Role of implementing partners								Q3. GEWE Partnerships				

COSOPs and investment projects covered in the eleven country case studies:

- Argentina:** COSOP (2016-2021) Inclusive Rural Development Programme (PRODERI 2011); Programme for Economic Insertion of Family Producers of Northern Argentina (PROCANOR 2015); Goat Value Chain Development Programme (PRODECCA 2016); Promotion of Resilient and Sustainable Agrifood Systems for Family Farming (PROSAF 2021);
- Cambodia:** COSOP (2013-2021) Project for Agricultural Development and Economic Empowerment (PADEE 2012); Agricultural Services Programme for Innovation, Resilience and Extension (ASPIRE 2014); Accelerating Inclusive Markets for Smallholders (AIMS 2016); Sustainable Assets for Agriculture Markets, Business and Trade Project (SAMBAAT 2019); Agriculture Services Programme for an Inclusive Rural Economy Agricultural Trade (ASPIRE-AT 2022) Sustainable renewable energy technologies (S-RET 2014);
- Cameroon:** COSOPs (2015-2019 and 2019-2024) Youth Agropastoral Entrepreneurship Promotion Programme (PEA Jeunes 2014) Commodity Value-Chain Development Support Project Phase II (PADFA II 2019); Aquaculture Entrepreneurship Development Support Programme (PDEA 2022);
- El Salvador:** COSOP (2015-2022) Rural Territorial Competitiveness Programme (Amanecer Rural effective in late 2011 (2010)); National Programme of Rural Economic Transformation for living Well (Rural Adelante 2015);
- Ethiopia:** COSOP (2016-2021) Pastoral Community Development Project III (PCDP III 2013); Participatory Small-scale Irrigation Development Programme II (PASIDP II2016); Lowlands Livelihood Resilience Project (LLRP 2019); Rural Financial Intermediation Programme III (RUFIP III 2020), Participatory Agriculture and Climate Transformation Programme (PACT In preparation); JP RWEEE Kenya 2014;
- India:** COSOPs (2011-2017 and 2018-2024) Integrated Livelihood Support Project (ILSP 2011); Jharkhand Tribal Empowerment and Livelihoods Project (JTELP 2012); Livelihoods and Access to Markets Project (LAMP 2014); Odisha Particularly Vulnerable Tribal Groups Empowerments and Livelihoods (OPELIP 2015); Andhra Pradesh Drought

Mitigation Project (APDMP 2016); Fostering Climate Resilient Upland Farming Systems in the North East (FOCUS 2017); Maharashtra Rural Women's Enterprise Development Project (Nav Tejaswini 2020); Chhattisgarh Inclusive Rural & Accelerated Agriculture Growth Project (CHIRAAAG 2021); Rural Enterprise Acceleration Project (REAP 2021);

7. **Kenya:** COSOPs (2023-2018 and 2021-2027) Cereal Enhancement Programme Climate Resilient Agricultural Livelihoods (KCEP-CRAL 2015); Aquaculture Business Development Programme (ABDP 2017); Kenya Livestock Commercialization Project (KeLCoP 2020);

8. **Mauritania:** COSOP/CSN (2012-2017 and 2018-2022) Poverty Reduction Project in Aftout South and Karakoro Phase II (PASK II 2011); Inclusive Value Chain Development Project (PRODEFI 2016); Sustainable Management of Natural Resources, Communal Equipment and the Organization of Rural Producers Project (PROGRES 2020);

9. **Sudan:** COSOPs (2013-2018 and 2020-2025) Livestock Marketing and Resilience Programme (LMRP 2014); Integrated Agriculture and Marketing Development Project (IAMDP 2017); Sustainable Natural Resources and Livelihoods Programme (SNRLP 2019);

10. **Tunisia:** COSOP/CSN (1998-2015, 2016-2018 and 2019-2024) Agropastoral Value Chains Project in the Governorate of Medenine (PRODEFIL 2014); Siliana Territorial Development Value Chain Promotion Project (PROFITS-Siliana 2016); Economic, Social and Solidarity Project (IESS-Kairouan 2019);

11. **Türkiye:** COSOPs (2010-2015 and 2016-2021) Goksu Taseli Watershed Development Project (GTWDP 2015); Murat River Watershed Rehabilitation Project (MRWDP 2012); Uplands Rural Development Programme (URDP 2017).

8. Analysis of 12 gender grants and 3 joint programmes:

Table 6
List of the twelve gender grants analysed in the TE.

	<i>Name</i>	<i>Dates</i>	<i>IFAD Financing</i>	<i>Country focus</i>	<i>Executing Agency</i>
1	Broadening Economic Opportunities for Rural Entrepreneurial Women	12/08/2012-30/06/2016	2.5 million	El Salvador, Guatemala, Nicaragua, Mexico	UN Women
2	Mobilizing public private partnerships in support of women-led small business development	30/11/2012-1/3/2017	1.3million	Afghanistan, Kyrgyzstan, Tajikistan	Aga Khan Foundation (AKF)
3	Grassroots Women's Groups Championing Transformative Rural Development Priorities in the Post-2015 Development Agenda - Forging Blueprints for Holistic, Bottom-Up Ownership & Implementation	25/11/2014-1/3/2016	0.25 million	South Africa, Zimbabwe, Zambia, Uganda, Kenya, Tanzania, Madagascar, Ghana, Cameroon, Nicaragua, Honduras, Guatemala, Jamaica, Brazil, Ecuador, Peru, Bolivia, India,	Huairou commission
4	Integrating Household Methodologies (HHM) in agricultural extension, value chains and rural finance in SSA	1/12/2014-30/6/2018	1 million – financial closure	Rwanda, Burundi, Democratic republic of Congo	Oxfam Novib
5	Strengthening gender M&E in rural employment in the NEN	8/12/2014-31/03/2018	1.72 million	Egypt, Jordan, Lebanon,	ILO

				Morocco and Tunisia	
6	Strengthening smallholder food security, income, and gender equity within West Africa's forest farm interface	12/12/2015-1/3/2019	1.5 million, financial closure	Burkina Faso; Ghana	CIFOR/CGIAR
7	Promoting the financial inclusion of young rural women	18/11/2016-0/06/2020	1.49million	Colombia, Mexico and Paraguay	Funda K (umbrella organization)
8	Scaling up empowerment through HHM (empower@scale)	7/12/2017-30/6/2022	2.25 million, Cofinancing	Nigeria, Kenya and Uganda	Oxfam Novib and Hivos
9	Assessing the Gendered Impact of Rural Development Projects	8/9/2018-31/12/2021	3.2 million Available for Disbursement	Mali, Nigeria, Ghana, Tanzania, Djibouti, Kenya	IFPRI (CGIAR)
10	Inclusive Red Meat Value Chains for Women and Young Farmers in East and Southern Africa	12/8/2020-31/12/2023	1 million	Malawi and Zimbabwe	ILRI (CGIAR)
11	Stepping up IFAD's Gender-transformative Agenda - Women's Land Rights Initiative	28/10/2020-31/3/2024	IFAD grant: 2 million, cofinancing	Bangladesh; Ethiopia; Uganda; Colombia; Kyrgyzstan; Niger and Gambia	CIFOR-ICRAF, IFPRI, CIAT
12	Melanesia Rural Markets & Innovation Development riven Programme (MERMAID)	23/11/2020-31/12/2023	2.8 million - available for disbursement	Solomon Islands, Vanuatu.	World Vision & CIAT

Figure 9
Geographic distribution of the gender grants

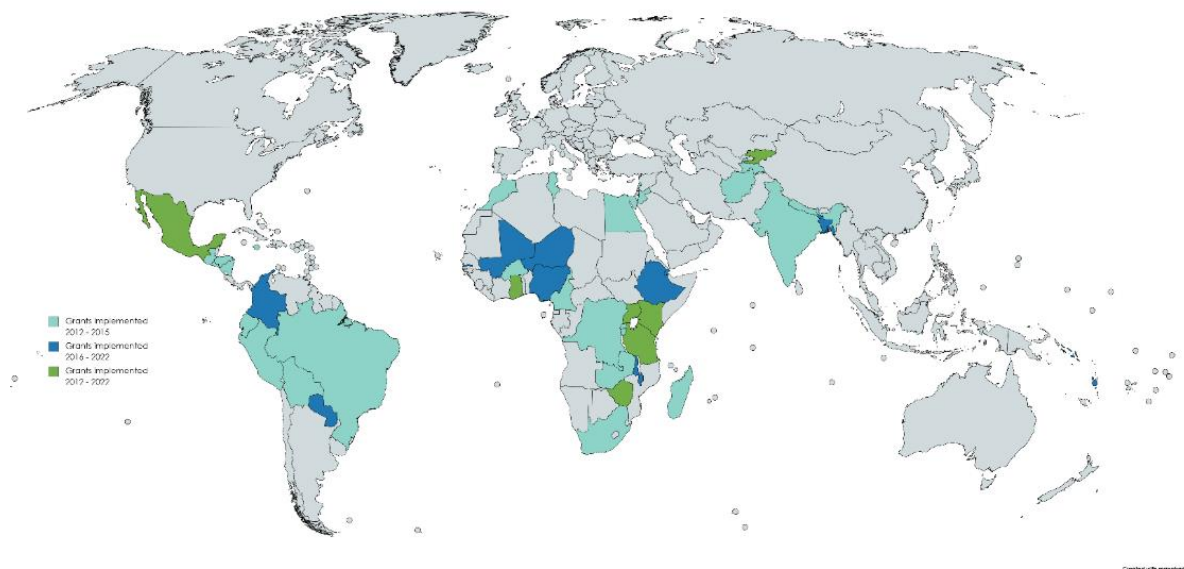

Figure 10
Regional distribution of the gender grants

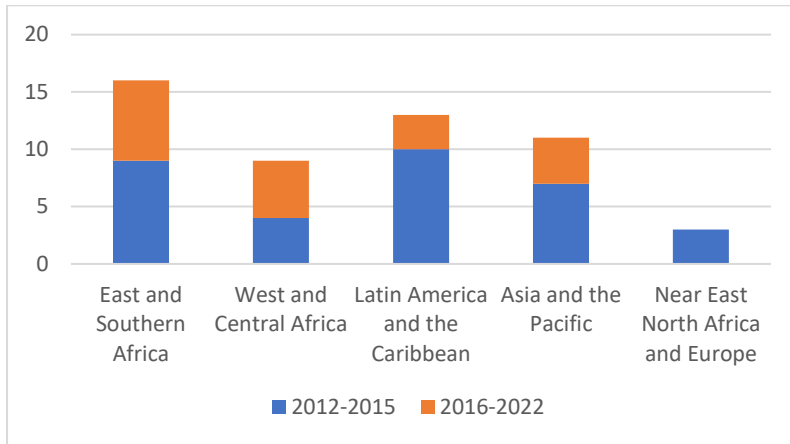

Figure 11
Distribution of the gender grants by type of recipient and period of approval

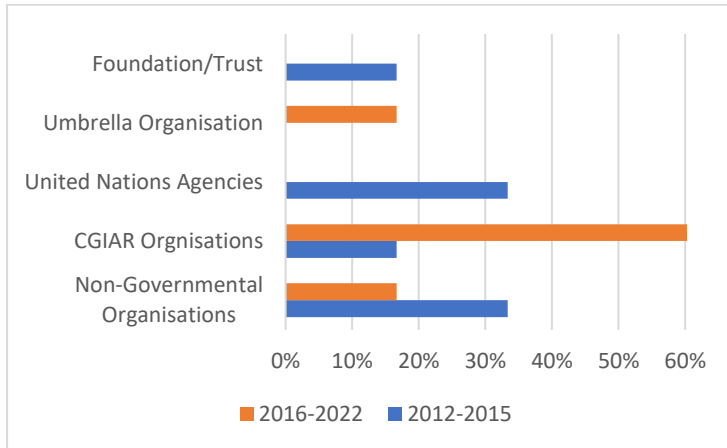

Figure 12
Amount and number of gender grants approved by year

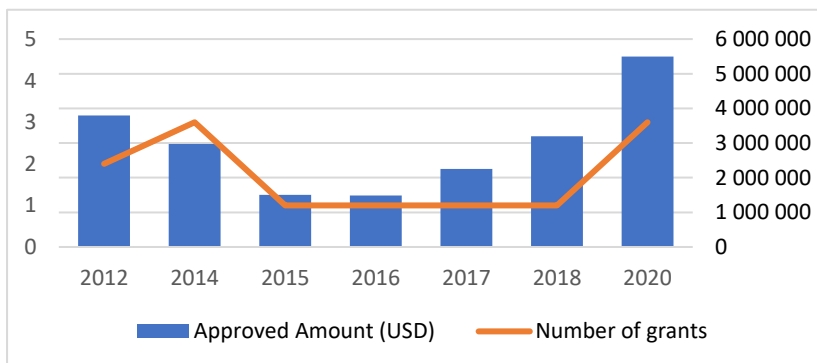

Table 7
Amount and number of supplementary-funded programmes during the evaluation period

	<i>Name</i>	<i>Dates</i>	<i>Financing</i>	<i>Country focus</i>	<i>Recipient</i>	<i>Implementing partner</i>	<i>Additional information</i>
1	Joint Programme on Accelerating Progress towards the Economic Empowerment of Rural Women (JP RWEE)	15/10/2012 - 30/06/2021	USD 35 million	Ethiopia, Guatemala, Kyrgyzstan, Liberia, Niger, Nepal and Rwanda	IFAD, FAO, WFP, UN- Women	Various	It reached approximately 80,000 women through a set of integrated efforts, focused on enhancing their access to opportunities, resources, and services. Each agency takes the lead in implementing country-level activities. This is accomplished through direct implementation and collaboration with local implementing partners.
2	EU-RBA Joint Programme on Gender Transformative Approaches for Food Security, Improved Nutrition and Sustainable Agriculture (JP GTA)	01/01/2019 - 31/12/2022	EUR 5 million	Ecuador and Malawi	Rome-based agencies	Ministries of Agriculture (and livestock) in both countries, Care, CGIAR, others	RBA are expected to embed gender transformative approaches in their policy dialogues, programmes, working modalities and institutional culture and enhance their collaboration on zero hunger and gender equality. The JP GTA is testing gender transformative programming and devising a minimum set of indicators and strengthening competency for GTA programming.
3	Gender Transformative Mechanism (GTM): Improving climate resilience and rural people's wellbeing by promoting gender transformative results	2021- 2026	US 16 million	Burkina Faso, India (and Ethiopia)	IFAD	Ministries of Agriculture in both countries, others	The B&MG Foundation programme aims to increase country-level capacity to produce gender-transformative results in the context of climate adaptation, using a strong focus on ownership through results-based approaches as well as contribute to the development of methodologies for measuring gender transformative change, climate adaptation and market inclusion.

9. Analysis of additional 25 COSOPs approved since 2016

Objective of the analysis of COSOPs: to provide an analysis of the extent to which IFAD has mainstreamed Gender in its Country Strategic Opportunity Programmes (COSOP). By definition, a country strategic opportunities programme (COSOP) is a framework for making strategic choices about IFAD operations in a country, identifying opportunities for IFAD financing and facilitating management for results.

Sampling method: From a sample of 70 COSOPs approved between 2016 and 2022, countries where IOE CSPEs were recently completed were prioritized, while ensuring at least one COSOP from each of the five IFAD regions. Three of the 25 countries selected for the analysis were considered fragile states: Ethiopia, Mozambique and Nigeria.

List of COSOPs reviewed: Bangladesh (2023-2028); Bolivia (2021-2025); China (2016-2020); Colombia (2016-2022); Côte d'Ivoire (2020-2025); Djibouti (2019-2024); Dominican Republic (2017-2020); Eswatini (2022-2027); Ethiopia (2016-2021); Georgia (2019-2024); Guinea (2020-2024); India (2018-2024); Kyrgyzstan (2018-2022); Lao (2018-2024); Mexico (2020-2025); Moldova (2019-2024); Mozambique (2018-2022); Nigeria (2016-2021); Peru (2019-2024); Rwanda (2019-2024); Senegal (2019-2024); Tajikistan (2019-2024); Togo (2022-2027); Uganda (2021-2027); Viet Nam (2019-2025).

Methodology used:

The analysis was based on a document review of 25 COSOP reports using the questions in the template developed by the TE GEWE Team in the table below. In order to understand the integration of GEWE in the COSOPs, the team wished to broadly understand whether the proposed gender approaches in the COSOP were suited to the priorities of different groups of rural women and the cultural contexts in the countries.

The team examined the extent to which national/institutional gender policies were mentioned, along with other key sector frameworks (e.g., agricultural investment plans). The TE GEWE also examined the overall quality of COSOP in terms of gender, and examined whether the COSOP indicated that field consultations and needs assessments informed the choice of the GEWE strategy for a project (ensuring priorities of target groups are considered) and how this relates to targeting strategies at design. The level at which IFAD predominantly focuses on GEWE in interventions was also examined (individual, household, community or regional/national).

Table 8
Results of the analysis of COSOP.

Dimension	Findings
Goal/Objectives (GEWE relevant highlighted by IOE)	All COSOP were found to have mainstreamed gender equality issues but to different extents. Seven (or 28%) of COSOPs in our sample of 25 COSOPs have defined specific GEWE objectives. Examples include Bangladesh, Guinea, Kyrgyzstan, Mexico, Mozambique, Togo and Uganda. In some cases, this translates into gender-sensitive strategic objectives that align with both national and IFAD priorities to eradicate poverty among rural populations.
Key instruments to tackle GEWE mentioned in the COSOP	<p>12 out of 25 COSOPs in the TE GEWE review or 48% from our sample set goals and objectives that were tailored and linked to national gender policies/strategies. Such countries include Colombia, Eswatini, Ivory Coast, Ethiopia, Guinea, Lao People's Democratic Republic, Mozambique, Nigeria, Peru, Senegal and Togo.</p> <p>In most of the countries, national policies, laws, and programs exist for the benefit of vulnerable groups, including women, youth, and in some cases indigenous peoples and people with disabilities. Very few COSOPs (8%) mentioned International Convention on the Elimination of All Forms of Discrimination against Women or CEDAW (Bangladesh and Rwanda alone). The Colombia COSOP reported a significant gap between legal frameworks and their implementation.</p> <p>In some countries, civil and customary law still treats women as minors, denying them access to productive resources - land, credit - (e.g., Eswatini). This is an area that requires further development and investment in many countries.</p> <p>In certain countries IFAD through COSOP agreement and negotiations with government, is making efforts to strengthen national policies and institutions in order to create an enabling environment for GEWE. For example, in Côte d'Ivoire and the Dominican Republic, COSOP strategic objectives support the implementation of land tenure laws, policies on access to financial services, and the participation of women in political dialogue and decision-making processes.</p> <p>It is reported in some COSOPs that the country either has no gender policy or is using an outdated gender policy. For example, Georgia does not yet have a specific gender strategy, and Tajikistan uses a gender policy dating from 2011 that may need updating. Peru is still in the process of implementing the National Plan for Gender Equality (PLANIG) 2012-2017. The National Gender Policy adopted in 1997 and revised in 2007 remains the main legal framework for gender equality and women's empowerment in Uganda. While some countries have sectorial gender strategies applied to agriculture, others do not.</p>
Consultation during COSOP formulation ²⁴¹	The primary target of IFAD's GEWE interventions in the COSOPs is the individual and the household. Most COSOPs are said to have involved the target beneficiaries during the preparation process to take their needs into account. But the level and approach of engagement varied from one COSOP to another. In some cases, the priorities of the target groups were considered during surveys/focus group discussions conducted in potential communities or by building on the experiences and lessons learned from past COSOPs. In other instances, stakeholder workshops/meetings were organized with the participation of producer organizations, civil society organizations that champion their members' causes, and those of vulnerable groups such as women, youth, people with disabilities, and indigenous people. Some countries, however, did not substantially involve the target groups in the preparation of the COSOP. The COVID 19 pandemic has contributed to some extent to this situation. Many COSOPs committed to later using participatory approaches to mobilize the rural population and ensure community ownership at the implementation stage of projects.
Targeting Strategies (GEWE relevant highlighted by IOE)	IFAD usually specifically mentions the importance of a focus on vulnerable groups including women, youth, indigenous people, people with disabilities, and migrants so that they can effectively benefit from IFAD interventions. Eighteen out of 25 (or 72%) COSOPs mentioned women as a vulnerable target group, demonstrating IFAD's long-standing targeting efforts. While the COSOPs generally refer to other vulnerable groups (young people, indigenous populations and people with disabilities), they do not mention the specific problems faced by these target groups by gender. The role of women as agents of change was not emphasized in any of the COSOPs, although some mention better integration of women and marginalized groups in decision-making at all levels would enhance GEWE outcomes.
COSOP inclusion of GEWE issues- quota system in use (IOE's assessment)	<p>8 out of 25 COSOPs (for example Eswatini, Guinea, Kyrgyzstan, Moldova, Rwanda, and Togo) advocate for the use of a gender quota system. For example, the COSOP for Eswatini has defined a quota for the participation of women (at least 40%), youth (40%), and persons with disabilities (8%) in COSOP project activities. For Guinea, a quota (at least 30%) should be applied to ensure the representation of women and youth in decision-making bodies.</p> <p>While the use of the quota system is an important step to ensure the specific inclusion of women in IFAD interventions, it requires an understanding of existing ratios of different groups prior to setting an increase in targeting. Other expected initiatives include targeted awareness raising, capacity building, and economic incentives to ensure meaningful participation of vulnerable groups.</p>
Mention of household methodologies	In some countries, COSOP implementation already involves the use of household methodologies across the project portfolio. Ten out of 25, or 40% of COSOPs referred to these methodologies, most often the Gender Action Learning System (GALS). For example, in Ethiopia, the COSOP has defined

²⁴¹ How does IFAD ensure that the proposed gender approaches in COSOP and interventions are suited to the priorities of different groups of rural women (including other dimensions of diversity which may be the basis of discrimination against women, such as disability, age, ethnicity/race, and marital status, among others) and the cultural contexts in countries?.

	specific GEWE actions to promote household methodologies and labour-saving technologies to reduce women's workload. In summary, the COSOPs show a growth in popularity of household methodologies approaches.
COSOP with gender indicators	All COSOPs have a clearly defined results management framework with specific results indicators, and the majority have a gender-sensitive indicator to measure gender results. 18 out of 25 COSOPs have gender-specific indicators, such as Bangladesh, Côte d'Ivoire, Djibouti, Dominican Republic, Eswatini, Georgia, Guinea, India, and Kyrgyzstan. Moreover, we found considerable gaps in the collection of gender-disaggregated data across all the COSOPs. For instance, no COSOP proposed disaggregating data on young people by gender, and no COSOP referred to specific problems faced by other target groups by gender. There is still a need to emphasise how gender intersects with other social groups in M&E.
COSOP recommendations concerning gender	COSOPs generally contain recommendations, which in general, refer to the need to invest in specific agricultural sectors, or to the need for institutional reform (e.g., access to loans for farmers). Out of 25 COSOPs, 8 mentioned gender-related issues in their recommendations. These are: Bangladesh, Bolivia, Eswatini, Georgia, Lao People's Democratic Republic, Nigeria, Rwanda, and Uganda.
The overall quality and project-level gender strategy	The COSOPs have all made efforts to integrate gender issues, but to varying degrees. COSOPs would be expected to integrate GEWE issues throughout. Bangladesh's COSOP indicates a GEWE strategy based on gender mainstreaming, and the COSOP is committed to designing all projects in consultation with beneficiaries, including women. Similarly, in China's COSOP, three of IFAD's four commitments (namely gender transformative, youth mainstreaming and climate financing) are mentioned as having been integrated into projects in the COSOP framework.

As part of the document review, we also reported on countries progress in relation to gender based on two global gender indicators which are the Gender Inequality Index (GII) and the Gender Development Index (GDI) using the year 2017 and 2021. Scores for both are outlined in the Table below.

Table 9
Gender Development Index and Gender Inequality Index in selected Countries in 2017 and 2021.

Country	Gender Development Index		Gender Inequality Index	
	2017 ²⁴²	2021 ²⁴³	2017	2021
Bangladesh	0,881	0,898	0,542	0,93
China	0,955	0,984	0,152	0,192
India	0,841	0,849	0,524	0,49
Lao People's Democratic Republic	0,934	0,949	0,461	0,478
Viet Nam	1,005	1,002	0,304	0,296
Ethiopia	0,846	0,921	0,502	0,52
Rwanda	0,941	0,954	0,381	0,388
Eswatini	0,943	0,986	0,569	0,54
Mozambique	0,904	0,922	0,552	0,537
Uganda	0,685	0,927	0,523	0,53
Mexico	0,954	0,989	0,343	0,309
Peru	0,95	0,95	0,368	0,38
Bolivia	0,929	0,964	0,45	0,418
Dominican Republic	0,989	1,014	0,451	0,429
Colombia	0,997	0,984	0,383	0,424
Djibouti	0	0	0	0
Georgia	0,975	1,007	0,35	0,28
Kyrgyzstan	0,96	0,966	0,392	0,37
Republic of Moldova	1,005	1,01	0,226	0,205
Tajikistan	0,933	0,909	0,317	0,285
Côte d'Ivoire	0,841	0,887	0,663	0,613
Guinea	0,81	0,85	0	0,621
Nigeria	0,868	0,863	0	0,68
Senegal	0,911	0,874	0,515	0,53
Togo	0,822	0,849	0,567	0,53

²⁴² <https://hdr.undp.org/system/files/documents/2018humandevlopmentstatisticalupdatepdf.pdf>

²⁴³ https://hdr.undp.org/system/files/documents/global-report-document/hdr2021-22pdf_1.pdf

10. Analysis of all completed projects – 29 projects analysed using Qualitative Comparative analysis

Objective: The objective of using the QCA was to understand better what can be considered as “success factors” or “hindering factors” for achieving high gender performance in IFAD projects²⁴⁴. The QCA conditions are directly related to those in the ToC of the TE. They encompass IFAD project activities which contribute to GEWE results (GEWE practices) along with contextual factors, either related to the projects themselves or to the country implementation context. The main objective of using QCA was to test if this software managed to identify combinations of dimensions influencing gender performance of rural development projects, beyond the usual reporting of individual projects.

Theory-based framework for the QCA: A framework was developed to guide the QCA conditions that were used throughout this analysis (see Figure below). The framework was developed based on a literature review and findings from an earlier evaluation synthesis undertaken by IOE, and the TE Theory of Change.²⁴⁵ The IFAD Gender team from the Environment, Climate, Gender and Social Inclusion Division was consulted, and their inputs were considered in the finalization of this framework. Figure below outlines the numbering of the conditions included in the analysis that guided the data extraction process from the Project Completion Reports of the 28 cases.

Data collection and analysis phases. The following steps were taken for the QCA analysis. Firstly, a desk review of the project completion reports (PCRs) was conducted. Secondly, inputs were collected from project teams via email to fill information gaps. Thirdly, an additional desk review of project design and supervision reports was conducted (for some indicators). Secondary data from IFAD internal monitoring systems and sources such as other work from IOE also enriched the dataset.

Indicators for the QCA: The indicators (also called conditions, dimensions or factors in the analysis) were grouped into three domains: 1) GEWE practices²⁴⁶; 2) Contextual factors (project and country-level context); and 3) Project design and implementation characteristics.

²⁴⁴ The first QCA-related analysis compared the **prevalence of certain factors/dimensions/conditions of the framework** in the two groups of projects (those projects with high and with low rating). The second identified, if a **single condition appears to be necessary or sufficient** to achieve a high (or low) gender rating, and then if any combination of pair of conditions consistently leads to higher or lower project gender ratings (Super Subset Analysis). Next, an analysis of **combinations of four or five conditions** was undertaken, first to choose which contextual conditions led to less contradictory results among the groups, and then to identify models where the GEWE practices are combined with key contextual factors to explain higher or lower gender ratings. This encompassed the comparison of combinations with the same gender rating to merge those with only one difference and simplify the model without losing causal power (Boolean minimisation). It also entailed the comparison of combinations with different gender rating to identify the condition explaining this difference (INUS analysis).

²⁴⁵ The [2017 IOE synthesis](#) was used as the basis. Another synthesis of IOE evaluations was conducted in 2022 in the framework of this TE, covering 23 evaluations of projects approved after 2012.

²⁴⁶ Building on the IFAD GEWE practices identified in the [IOE 2017 evaluation synthesis](#), the TE team proposed 18 GEWE practices, which are clustered by the three IFAD gender policy strategic objectives, plus an additional category of practices or groups of activities potentially contributing to gender transformative changes.

Figure 13
QCA framework

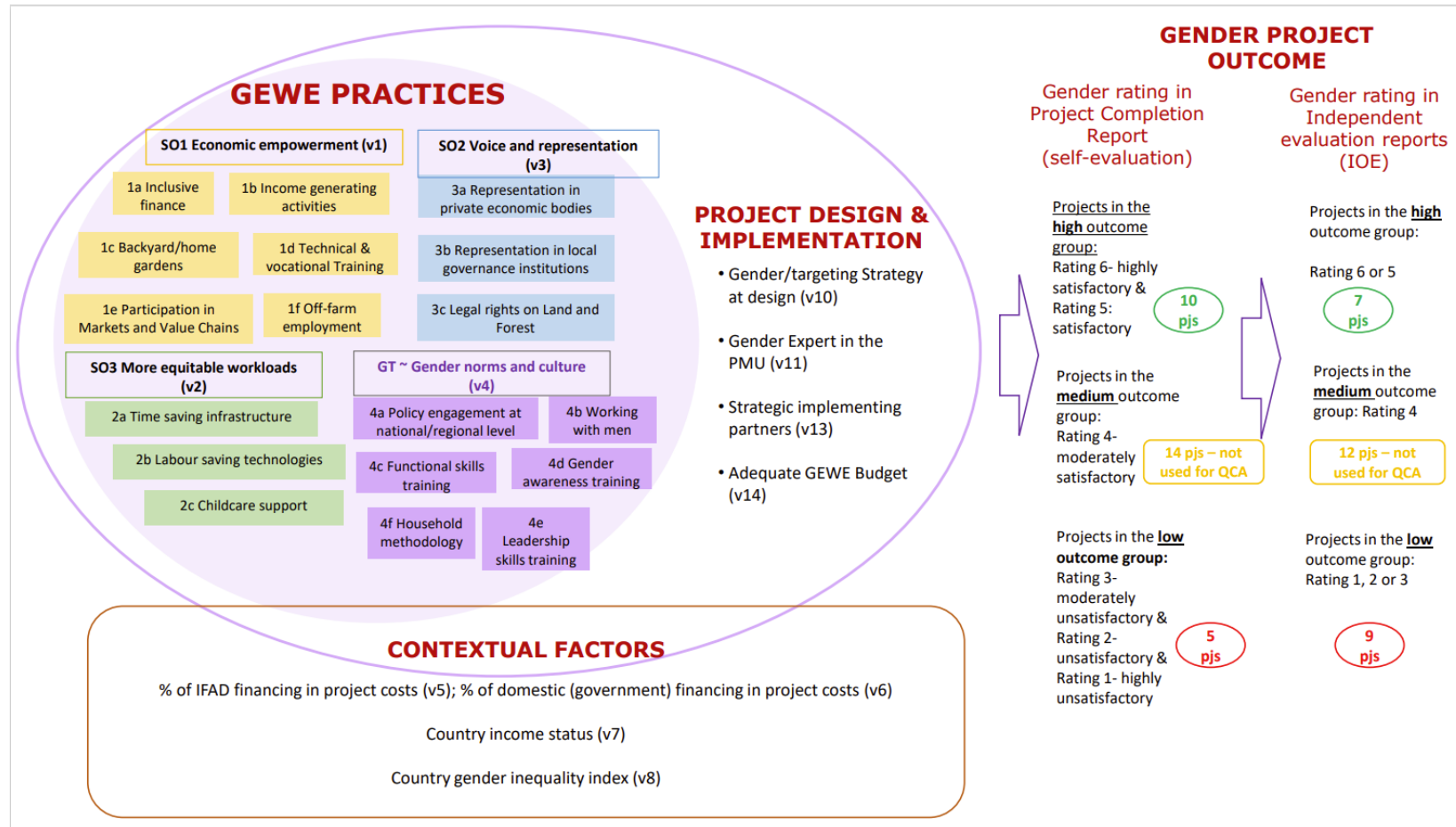

Completed investment projects analysed: All completed projects with a Project Completion Report available and a IOE GEWE ratings (28 cases). All completed projects approved after the gender policy (2013 onwards) and evaluated by IOE were included in the analysis which resulted in 28 cases for analysis. The Solomon Islands project-evaluation was discarded because it did not have a gender rating by the time of the analysis.

Because of the nature of the methodology, it is difficult to use and properly compare “middle cases” (those getting a rating of 4). For this reason, the **main data set** was composed of 16 cases (9 with low GEWE rating and 7 with ratings 4+). The robustness of the findings was also tested in an **expanded data set** with 3 additional cases with high GEWE rating by management (but 4 by IOE), total of 19 completed projects.

Table 10
Distribution of completed projects according to their gender rating reviewed using QCA

	<i>LOW OUTCOME</i> <i>Projects with low gender rating</i>	<i>HIGH OUTCOME</i> <i>Projects with high gender rating</i>	<i>Total projects</i> <i>used in QCA</i>
		7 cases	
Main data set	9 cases	Ethiopia Pastoral community III	16 cases
		Guinea PNAFA – LGF Expansion	
		Nicaragua NICADAPTA	
	Côte d'Ivoire PROPACOM/WNW	Uruguay PPIR	
	Cuba PRODECOR	Viet Nam SRDP	
	Fiji FAPP	Viet Nam CPRP	
	Georgia AMMAR	Viet Nam AMD	
	India APDMP		
	Lao FNML		
Expanded data set	Rwanda PASP	10 cases	19 cases
	Seychelles CLISSA	Same as above +	
	Togo PNPFR		
		Bangladesh CCRIP*	
		China MAPRP*	
	Kyrgyzstan LMDP II*		

*Additional projects rated 5 by PCR (self-assessment) and 4 by IOE

Additional completed projects analysed through descriptive statistics (because their IOE and PCR gender rating was 4 and QCA could not analyse them):

China Shiyan Smallholder Agribusiness Development Project (SSADeP, 2013),

China Jiangxi Mountainous Areas Agribusiness Promotion Project (JiMAAPP, 2014),

Djibouti Programme to Reduce Vulnerability in Coastal Fishing Areas (PRAREV-peche, 2013), **Mexico** Rural Productive Inclusion Project (2015),

Nigeria Climate Change Adaptation and Agribusiness Support Prog in the Savannah (CASP, 2013),

Moldova Inclusive Rural Economic and Climate Resilience Programme (IRECR, 2013),

Sao Tome and Principe Smallholder commercial agriculture project (PAPAC, 2014),

Senegal Agricultural Value chain support project extension (PAFA-E, 2013),

Solomon Islands Rural Development programme phase II (RDP II, 2015).

11. Analysis of 74 investment projects which included household methodologies:

Methodology: It is mainly based on IFAD the review of documents about the theory and practice of the implementation of these approaches and methodologies. Some interviews were held with the IFAD gender team in charge of HHM to complete the analysis.

The extraction of key HHM information of each project's documentation was coded across specific dimensions encompassing implementation specifics, success factors, constraints, outcomes, lessons learned, and HHM-specific good practices. The data coded for each project, summarized and tabulated in tables (see an example below), formed the basis for a subsequent comparative analysis. This analysis did not perform a comparison of IFAD projects with or without HHM (or GALS), but captured a diverse practice and results when HHM were embedded in IFAD projects.

Table 11
Example of data extracted for projects active on HHM

Code	Region	Country	Project ID	Project name	Duration	Last SVP GEWE Rating	Use of HHM from self-reports	Key issues from self-reports	Results from self-reports
1	APR	Kiribati	1100001708	OIFWP	2014 – 2023	-	-	-	-
2	APR	Nepal	1100001724	(RERP	2015 – 2022	-	-	-	-

Sampling: The universe of IFAD projects which included HHM was received from the IFAD gender team in February 2023. Sampling criteria were applied, see table below.

Table 12
Projects reviewed by the TE.

	Projects received from HQ IFAD gender team	Projects reviewed for the TE and sampling criteria
Projects where HHM is actively implemented ("active projects")	29	All, 29
Projects where HHM is not being implemented despite of project being approved more than two years ago ("not yet moving") ²⁴⁷	39 ²⁴⁸	19: All completed projects (9) + all from APR, LAC, NEN regions (with less "active projects", 10)
Projects including HHM and recently approved/entry into force ("recent design")	26	26
Total	94	74

List of investment projects including household methodologies:

East and Southern Africa (ESA):

Projects with active HHM: Malawi Sustainable Agricultural Production Programme (SAPP 2011); Kenya Upper Tana Catchment Natural Resources Management Project (UTaNRMP 2012); Madagascar Vocational Training and Agricultural Productivity Improvement Programme FORMAPROD 2012); Uganda Project for Financial Inclusion in Rural Areas (PROFIRA 2013); Zambia Rural Finance Expansion Programme (RUFEP

²⁴⁷ HHM were included in PDR but not yet implemented according to last supervision reports or HHM was incorporated following recommendations from the mid-term review.

²⁴⁸ The original list included 36. Three additional projects were added by the TE team: two in Malawi were mentioned in one the reviewed one and an additional one from Ethiopia was added after the country case study.

2013); Burundi National Programme for Food Security and Rural Development in Imbo and Moso (PNSADR-IM 2014); Uganda Project for the Restoration of Livelihoods in Northern Uganda (PRELNOR 2014); Sudan Livestock Marketing and Resilience Programme (LMRP 2014); Burundi Value Chain Development Programme Phase II (PRODEFI II 2015); Kenya Cereal Enhancement Programme Climate Resilient Agricultural Livelihoods Window (KCEP-CRAL 2015); Malawi Programme for Rural Irrigation Development (PRIDE - ERASP blended 2015); Rwanda dairy development project (RDDP 2016); Kenya Aquaculture business development programme (ABDP 2017); Madagascar Inclusive Agricultural Value Chains Development Programme (DEFIS 2017); Malawi Financial Access for Rural Markets, Smallholders and Enterprise Programme (FARMSE 2017); Sudan Integrated Agriculture and Marketing Development Project (IAMDP 2017); Uganda National Oil Palm Project (NOPP 2018);

Projects with HHM but not yet moving: Eritrea National Agriculture Project (NAP 2012); Zambia Enhanced Smallholder Livestock Investment Programme (E-SLIP 2014); Eritrea Fisheries Resource Management Programme (FReMP) 2016; Comoros Family Farming Productivity and Resilience Support Project (PREFER 2017); Burundi Financial Inclusion in Burundi (PAIFAR 2017); Angola Smallholder Agriculture Development and Commercialization Project in Cuanza Sul and Huila Provinces (SADCP-C&H-SAMAP 2017)

Projects with HHM recently approved: Uganda National Oilseeds Project (NOSP) 2019; Sudan Sustainable Natural Resources and Livelihoods Programme 2019; Eritrea Integrated Agriculture Development (IADP 2020); Kenya Livestock Commercialization (KeLCoP 2020); Kenya Rural Kenya Financial Inclusion Facility (RK-FINFA 2021); Lesotho Restoration of Landscapes and Livelihoods (ROLL 2021); Rwanda Kayonza Irrigation and Integrated Watershed Management Phase II (KIIWP2 2021); Djibouti Integrated Water Resources Management Project 2021; Madagascar Programme to Strengthen Sustainable Entrepreneurship and Support Economic Integration of Rural Youth (PROGRES 2022); Rwanda Promoting Smallholder Agro-Export Competitiveness Project (PSAC 2022); Zimbabwe Horticulture Enterprise Enhancement Project (HEEP 2022); Ethiopia Participatory Agriculture and Climate Transformation Programme (PACT 2022);

Projects with HHM but not analysed: Ethiopia Participatory Small-scale Irrigation Development Programme II (PASIDP II 2016); Zambia Enhanced Smallholder Agribusiness Promotion Programme (E-SAPP 2016); Burundi Agricultural Production Intensification and Vulnerability Reduction Project (PIPARV-B 2018); Angola Smallholder Resilience Enhancement Project (SREP 2019); Ethiopia Lowland Livelihood Resilience Project (LLRP 2020).

West and Central Africa Division (WCA):

Projects with active HHM: Nigeria Value Chain Development Programme (VCDP 2012); Chad Project to Improve the Resilience of Agricultural Systems in Chad (PARSAT 2014); Ghana Agricultural Sector Investment Programme (GASIP 2014); Burkina Faso Agricultural Value Chains Promotion Project (PAPFA 2017); Chad Strengthening Productivity and Resilience of Agropastoral Family Farms (RePER 2018); Mali Inclusive Finance in Agricultural Value Chain Project (INCLUSIF 2018); Sierra Leone Agricultural Value Chain Development Project (AVDP 2018); Gambia Resilience of Organizations for Transformative Smallholder Agriculture Programme (ROOTS 2019);

Projects with HHM but not yet moving: Ghana Rural Enterprises Programme (REP 2011); Mali Rural Youth Vocational Training, Employment and Entrepreneurship Support (FIER 2013); Sierra Leone Rural Finance and Community Improvement Programme II (RFCIP II 2013); Nigeria Climate Change Adaptation and Agribusiness (CASP 2013); Guinea-Bissau Economic Development Project for the Southern Regions (PADES 2015); Côte d'Ivoire Agricultural Value Chain Development Support Programme (2017); Benin Agricultural Development and Market Access Support Project (PADAAM 2018);

Projects with HHM recently approved: Democratic Republic of the Congo Inclusive and Resilient Rural Development Support Project (PADRIR 2019); Central African Republic Project to Improve the Productivity and Access to Markets of Agricultural products in the Savannah zones (PRAPAM 2020); Chad Strengthen Innovation in Youth and Women Agro-pastoral Entrepreneurship in Chad (RENFORT 2021); Cameroon Aquaculture Entrepreneurship Development Support Programme in Cameroun (PDEA 2022);

Projects with HHM not analysed: Liberia Tree crop extension project (TCEP 2015); Benin Market Gardening Development Support Project (PADMAR 2016); Nigeria Livelihood Improvement Family Enterprises Project in the Niger Delta (LIFE-ND 2017); Central African Republic Project to Revitalize Crop and Livestock Production in the Savannah (PREPAS 2018); Guinea Family Farming, Resilience and Markets project in Upper and Middle Guinea (AgriFARM-HMG 2018); Liberia Tree crop extension project II (TCEP II 2018); Senegal Rural Youth Agripreneur Support Project (AGRI-JEUNES 2019); Benin Agricultural Development and Market Access Support Project (PADAAM 2019).

Asia and Pacific region (APR):

Projects with active HHM: Kiribati Outer Islands Food and Water Project (OIFWP 2014); Nepal Samriddhi Rural Enterprises and Remittances Project (RERP 2015); Nepal Agriculture Sector Development Programme (ASDP 2017);

Projects with HHM but not yet moving: Papua New Guinea Market for Village Farmers (MVP 2017);

Projects with HHM recently approved: Nepal Value chains for Inclusive Transformation of Agriculture Programme (VITA 2020); Cambodia Agriculture Services Programme for an Inclusive Rural Economy and Agricultural Trade (ASPIRE-AT 2022); Bhutan Building Resilient Commercial Smallholder Agriculture (BRECSA GAFSP 2022); Lao People's Democratic Republic Agriculture For Nutrition Phase 2 (AFN II 2022);

Projects with HHM but not analysed: Bangladesh Promoting Resilience of Vulnerable through Access to Infrastructure, Improved Skills and Information (PROVATI) 2017); Indonesia Development of Integrated Farming Systems in Upland Areas (UPLANDs Project 2019); Indonesia Integrated Village Economic Transformation Project (Trasformasi Ekonomi Kampung Terpadu TEKAD 2019).

Near East, North Africa and Europe Division (NEN):

Projects with active HHM: Kyrgyzstan Access to Markets Project (ATMP 2016);

Projects with HHM but not yet moving: Bosnia and Herzegovina Rural Competitiveness Development Programme Not available yet; Uzbekistan Dairy Value Chains Development Programme (DVCDP 2015); Tunisia *Projet de promotion des filières pour le développement territorial* de Siliana (PROFITS 2016); Tajikistan Community-Based Agricultural Support Project (CASP 2017);

Projects with HHM recently approved: Bosnia and Herzegovina Rural Enterprises and Agricultural Development Project (2018); Tunisia Economic, Social and Solidarity Project (IESS-Kairouan 2019); Kyrgyzstan Regional Resilient Pastoral Communities (RRPCP 2021); Syrian Arab Republic Revitalisation of Agricultural Livelihoods Programme;

Projects with HHM but not analysed: Egypt Promoting Resilience in Desert Environments (PRIDE 2017).

Latin America and Caribbean Division (LAC):

Projects with HHM but not yet moving: Cuba Proyecto de Desarrollo de Cooperativas Ganaderas en la Región Central Oriental (PRODEGAN 2016);

Projects with HHM recently approved: Ecuador Sustainable and Appropriate Development Project in Rural Territories (DESATAR 2020); Dominican Republic Productive Inclusion and Resilience of Poor Rural Youth Project (PRORURAL Joven 2021);

Projects with HHM but not analysed; El Salvador National Programme of Rural Economic Transformation for Living Well (Rural Adelante 2015).

12. Analysis of 16 Project Design Reports with high gender rating, of which 8 validated as gender transformative (to be completed)

Objective: The purpose of this exercise was to assess the distinctive features of project designs validated as gender transformative, in relation to other designs not validated as gender transformative.

Analytical framework: The review framework was inspired by the descriptors of the IFAD gender marker, which were fine-tuned at IFAD with the 2019-2025 GAP and included in the annex of IFAD's operational manual. The framework was also inspired by the work in 2022 of an external consultant, previous IFAD gender lead, who analysed the designs of 28 projects validated as gender transformative. It was finalized with the consultation of IFAD gender experts. See table below.

Methodology: The main documents reviewed and assessed for the deep dive were project design reports (PDR) and their annexes. Each PDR was reviewed against the criteria below and points awarded as follows: 0 = no reference, 0.5 = partially fulfilled, 1 = completely met.

Therefore, the maximum score for a GM PDR is 10 points and for a GT PDR is 22 points (according to the number of criteria for each). It was assumed that all GT projects would fulfil the criteria for GM (column on the left) – when the reviewer considered this was not the case, it was flagged separately.

Sampling: The evaluation team expected that all GT-validated projects were going to be part of the QAG list of designs rated 6 for gender. Only the three sampled projects are in this category. Five additional GT-validated projects since 2019 were selected from a list of 23 projects rated 5 for gender by QAG (one per region, considering fragility status and potential country case studies). Additionally, the four projects not validated as GT but which received a rating of 6 by QAG were sampled, and additional four projects were purposefully selected with rating 5 and not validated as GT, see list below.

Table 13
Review framework for Project Design Reports

Dimension	For Gender mainstreaming (GEWE rating 5) and GT (GEWE rating 6)	Additional features for Gender transformative (GEWE rating 6 or GT projects)	Criteria
Situational (gender) analysis	<p>Does the situational analysis mention, use or describe national policies, key statistics/data, strategies and actors addressing gender in the agriculture/rural development sector in the country?</p> <p>As part of the situational analysis, was there a gender analysis to document the root causes of inequalities, and discriminatory social, economic and formal/informal institutions policies and laws, or roles, interests and priorities of rural men and women?</p> <p>Does the PDR identify the most important livelihood problems and opportunities faced by the community, as seen by women and men?</p> <p>Does the PDR include lessons learned on gender from previous IFAD or other partners' projects?</p>	<p>Does the PDR include lessons learned on changing gender norms at different levels from previous projects by IFAD or other partners/sources, or, at least how to go beyond usual GM?</p> <p>Were women's needs/challenges differentiated for different categories of women, or are women treated as a generic group?</p> <p>Note: the ops manual (2020) includes here the commitment to undertake the proWEAI assessment, IOE prefers to cover this criterion under the last dimension and link it to the allocation of budget to it.</p>	
Integration in ToC	Does the ToC address all three IFAD gender policy objectives (economic empowerment, equal voice and balanced workloads)?	<p>Does the PDR specify what exactly it aims to transform (what specific gender gaps) and showcase gender transformative pathways? (at which levels these changes are aimed²⁴⁹?</p> <p>Is there a focus on changing gender norms at the field level?</p> <p>Is there a plan for policy engagement on Gender Equality and Women's Empowerment (GEWE)?</p> <p>Does the project interventions address root causes of gender inequality using various GTA and/or engaging with men and boys to address the concepts of masculinity and gender?</p>	
Logical framework indicators	<p>Are disaggregated data included in the logframe for all target groups (by sex, disability status, age, other potential sources of discrimination)?</p> <p>Do the project logframe include indicators about % of men and women participating in project activities and/or receiving services promoted/supported by the project?</p>	<p>Inclusion of an adapted version of the pro-WEAI (i-WEAI) (or IFAD empowerment indicator as part of COI) as an additional impact indicator to measure change in women's empowerment.</p> <p>Does the gender analysis include key statistics about gender gaps for different project activities, so as to understand if a certain target is actually a transformative target?</p>	
Dedicated human and financial resources	<p>Does the PDR mention the inclusion of staff in the project management unit with gender-specific terms of reference?</p> <p>Does the PDR allocate funds to deliver gender-related activities?</p> <p>Does the PDR describe the project-level gender strategy/action plan to be developed or include key information about it?</p>	<p>Does the M&E section of the PDR include an explicit commitment to undertake the pro-WEAI assessment (or IFAD empowerment indicator as part of COI) at baseline and completion and allocate funds to do it?</p> <p>Does the PDR clearly describe the accountability mechanism to deliver the GT approach t?</p> <p>Is there a focus in the gender strategy on challenging or changing gender norms at different levels (e.g., at the field level, in institutions supporting smallholders? or in policy work or policy influencing work related to the project?</p> <p>Is there a deliberate effort to engage or work with the relevant gender ministry, or an important national entity that focus on gender issues in agriculture related areas? If yes, how²⁵⁰?</p>	

Source: modified by the evaluation team from the IFAD's operation manual (Annex VII. Mainstreaming guidelines for social inclusion themes), with inputs from ECG framework to analyse GT projects (2022)

²⁴⁹ Individual, household, community/rural institution, policies/legislation, national

²⁵⁰ Participation in the project steering committee, participation in the project kick-off meetings, advice on project gender strategy/action plan and its monitoring, any other.

Table 14
List of 16 project design reports reviewed.

<i>country</i>	<i>region</i>	<i>Short name</i>	<i>name</i>	<i>QAG gender rating</i>	<i>OPR/ECG validation as gender transformative project</i>
GT projects: rated 6 by QAG and validated as GT by OPR/ECG (3 projects met these criteria).					
China	APR	Y2RDP	Yunnan Rural Revitalization Demonstration Project	6	Yes
China	APR	H2RDP	Hunan Rural Revitalization Demonstration Project	6	Yes
Zimbabwe	ESA	SACP	Smallholder Agriculture Cluster Project	6	Yes
GT projects: rated 5 by QAG and validated as GT by OPR/ECG (5/23 projects purposefully selected, i.e., potential case studies, fragility status, and only 1 from NEN).					
Cambodia	APR	ASPIRE-AT	Agriculture Services Programme for an Inclusive Rural Economy and Agricultural Trade	5	Yes
Kenya	ESA	KeLCoP	Kenya Livestock Commercialization Project	5	Yes
Argentina	LAC	PROSAF	Promotion of Resilient and Sustainable Agrifood Systems for Family Farming Programme	5	Yes
Morocco	NEN	PRODER-Taza	Taza Mountain Integrated Rural Development Project for the pre-Rif Region	5	Yes
Cameroon	WCA	PADFA II	Commodity Value-Chain Development Support Project - Phase II	5	Yes
GM projects: rated 6 by QAG but not validated as GT by OPR/ECG					
Sri Lanka	APR	SARP	Smallholder Agribusiness and Resilience Project	6	No
Ethiopia	ESA	LLRP	Lowlands Livelihood Resilience Project	6	No
Cuba	LAC	PRODECAFE	Agroforestry Cooperative Development Project	6	No
Chad	WCA	RENFORT	Project to Strengthen Innovation in Youth and Women Agro-pastoral Entrepreneurship	6	No
GM projects: rated 5 by QAG but not validated as GT by OPR/ECG (4/24 projects purposefully selected, i.e., potential case studies and fragility status).					
India	APR	REAP	Rural Enterprise Acceleration Project	5	No
South Sudan	ESA	SSLRP	South Sudan Livelihoods Resilience Project	5	No
Brazil	LAC	PAGES	Amazon Sustainable Management Project (PAGES)	5	No
Sudan	NEN	SNRLP	Sustainable Natural Resources and Livelihoods Programme	5	No

This was complemented with the analysis of the **baseline reports of ten GT-projects approved since 2019**, to inform the real practice of the efforts to improve the rigor of measurement of IFAD’s projects contribution to women’s empowerment and to gender equality:

- (i) six related to the country case studies: **Tunisia** IESS Kairouan, **Cambodia** Sambaat, **Cameroon** PADFA II, **Kenya** KELCOP, **India** Tejaswini and **Argentina** PROSAF;
- (ii) additionally, the team reviewed the PDR of four additional GT projects: **China** H2RDP, **China** Y2RDP, **Zimbabwe** SACP and **Morocco** Proder-Taza, part of the analysis of PDR of projects with high gender ratings at design.

13. Climate change and gender analysis in IFAD operations

The deep dive on climate and gender examined the extent to which gender issues have been considered in IFAD’s projects that have a strong climate focus. Evidence was drawn primarily from the review of the IOE Thematic Evaluation of IFAD’s Support for Smallholder Farmers’ Adaptation to Climate Change carried out in 2020, which had 19 case studies, covering 37 projects in 20 countries (outlined in the Table below). The deep dive on climate change and gender also examined ASAP’s report on gender and climate change²⁵¹ and drew insights from a literature and document analysis.

Table 15
Projects evaluated by the Thematic Evaluation of IFAD’s Support for Smallholder Farmers’ Adaptation to Climate Change.

N°	Country	Project Name from 2010 to 2027	Approval date	Closing Date
1	Bangladesh	Coastal Climate Resilient No Infrastructure Project (CCRIP)	10/04/2013	31/03/2020
2	Belize	Resilient Rural Belize (Be-Resilient)	15/04/2018	30/06/2025
3	Bolivia	Economic Inclusion No Programme for Families and Rural Communities in the Territory of Plurinational State of Bolivia (ACCESOS-ASAP)	13/12/2011	31/03/2020
4	Burundi	Value Chain Development Yes Programme Phase II (PRODEFI-II)	15/09/2015	30/06/2022
5	Burundi	Agricultural Production Intensification and Vulnerability Reduction Project (PIPARV-B)	14/12/2018	31/12/2025
6	Cape Verde	Rural Socio-Economic Yes Opportunities Programme (POSER-C)	21/09/2012	30/09/2022
7	Chad	Project to Improve the Yes Resilience of Agricultural Systems in Chad (PARSAT)	01/12/2014	30/09/2022
8	Egypt	Sustainable Agriculture Yes Investments and Livelihoods (SAIL)	16/12/2014	31/12/2023
9	Ethiopia	Participatory Small-Scale No Irrigation Development Programme II (PASIDP-II)	22/09/2016	30/09/2024
10	Ethiopia	Lowlands Livelihood Resilience Project (LLRP)	12/09/2019	10/04/2026
11	Ethiopia	Pastoralist Community Development Programme III (PCDP III)	11/12/2013	08/11/2019
12	Ethiopia	Rural Finance Intermediation Programme II (RUFIP II)	15/09/2011	30/06/2021
13	Ethiopia	Community-Based Integrated Natural Resources Management Project (CBINReMP)	17/03/2010	31/03/2019
14	Honduras	Competitiveness & Yes Sustainable Rural Dev Project in Southwestern border Corridor (PRO-LENCA)	17/08/2013	30/09/2022
15	Kenya	Cereal Enhancement Yes Programme – Climate Resilient Agriculture Livelihoods Programme (KCEP-CRAL)	22/04/2015	31/03/2023

²⁵¹ <https://www.ifad.org/documents/38714170/46778436/asap-gender-climate.pdf/cf83a81b-2ebb-fb47-6719-fc93eed0f0ba?t=1668501560637>

16	Kenya	Upper Tana Catchment Natural Resource Management Project (UTaNRMP)	03/04/2012	30/06/2023
17	Kenya	Aquaculture Business Development Programme (ABDP)	11/12/2017	31/12/2026
18	Kenya	Programme for Rural Outreach of Financial Innovations & Technologies (PROFIT)	16/09/2010	31/12/2019
19	Kyrgyzstan	Livestock and Market Yes Development Programme I (LMDP)	17/12/2012	21/03/2020
20	Kyrgyzstan	Livestock and Market Development Programme II (LMDP II)	11/12/2013	30/09/2021
21	Madagascar	Project to Support Development in Menabe & Melaky Regions-Phase II (AD2M-II)	15/09/2015	30/06/2024
22	Mali	Fostering Agricultural Productivity Project (PAPAM)	16/10/2010	15/09/2015
23	Moldova	Inclusive Rural Economic and Climate Resilience (IRECR)	09/12/2013	30/09/2021
24	Moldova	Rural Resilience Project (RPP)	16/11/2016	31/03/2024
25	Nepal	Adaptation for Smallholders in Hilly Areas Project (ASHA)	13/09/2014	31/01/2023
26	Nicaragua	Adapting to Markets and Climate Change Project (NICADAPTA)	25/11/2013	30/06/2021
27	Niger	Family Farming Development Programme in the Diffa Region (ProDAF-Diffa)	29/09/2018	30/09/2025
28	Niger	Family Farming Development Programme in Maradi, Tahoua and Zinder Regions (ProDAF)	22/04/2015	31/03/2024
29	Niger	Ruwanmu Small-Scale Irrigation Project (Ruwanmu)	21/09/2012	31/12/2018
30	Niger	Food Security and Development Support Project in the Maradi Region (PASADEM)	13/12/2011	30/09/2018
31	Niger	Project to Strengthen Resilience of Rural Communities to Food and Nutrition Insecurity (PRECIS)	12/09/2019	31/03/2027
32	Rwanda	Climate Resilient Post-Harvest and Agribusiness Support Project (PASP)	11/12/2013	31/03/2021
33	Rwanda	Rwanda Dairy Development Project (RDDP)	22/09/2016	30/06/2023
34	Uganda	Project for Restoration of Livelihoods in the Northern Region (PRELNOR)	16/12/2014	30/09/2023
35	Sudan	Livestock Marketing and Resilience Programme (LMRP)	16/12/2014	30/09/2022
36	Sudan	Integrated Agricultural and Marketing Development Project (IAMDP)	11/12/2017	30/09/2024
37	Sudan	Sustainable Natural Resources and Livelihoods Programme (SNRLP)	12/09/2019	12/09/2026

The TE GEWE Evaluation Team reviewed the questions from the Evaluation Matrix in the Approach Paper for the TE GEWE and adapted some to incorporate climate change considerations as follows:

- Are climate change interventions properly designed to cater to the specific needs and priorities of different groups in building resilience?
- Does prioritizing adaptation to climate change overlook the needs of women?
- How is GEWE integrated with other mainstreaming themes (nutrition, climate change adaptation or youth-focused initiatives) at design? For instance, how does IFAD ensure that interventions support rural women's ability to adapt to climate change?

- Are adaptation efforts effectively addressing the needs of women?
- What is the value addition of the integration of both “mainstreaming themes”? Is climate action diluting the focus on gender?

Evidence was found mainly related to the relevance, effectiveness, knowledge management, and policy engagement aspects of the projects in the table above. No evidence was found on the impact, sustainability or scaling up of the projects. All evidence stemmed from the TE CCA evaluation and the ASAP report. Other initiatives funded by IFAD that address both climate and gender may be overlooked.

Evidence from the 11 of the 37 case studies suggests that the integration of gender and climate change adaptation is complementary to building the **resilience of women and addressing their specific needs and vulnerabilities**. The use of **SECAP** has been identified as a relevant approach to integrate gender and climate change (although correlation with various SECAP procedures updates is unclear).

ASAP-funded projects contributed to the three IFAD’s GEWE strategic objectives: women's empowerment, decision-making, and reduction of women's time burden. All the projects reviewed had a **gender-focused strategy or plan**, but limitations included actions starting late and not gaining traction throughout. Many projects targeted women-headed households, young people, and indigenous people. The **quota-based approach** has been shown to increase the participation of women and young people, but little is known about baselines. Consultations with communities and stakeholders demonstrated their effectiveness in **tailoring activities to meet the needs of women and targeting the poorest** and incorporating their needs into investments, and engaging communities in exploring resource management and adaptation. However, the TE on CCA highlighted the need to pay closer attention to the unique needs of different groups, e.g., pastoralists in sub-Saharan Africa. In Kenya (projects KCEP-CRAL, UTaNRMP, ABDP, PROFIT), Chad PARSAT, and Mali PAPAM, the inclusion of transhumant and their priorities for adapting to climate change was not sufficiently considered. The second-generation adaptation project in Burundi (PIPARV-B) showed how they took into account lessons from an earlier project (PRODEFI-II) to develop a more inclusive approach to women and indigenous people. PIPARV-B reports a growing embracement of CCA mainstreaming combined with a gender-sensitive approach.

In general, IFAD's approach to GEWE has limited information on its **alignment with national climate change adaptation plans** and should strive to integrate both climate change and gender considerations more consistently into projects designs and COSOPS. Examples were found however in Sudan and Rwanda (COSOP level), and the project-level in Honduras. Participative processes in Nepal ASHA and Sudan LMRP in the preparation of adaptation plans allowed space to incorporate the needs, challenges, and priorities of targeted rural communities and reduce their vulnerability.

Climate finance sources increasingly expect specific conditions or attention to gender aspects (GCF, GEF, AF and Gates Foundation). Research and interviews for the TE GEWE found that IFAD (and others such as UNDP, FAO, CGIAR) have developed materials to ensure a focus on gender equality and women’s empowerment for projects funded by climate funds. The TE on CCA found that **climate finance** played a role in introducing innovations, particularly in the areas of renewable energy, landscape/watershed approach, and use of the participatory approaches. It also stressed the importance of including non-lending operations for knowledge management and networking. The TE GEWE found that the **Gates Foundation grant to IFAD is encouraging innovation in applying GTAs**.

Ideas to reinforce the linkages between gender and climate at IFAD from TE GEWE:

- Ensure consistent attention to the implementation of **gender-transformative approaches in climate change adaptation initiatives**. This should start at project design, with a focus on household and institutional support levels.
- **All projects require some form of gender expertise, either through a gender focal point, gender and social inclusion specialist, or a contractual/partnership arrangement; all projects had some provision for gender training**. This is in line with what the ASAP report (2022) recommended.²⁵²
- **Ensure design teams address gender and climate change adaptation issues in parallel, and not treat them separately. Use SECAP assessment procedures** (and explore other materials coming from the Gates Funded GTM) to identify potential risks of excluding women and girls in CCA strategies and undermining their substantive equality by ignoring gender norms. Project designs require more targeted assessments of the CCA needs of women to ensure that projects address their vulnerabilities and build on their strengths (as expected in the GTA and GTM approaches).
- **To improve CCA targeting, strategies should:** set targets for female direct and indirect beneficiaries, making the most of women's and men's capacities in adapting to CCA, prioritizing geographical targeting where women are most vulnerable, and use methodologies such as the IFAD's Adaptation Framework Tool in selecting adaptation options (ASAP recommendation).²⁵³
- **IFAD should go beyond conventional approaches** that have been effective in meeting the needs of women, by implementing several gender-related recommendations from the Thematic Evaluation on CCA. These include diversifying income resources, promoting infrastructure and value chain development, and addressing land access issues to increase resilience to climate change. Strategies must be tailored. For example, implementing climate information services through examining women's specific information needs, promoting good practices for women's access to irrigation and integrating CCA into household methodologies. Thus, projects could ensure there is buy-in for gender transformative approaches at the service level (institutional level) moving beyond a household alone, so that projects can address financing and capacity issues in the implementation of GTAs.

14. Electronic survey

The information was collected anonymously using the computer-assisted self-interviewing method on the SurveyMonkey and was opened from May to September 2023. Two slightly different surveys were adapted to IFAD staff and to PMU staff. They were available in English, Spanish and French.

The list of IFAD staff from the PMD and consultants was provided by the Human Resources Department as of March 31, 2023²⁵⁴. PMU staff's contact information was collected and provided by respective IFAD regional representatives and focal points.

²⁵² The ASAP report stated there is a need to 1) establish a minimum goal for female beneficiaries and all people-based indicators; 2) include sex-segregated data; 3) enhance the inclusion of gender in project supervision, mid-term evaluations, and completion reports; and 4) have a gender specialist with CCA experience participate in missions.

²⁵³ "Repository of adaptation actions for small-scale agriculture, including livestock, forestry, and fisheries. It provides an approach for incorporating adaptation practices into project design. This framework uses a multi-criterion analysis system to allow project design teams to consider factors such as cost-benefit, climate-risk relevance, farmer capacities, mitigation co-benefits, and biodiversity support. Its selection of the best adaptation measures is informed by analysis of climate change risks and impacts. It also provides a rationale that can be used in mobilizing climate finance."

²⁵⁴ **PMD staff** are those with an indefinite appointment on all funding sources with the following roles: Country directors, Country programme officers (or programme officers), Country programme analysts (or programme analysts), regional economists, regional portfolio advisors, Junior Professional Officers. **Consultants** are those hired in PMD with at least one contract of minimum three months in the past 5 years.

Despite various attempts by the evaluation team, contact information for PMU staff working in some countries and therefore they were not included in the survey²⁵⁵.

Table 16
Response rates by type of survey and different subgroups of respondents

	<i>Targeted respondents (Survey universe)</i>	<i>Respondents (complete survey, used for analysis)</i>	<i>Analysis of overall response rate</i>
PMD survey	695: 142 staff (20%) and 553 long-term consultants (80%)	178: 69 staff and other (39%) and 109 long-term consultants (61%) ²⁵⁶	26% <ul style="list-style-type: none"> The number of responses is too low to make a separate analysis for the two subtypes of PMD respondents. It is likely that some consultants are no longer working for IFAD and were not motivated to answer.
PMU survey	1414: 690 from APR (49%), 285 from ESA (20%), 177 from LAC (13%), 177 from WCA (13%); 85 from NEN (6%)	561: 180 from APR (32%), 149 from ESA (27%), 94 from LAC (17%), 91 from WCA (16%), 43 from NEN (8%) ²⁵⁸ . Additional 4 indicated working on global level (1%) ²⁵⁹	40% <ul style="list-style-type: none"> The respondents to the PMU survey are skewed towards APR reflecting the list of PMU staff emails received.

The **characteristic of respondents** to both surveys is similar (skewed towards males), around 42%-43% with five or more years of experience working with IFAD. In terms of regional representation, the percentage of PMD respondents was mostly similar across APR, LAC, WCA and ESA. For the PMU survey, respondents from APR represent a 32%, followed by 27% from ESA. NEN respondents were less than 10% for both surveys (7% in PMD; 8% in PMU).

The following **ordinal scale was used to measure respondents' attitudes toward various aspects of GEWE at IFAD**: 1 = Strongly Disagree; 2 = Disagree; 3 = Moderately Disagree; 4 = Moderately Agree; 5 = Agree; 6 = Strongly Agree; 0 = Don't know. When reporting key survey responses in the main text, options 1-3 and 4-6 are presented cumulatively to report the level of support or agreement with the selected survey items. Percentages are calculated without the "don't know" response option. In case of high "don't know" proportions, this fact is also reported in the respective parts of the text.

To determine if there were **statistically significant differences in answers between different subgroups of respondents**, statistical significance tests were conducted (Mann-Whitney U test; independent samples t-test; Chi-squared test; One-way ANOVA). Comparisons between different subgroups of respondents are only reported if the differences are statistically significant and the number of responses by various groups is sufficient.

E-survey questionnaire for IFAD operational staff:

Questions for IFAD operational staff and consultants

IFAD staff (country directors/country programme officers/country programme analysts/regional economists and regional portfolio advisors)

²⁵⁵ The contact information of PMU staff for the following countries was not received: LAC – Mexico, Guatemala, Honduras, Colombia; NEN – Lebanon; APR – Afghanistan, Myanmar, Indonesia, Papua New Guinea; WCA – Congo, Chad, Niger, Nigeria, Cameroon, Togo, Ghana, Côte d'Ivoire, Guinea, Gambia, Senegal, Cabo Verde.

²⁵⁶ 283 agreed to participate in the survey and answered the first question of the questionnaire, but in the end, only 178 eligible respondents provided complete valid responses. Their answers to the first questions are considered in the analysis.

²⁵⁷ This was calculated using the self-reported information by respondents to the e-survey. "Other" means "not listed in the original answer options".

²⁵⁸ 770 of the 1414 respondents started the survey, but only 561 respondents provided complete responses.

²⁵⁹ This was calculated using the self-reported information by respondents to the e-survey.

IFAD long-term consultants (those not covering social inclusion /gender aspects)

Respondent information

1. Which of the following best describes your position in IFAD?

For IFAD staff/consultant

- IFAD Staff – country director
 - IFAD Staff – country programme officer
 - IFAD Staff – country programme analyst
 - IFAD staff- regional economist/regional portfolio advisor
 - IFAD Consultant supporting operations
 - Other (please specify)
2. Which region is the major focus of your IFAD-related work?
 - Asia and the Pacific
 - East and Southern Africa
 - Near East, North Africa and Europe
 - Latin America and the Caribbean
 - West and Central Africa
 - Global level
 3. Gender
 - Female
 - Male
 - Other
 - Prefer not to say
 4. How long have you been working for IFAD (cumulatively, even with interrupted record)?
 - Less than 2 years
 - 2 to 4 years
 - 5 to 10 years
 - More than 10 years
 5. What is your primary place of IFAD job/where are you based?
 - Headquarters (Rome)
 - Field
 - Working remotely / from home
 - Other

1. Awareness, motivation and capacity to work on GEWE.

Please indicate your agreement and disagreement with the following statements (1 – Strongly disagree, 2 – Disagree, 3 – Moderately disagree, 4 – Moderately agree, 5 – Agree, 6 – Strongly agree, 0- I don't know)

- I have a good understanding of the IFAD 2012 Gender Policy.
- I have a good understanding of the IFAD 2019 Action Plan on mainstreaming gender transformative approaches.
- I have little understanding of how to integrate gender equality and women's empowerment in a project's activities.
- I have a good understanding of the difference between a gender mainstreaming and gender transformative project.
- There is consistency and conceptual clarity in the use of gender-related terms across IFAD.
- There is an issue regarding the translation of key gender-related concepts to other languages.
- IFAD's approach and/or methodologies to GEWE are adaptable in different cultural context.

- I have taken a training course and/or studied how to promote gender equality and women's empowerment in development programmes in the last 5 years.
- IFAD Gender Awards are a good tool to boost motivation of IFAD operations staff and project management unit staff to improve GEWE results and impact.
- I am motivated to work on GEWE.
- I do not have adequate time to work on GEWE.
- GEWE objectives/results are not reflected in my performance evaluation and are not discussed with my supervisor.
- My supervisor demonstrates commitment to achieving gender equality objectives in IFAD operations.
- *Please use this space to share any comment/nuance to your responses to this question.*

2. Factors influencing GEWE performance in IFAD operations

Please rate the factors that you consider influence GEWE performance in IFAD operations from the most important factor (1) to the least important factors (up to 10), according to your experience. Please, drag and drop statements in the order of preference.

Factors that influence GEWE performance:

- Good quality gender, poverty and livelihood analyses informing the whole project design.
- Inclusion of a project-gender strategy/action plan at design or at the very early stages of project start-up.
- GEWE budget incorporated into the project design.
- IFAD gender/social inclusion expert (staff or consultant) participating in most or all missions from design (and early implementation) to closing.
- Availability of resources for gender activities during implementation in order to implement the gender strategy.
- A gender expert in the project management unit.
- Ownership of the project gender strategy or action plan by the Project Management Unit, senior staff and other project implementers.
- Existence of national regulatory and legislative environment conducive to gender equality.
- Gender as part of COSOP objectives or clear explanation of how to promote GEWE in the COSOP.
- Level of income or fragility status or overall gender inequality level in the country.
- *Please explain your choice, giving examples of when these factors played a key role in IFAD's performance towards Gender Equality and Women's Empowerment, or flag any other key factor affecting GEWE performance in IFAD operations.*

3. Relevance and effectiveness of IFAD's corporate approach to gender

Please indicate your agreement and disagreement with the following statements (1 – Strongly disagree, 2 – Disagree, 3 – Moderately disagree, 4 – Moderately agree, 5 – Agree, 6 – Strongly agree, 0- I don't know)

- IFAD senior managers demonstrate commitment to the promotion of gender equality and women's empowerment in IFAD operations.
- IFAD GEWE approach is hard to adapt to the priorities of different groups of men and women in various implementation contexts.
- The level of detail and quality of the COSOP and project-level gender strategies at design stage is sufficient to guide implementation.
- The IFAD integrated approach (mainstreaming gender with youth, nutrition and environment and climate change) is well-accepted by partner governments and easily implemented.

- IFAD has adequate resources to reach GEWE targets included in IFAD replenishments (% of projects 4+ and 5+ on GEWE at design and at completion, % of projects rated Gender Transformative at design).
- *Please use this space to share any comment/nuance to your responses to this question.*

4. Available guidance and support to work on GEWE.

Please indicate your agreement and disagreement with the following statements (1 – Strongly disagree, 2 – Disagree, 3 – Moderately disagree, 4 – Moderately agree, 5 – Agree, 6 – Strongly agree, 0- I don't know):

- I know where to find resources and information on GEWE, including guidance and tools.
- IFAD GEWE resources are not available in the language needed.
- I have received adequate capacity building on GEWE to understand IFAD requirements.
- I have received adequate capacity building on GEWE to convey the message to national implementing partners.
- I receive sufficient support on gender from IFAD gender and social inclusion staff to support project design.
- Actions proposed by IFAD gender and social inclusion specialists during projects implementation support or supervision missions are useful to improve GEWE performance.
- There are sufficient financial resources to hire gender experts to go on project design missions.
- There are insufficient financial resources to hire gender experts to go on supervision missions.
- There are sufficient financial resources to hire gender experts to go on mid-term review missions.
- *Open question: what other factors supported and/or hindered your work on Gender Equality and Women's Empowerment at IFAD?*

5. Measurement of IFAD operations' contribution to gender equality and women's empowerment

Please indicate your agreement and disagreement with the following statements (1 – Strongly disagree, 2 – Disagree, 3 – Moderately disagree, 4 – Moderately agree, 5 – Agree, 6 – Strongly agree, 0- I don't know)

- The gender marker to assess gender sensitivity (indicated in the IFAD Operations Manual) is applied systematically across the project cycle.
- The IFAD system to measure the performance of GEWE can be tailored to different implementation contexts.
- The current M&E system is insufficient to monitor GEWE results towards IFAD's first gender strategic objective (economic empowerment).
- The current M&E system is insufficient to monitor GEWE results towards IFAD's second gender strategic objective (more equal representation and women's voice).
- The current M&E system is insufficient to monitor GEWE results towards IFAD's third gender strategic objective (reducing workloads and fairer distribution of benefits).
- Quotas set for male/female involvement in project activities are sufficient to assess GEWE performance in IFAD operations.
- It is not possible to measure women's and men's access to certain goods and services provided by the project.
- I understand what should be measured in IFAD Gender Transformative projects.
- Technical expertise to measure gender transformative changes is available in the country where I work.

- *Please use this space to share any comment/nuance to your responses.*

6. Non-lending activities yielding GEWE results

Please indicate your agreement and disagreement with the following statements (1 – Strongly disagree, 2 – Disagree, 3 – Moderately disagree, 4 – Moderately agree, 5 – Agree, 6 – Strongly agree, 0- I don't know)

- I have seen COSOPs identify strategic partnership opportunities on GEWE.
- Gender-focused grants and supplementary funds are not strategically used to enrich the results of investment programmes/projects.
- The current M&E and knowledge management systems are able to capture good GEWE practices.
- Good GEWE practices are shared with relevant IFAD stakeholders.
- I have sufficient knowledge and support to engage in national policy dialog on GEWE.
- I have seen cases when IFAD acted as a catalyst for national policy engagement on GEWE.
- I have the resources to promote scaling up of IFAD-promoted GEWE interventions to partners.
- *Please use this space to share examples and describe how IFAD non-lending activities have yielded gender results.*

7. Gender equality and diversity in the workplace

Please indicate your agreement and disagreement with the following statements (1 – Strongly disagree, 2 – Disagree, 3 – Moderately disagree, 4 – Moderately agree, 5 – Agree, 6 – Strongly agree, 0- I don't know)

- My supervisor is committed to supporting gender equality internally within IFAD.
- IFAD's organizational culture is supportive of staff and consultants of my gender.
- IFAD's organizational culture values women in leadership.
- Teleworking arrangements positively contribute to my work-life balance.
- My work unit is taking action to improve or ensure diversity among staff members.
- Women in IFAD are paid the same as men for the same work or work of equal value.
- Women have equal say as men during decision-making processes in IFAD.
- *Please use this space to share any comment/nuance to your responses to this question.*

8. Any lessons/insights you would like to share on how IFAD should be organized (in terms of human resources, financial resources, or internal procedures) to improve its promotion of GEWE?

Questions for PMU operational staff and consultants:

Project Management Unit (PMU) staff at various levels (national level; if emails available regional/district, local)

PMU gender/social inclusion specialists at national level

PMU staff in charge of gender/social inclusion at subnational/local level (even if covering other aspects)

Other PMU staff (project manager, technical expert, component manager, other- include space to answer which (title/work at national/regional/local level) –

Respondent information

Gender/social inclusion project staff – National level

Gender/social inclusion project staff at subnational level (regional/district/local level), if applicable

Other PMU staff at national level (project manager, technical expert, component manager, other)

Other PMU project staff at subnational -regional/district level (project manager, technical expert, component manager, other)

Please specify your title

In which region do you work?

Asia and the Pacific

East and Southern Africa

Near East, North Africa and Europe

Latin America and the Caribbean

West and Central Africa

Global level

Gender

Female

Male

Other

Prefer not to say

How long have you been working for IFAD-supported projects?

Less than 2 years

2 to 4 years

5 to 10 years

More than 10 years

Awareness, motivation and capacity to work on GEWE in your project

Please indicate your agreement and disagreement with the following statements (1 – Strongly disagree, 2 – Disagree, 3 – Moderately disagree, 4 – Moderately agree, 5 – Agree, 6 – Strongly agree, 0- I don't know)

The promotion of gender equality and women's empowerment is relevant to my work with IFAD.

I have a good understanding of the IFAD 2012 Gender Policy.

I have a good understanding of the IFAD 2019 Action Plan on mainstreaming gender transformative approaches.

There is an issue of translation of key gender-related concepts to other languages.

IFAD's approach and/or methodologies to GEWE are adaptable in different cultural contexts.

I have a good understanding of the IFAD gender marker system (ratings from 1 to 6 on GEWE performance of the project from design to completion).

I do not fully understand what a gender transformative project is.

The PMU staff in charge of gender (and/or social inclusion issues) has enough seniority and knowledge to influence decisions.

Gender is the responsibility of all Project Management Unit staff.

The PMU staff in charge of gender (and/or social inclusion issues) does not receive adequate support from PMU management.

I am motivated to work on GEWE in the project.

I have sufficient time to work on GEWE in the project.

I have taken a training course and/or studied how to promote gender equality and women's empowerment in development programmes in the last 5 years.

IFAD Gender awards are a good tool to boost motivation of IFAD operations staff and PMU staff to improve GEWE results and impact.

Please use this space to share any comment/nuance to your responses to this question.

Factors influencing GEWE performance of IFAD operations

Please rate the factors that you consider influence GEWE performance in IFAD operations from the most important factor (1) to the least important factors (up to 10). Please, drag and drop statements.

Factors that influence GEWE performance:

Good quality gender, poverty and livelihood analyses to inform the whole project design. Inclusion of a project-gender strategy/action plan at design or at the very early stages of project start-up.

GEWE budget incorporated into the project design.

IFAD gender/social inclusion expert (staff or consultant) participating in most or all missions from design (and early implementation) to closing.

Availability of resources for gender activities during implementation to implement gender strategy.

A gender expert in the project management unit.

Ownership of the project gender strategy or action plan by the Project Management Unit and other implementers.

Existence of national regulatory and legislative environment conducive to gender equality.

Gender as part of COSOP objectives or clear explanation of how to promote GEWE in the COSOP.

Level of income or fragility status or overall gender inequality level in the country.

Please explain your choice, giving examples of when these factors played a key role in IFAD's performance towards Gender Equality and Women's Empowerment, or flag any other key factor affecting GEWE performance in IFAD operations.

Available guidance and support to work on GEWE.

Please indicate your agreement and disagreement with the following statements (1 – Strongly disagree, 2 – Disagree, 3 – Moderately disagree, 4 – Moderately agree, 5 – Agree, 6 – Strongly agree, 0- I don't know)

I know where to find resources and information on IFAD GEWE, including guidance and tools.

IFAD GEWE resources are not always available in the language needed.

I have received adequate information and training on GEWE to understand IFAD requirements.

Actions proposed by IFAD gender and social inclusion specialists during projects implementation support or supervision missions are useful to improve GEWE performance.

IFAD gender and social inclusion experts are available to provide adequate support on GEWE when I need it.

Financial resources are clearly allocated to gender-specific activities.

Open question: what other factors supported and/or hindered your work on GEWE at IFAD?

Measurement of IFAD operations' contribution to gender equality and women's empowerment

Please indicate your agreement and disagreement with the following statements (1 – Strongly disagree, 2 – Disagree, 3 – Moderately disagree, 4 – Moderately agree, 5 – Agree, 6 – Strongly agree, 0- I don't know)

The IFAD system to measure the performance of GEWE can be tailored to different implementation contexts.

The current M&E system is insufficient to monitor GEWE results towards IFAD's first gender strategic objective (economic empowerment).

The current M&E system is insufficient to monitor GEWE results towards IFAD's second gender strategic objective (more equal representation and women's voice).

The current M&E system is insufficient to monitor GEWE results towards IFAD's third gender strategic objective (reducing workloads and fairer distribution of benefits).

Quotas set for male/female involvement in project activities are sufficient to assess GEWE performance in IFAD operations.

It is not possible to measure women's and men's access to certain goods and services provided by the project.

I understand what should be measured in IFAD Gender Transformative projects.

Technical expertise to measure gender transformative changes is available within my country.

Please use this space to share any comment/nuance to your responses to this question or provide examples.

Any lessons/insights you would like to share on how IFAD should be organized (in terms of human resources, financial resources, or internal procedures) to improve performance towards GEWE?

Interviews – see list in annex XXVII

Follow-up of the implementation of the 2010 IOE corporate-level evaluation on gender

Table 17

Assessment of the advance on recommendations from 2010 CLE on IFAD's performance with regard to GEWE

Recommendations from 2010 IOE CLE	Management Responses	IOE Assessment by the TE on GEWE in 2023
<ul style="list-style-type: none"> · Develop an evidence- and results-based corporate policy on GEWE. GEWE policy to cover both operational and corporate business processes and results measurement framework for IFAD's gender work. · GEWE policy to include a section on responsibilities for implementation, oversight and reporting and indicate how the EB will fulfil its role in providing guidance and support on gender issues. 	<ul style="list-style-type: none"> - Overarching evidence- and results-based corporate policy and implementation strategy on gender will be developed by Management and submitted to the EB in 2011, covering both operational and business processes - Development of a better set of indicators to measure impacts and results in GEWE 	<ul style="list-style-type: none"> - IFAD's gender policy approved in 2012, gender action plan (GAP) guided gender work from 2016 (4-paged Gender mainstreaming in IFAD10). In 2019, a specific GAP to mainstream gender transformative approaches approved, in parallel to an integrated framework to mainstreaming themes. Operational and corporate business processes covered by the gender policy and GAPs, while gender parity and diversity issues (action area 4 of the policy) handled by the human resources division since 2018. - Results measurement framework: specific annex in RIDE covers IFAD's performance on gender, completed by a stand-alone report on mainstreaming themes (RIME) in 2023. Key indicators in the Results Management Framework are not fit for purpose, skewed towards outputs. Ongoing confusion about what to measure in relation to the GT-validated projects. - Oversight by specific senior management level mechanism and the Board expected in the gender policy did not materialize. The 2016 mid-term review of the policy stated that this was provided by the existing Operations Management Committee. However, the evaluation did not find evidence that senior management level committees provide sufficient strategic guidance and oversight on gender. Accountability mechanisms for gender and diversity balance improved with the 2021 Strategy on diversity, equity and inclusion.
<ul style="list-style-type: none"> · Knowledge management, learning and analytic work. IFAD needs to invest in building a common evidence-based understanding among staff of the theory of gender equality and women's empowerment, and its related terminology. 	<ul style="list-style-type: none"> - IFAD will seek to improve its capacity to learn more about GEWE through existing and new knowledge management and learning processes. - Management believes that it is important to develop a common understanding in IFAD of basic principles and gender-related concepts. 	<ul style="list-style-type: none"> - Training efforts and new guidance produced (along with gender glossaries in 2012 and 2021), but the multiplicity of gender-related changes in IFAD since 2016 was too high for ensuring uptake and common understanding among all stakeholders in charge of designing and implementing gender approaches in IFAD operations at various levels. Widespread deficiencies in project M&E systems hamper the possibility to transform tested gender approaches into shareable knowledge.
<ul style="list-style-type: none"> · Innovation and scaling up as key principles. IFAD to include GEWE as one of the "big bets" in IFAD's corporate innovation agenda, promoting gender-related innovations at the country/project level and efforts to scale up successful innovation for a wider GEWE impact. 	<ul style="list-style-type: none"> - IFAD will also support innovative approaches and their scaling up, by building partnerships with regional knowledge centres of excellence on this theme 	<ul style="list-style-type: none"> - Gender grants and joint programmes have tested innovative approaches, building on strategic partnerships. However, their scale up and integration in IFAD's portfolio at country level has been challenging in many contexts. This also applies to GEWE practices such as household methodologies and Cerrando Brecha, with some exceptions in some countries.
<ul style="list-style-type: none"> · Policy dialogue and advocacy work to be focused in specific 	<ul style="list-style-type: none"> - In the development of its new policy on gender [2012], IFAD will invest more in managing knowledge, 	<ul style="list-style-type: none"> - Key IFAD operational staff have not received specific training to engage in policy dialogue on GEWE. New GT-validated projects include the intent in their designs, but it is not clear how to

<p>thematic areas in a given country context. Competencies and skills of staff to be enhanced and continued attention to partnerships with multiple stakeholders for advocacy at global and country levels.</p>	<p>enhancing learning and undertaking analytic work, and engaging in policy dialogue and advocacy related to gender issues, both directly and through enhanced partnerships</p>	<p>measure results. Partnerships have been fruitful with the UN Rome-based agencies, especially through joint programmes. Other partnerships have been ad-hoc and with limited documentation on their results and value added.</p>
<p>Recommendations from 2010 CLE</p>	<p>- Management Responses</p>	<p>- IOE Assessment in 2023</p>
<p>IFAD's gender architecture. Conduct a review of IFAD's overall gender architecture, not only of the Programme Management Department but all other departments in the organization²⁶⁰.</p>	<p>- IFAD will undertake a comprehensive review of IFAD's overall gender architecture, including oversight functions at the Management level; required profiles, location and numbers of dedicated gender positions in the Programme Management Department and other divisions, including the Human Resources Division; redefinition of the role of gender focal points and allocation of adequate resources for this function; and role and structure of the Thematic Group on Gender</p>	<p>- Management conducted a comprehensive review of IFAD's overall gender architecture in 2011. The policy provided a clear structure of the gender architecture involving the gender and social inclusion team, regional gender staff, gender focal points and the appointment of a senior gender champion. The gender architecture was supported by gender communities of practice and gender consultants. Human resources in the gender and social inclusion team have increased since then, but not at the same pace as the increase in workload. The number of gender focal points increased, but in recent years they play a minor role in the gender architecture. Less importance has been put on the role of different parts of the gender architecture to fulfil GEWE commitments in the 2019 action plan compared to previous corporate documents.</p>
<p>Tracking investments and budgets. Management to undertake an analysis of spending on GEWE based on a sample of projects with good gender equality results. Efforts should be made to indicate the GEWE resources as part of the Fund's annual results-based programme of work and administrative budget.</p>	<p>- IFAD will seek better ways to track the resources allocated to gender to do this.</p>	<p>- Systems to track core budget resources to support gender-related work developed but they require improvement: allocations of staff time spent on gender need updating, time spent by consultants on gender not considered; and methodology to track ex-ante gender sensitivity of loans and grants not yet standardized enough. No clear link with results and budgeting discussions and processes, as done in other organizations such as UNDP. - Information about budget and actual costs for gender in projects are scant and unsystematic.</p>
<p>Training. While gender-specific training and awareness-training is needed on key concepts, it is also recommended that a gender perspective be incorporated in training events organized by PMD on operational aspects and by the HRD on core competencies and in staff induction programmes.</p>	<p>-</p>	<p>- Consistent efforts from HRD and gender team since 2016 (inclusion in corporate induction webinar, mandatory training for new staff and non-staff, regional clinics on gender, support to project start-up). No gender training for senior managers available, as done by UNDP and advised by UNSWAP.</p>

²⁶⁰ The evaluation recommended a comprehensive review of IFAD's gender architecture (within the Programme Management Department (PMD), where the gender and social inclusion team was located at the time, as well as in other divisions) to ensure the Fund had the required human resources and funds to achieve the desired results in borrowing countries. In particular it noted inadequate resources for the gender team to support learning and KM in the regional divisions, a less influential internal thematic group on gender over time and an unclear role for divisional gender focal points.

- Assessment of GEWE in evaluations. It is recommended that IOE develop specific indicators and key questions for assessing GEWE in country programme and project evaluations, and a dedicated section in all evaluation reports. The same for IFAD's self-evaluation system.
 - IFAD will also strengthen corporate reports such as the Report on IFAD's Development Effectiveness (RIDE) to report on its gender performance
 - IOE has included a stand-alone GEWE evaluation criterion in all evaluation products since 2011. Also included in the updated IFAD evaluation manual (2022), covering both self-evaluations and independent evaluations. However, there are still issues with the availability and quality of robust evidence on gender outcomes.
-

Table 18
Assessment of the advance on recommendations from 2017 IOE Evaluation Synthesis on what works for GEWE- a review of practices and results.

<i>Recommendations from 2017 ES</i>	<i>Management Responses</i>	<i>IOE Assessment by the TE on GEWE in 2023</i>
<p>Recommendation 1. Conceptualize and integrate the gender transformative approach for use throughout the organization for IFAD10.</p>	<p>- Management fully agrees with the need to conceptualize the gender transformative approach and develop a shared understanding of processes and practices. [...] In line with the Sustainable Development Goal agenda, IFAD set targets not only to increase the proportion of projects where gender is mainstreamed, but also to make interventions more transformative. Under IFAD10, it is suggested that 15 per cent of projects should be gender-transformative and 90 per cent of projects rated as partial gender mainstreaming (moderately satisfactory = 4) or better on completion. [...] Clear definitions, benchmarks and indicators are needed, also for reporting under IFAD10.</p>	<p>- This has been patchily done. The multiplicity of gender-related changes, including the ones related to the use of GTAs in IFAD operations and the difference with GT programming, has been too high for ensuring uptake and common understanding. The various guidance is not compiled in a consolidated package in all UN languages.</p>
<p>Recommendation 2. Develop explicit theories of change to underpin targeting strategies for different groups of women, together with indicators to monitor them at the point of design, and offer tailored interventions based on available good practices.</p>	<p>- Management agrees [...] theories of change allow for more explicit articulation of the necessary steps from inputs to achieving desired outcomes and impacts, also in promoting gender equality and women's empowerment. Moreover, the implementation of IFAD's development effectiveness framework – and strengthening of monitoring and evaluation (M&E) capacity through the CLEAR grant initiative – are particularly timely to train IFAD staff and build the capacity of project staff and others in developing countries in the application of theories of change for better gender and other results on the ground.</p>	<p>- No consistent efforts have been found to develop theories of change and clear pathways to achieve gender results. Efforts to build M&E on gender have been more limited than needed, in addition to regular gender training.</p>
<p>Recommendation 3. Establish systematic M&E of disaggregated benefits and GEWE outcomes at corporate and project levels.</p>	<p>- [...] the ongoing CLEAR grant initiative should help, as well as the efforts to refine IFAD's Results and Impact Management System (RIMS) to be discussed with the Board in April 2017 – which includes strengthening gender indicators that are regularly monitored at the project level and reported for enhanced results management and learning. Similarly, key elements of the Women's Empowerment in Agriculture Index (WEAI), which measures the empowerment, agency and inclusion of women in agriculture dimensions, are being carefully built into the design of project impact assessments being done as part of the IFAD10 initiative on impact assessments, to better attribute the results to IFAD operations. IFAD has also developed a methodology to take gender considerations into account in IFAD's loan portfolio and the regular budget. Two separate methodologies were developed in 2013 for: (i) conducting an ex-ante analysis of gender sensitivity in IFAD loans; and (ii) identifying distribution of the regular budget for gender-related activities.</p>	<p>- Revision of RIMS yielded the Corporate Outcome Indicators framework (and guidelines). In COI, in addition to sex disaggregation of most of indicators, there is a specific indicator on empowerment, which is based on pro-WEAI. However, not clear if the IFAD empowerment indicator is able to capture the differential impacts on rural men and women participating in an IFAD-supported project/programme. In addition, there is ongoing confusion between the IFAD empowerment indicator to be calculated for GT-validated projects and the measurement conducted by RIA of completed projects (using the integrated-WEAI, I-WEAI). Currently, some indicators of the I-WEAI are also built-in all RIA impact assessments.</p> <p>- Methodology to track gender budget and gender sensitivity of IFAD loans analysed above.</p>

<i>Recommendations from 2017 ES</i>	<i>Management Responses</i>	<i>IOE Assessment in 2023</i>
<p>Recommendation 4. Report consistently on GEWE outcomes and impacts in GEWE evaluations and include sound contextual analysis to explain results (IOE)</p>	<p>- Management welcomes the proposal for independent evaluations to better capture gender outcomes and impact, including deeper explanations of the proximate causes of good or less good performance. This will contribute to promoting accountability and learning throughout the organization</p>	<p>- IOE includes a stand-alone GEWE evaluation criterion in all evaluation products as per the updated IFAD evaluation manual (2022). UNSWAP reporting on the evaluation indicator is exceeding requirements, but IOE continues to hold technical discussions after the review of evaluations to improve how gender is incorporated throughout the evaluation cycle.</p>
<p>Recommendation 5. Replicate good practices covering the three GEWE policy objectives and strengthening working with men.</p>	<p>- There are good experiences on promoting gender equality and women’s empowerment in all sectors, in particular on rural finance, improving agricultural production and access to markets and diversification of income-generating opportunities. Reducing rural women’s workload is one of three pillars of IFAD’s gender policy. The GEWE approach can be strengthened in infrastructure development, from roads, water and sanitation, irrigation to energy and warehouses. Only once women have more available time will they be able to engage more in economic activities and community matters. The involvement of men is a priority for IFAD as demonstrated in its efforts to promote participatory methods targeting all household members. IFAD has pioneered household methodologies, which have been included in the design of more than 40 new projects. [...] IFAD is trying to encourage reflections on the contextual circumstances of any development intervention. However, within the well-defined set-up of an investment project it might be not possible to give enough attention to the review of systematic issues, unless it is accompanied by a research programme. IFAD is continuously collecting evidence from its operations to further define drivers and pathways for scaling up GEWE and how those can be set in motion and sustained in a project. Potential gender-sensitive innovations for scaling up need to be identified at the design stage and monitored throughout.</p>	<p>- The TE analysed common GEWE practices, aligned to the three GEWE policy objectives, and also covering cases where rural men were purposely involved for more gender equality. However, project M&E are still weak in consistently reporting GEWE practices promoted and analysing the benefits, going beyond outreach (men/women quota data). Results of HHM (GALS) are not well integrated in project M&E and are weakly reported and analysed.</p>

IFAD GEWE action areas and indicators, replenishment commitments and SDG 5 targets alignment.

Table 19
Indicators included in the 2012 Gender Policy (*), 2016 mid-term review () and 2019-2025 GAP (***)**

<i>Action areas</i>	<i>GEWE outcome Indicators</i>
1. IFAD-supported country programmes and projects	<ul style="list-style-type: none"> - Proportion of loans and grants with gender-specific objectives supported by clear budget allocations* ²⁶¹ <ul style="list-style-type: none"> - Projects with GEWE rating 4+ at design - Project with GEWE rating 6 (gender transformative/highly satisfactory) at design** - Proportion of new COSOPs and CSNs (in IFAD11) which are gender mainstreamed*** <i>Additionally, the 2019 GAP includes output indicators</i>²⁶².
2. IFAD as a catalyst for advocacy, partnerships and knowledge management	<ul style="list-style-type: none"> - Number of IFAD inputs on gender issues in international forums and publications* <ul style="list-style-type: none"> - References to GEWE in key IFAD policy documents and knowledge products* <ul style="list-style-type: none"> - Focus on gender issues in policy dialogue and scaling up* - Number of joint gender-related initiatives with other development agencies* - Number of substantive references to gender issues in agricultural and rural development by IFAD Management in public forums and the media* <ul style="list-style-type: none"> - Number of corporate events focused on gender*** <i>Additionally, the 2019 GAP includes output indicators</i>²⁶³.
3. Capacity-building of implementing partners and government institutions	<ul style="list-style-type: none"> - Number and quality of initiatives to support GEWE undertaken by government institutions* ²⁶⁴ <ul style="list-style-type: none"> - Projects with GEWE rating 4+ ** and 5+ at completion*** - Percentage of women reporting improved quality of their diets *** <i>Additionally, the 2019 GAP includes output indicators</i>²⁶⁵.
4. Gender and diversity balance in IFAD	<ul style="list-style-type: none"> - Women in P-5 posts and above ** - Scores on gender-related staff survey questions by both women and men <p><i>* Note: Action area 4 is excluded in the 2019 GAP since it is covered by HRD in the 5 R Gender Action Plan to improve gender parity in IFAD.</i></p>
5. Resources, monitoring and professional accountability	<ul style="list-style-type: none"> - Human and financial resources from IFAD's core budget invested to support GEWE* ²⁶⁶ <ul style="list-style-type: none"> - Scores on the annual review of IFAD's performance on GEWE* - Amount of additional funds supporting implementation of the GAP*** <i>Additionally, the 2019 GAP includes output indicators</i>²⁶⁷.

²⁶¹ This indicator is operationalised in RIDEs through: (i) Proportion of loans and grants value approved with a gender dimension or with a strong gender focus (RIDE 2013 & 2014). From 2015, this indicator is measured with the proportion of loans and grants value with specific gender ratings (gender sensitivity analysis).

²⁶² The 2019 GAP includes the following output indicators for the first action area: Number of comprehensive **guidelines and procedures** to mainstream gender developed/updated; number of **IFAD Management and staff trained** in GEWE (disaggregated by sex); number projects with **gender and social inclusion experts** participating in design, supervision and implementation-support **missions**; number of new projects with **core indicators on GEWE included in their logframes**.

²⁶³ The 2019 GAP includes the following output indicators for the second action area: Number of **communication and advocacy strategies** developed; number of gender-focused knowledge management products developed; number of **cofinanced investment projects** in agricultural and rural development with a gender focus.

²⁶⁴ The policy includes as examples policies supportive of women's entitlement to land and other assets, ministries of agriculture and rural development with senior gender expertise/gender unit and gender strategy, public investment in domestic water supplies. However, many editions of the RIDE do not report specific initiatives, but rather occasional government initiatives.

²⁶⁵ 2019 GAP includes output indicators: Number of government representatives and other implementation partners trained (disaggregated by sex); Number of downloads of IFAD's how-to-do notes on gender for design and implementation; Number of training tools developed or revised, including IFAD Operations Academy; Number of training events for implementing partners on GEWE; Number of regional and national gender experts trained (disaggregated by sex)

²⁶⁶ Operationalised through indicators: (i) % of staff costs spent on gender-related activities; (ii) Human resources in the gender team.

²⁶⁷ In addition, the 2019 GAP includes output indicators: Senior Management gender champion appointed; Number of systems developed for periodic tracking of the allocation of staff time and activity devoted to gender.

Table 20
IFAD’s commitments and achievements in the ninth, tenth, eleventh and twelfth replenishment cycles

Indicators	IFAD9 (2013-2015)		IFAD10 (2016-2018)		IFAD11 (2019-2021)		IFAD12 (2022-2024)	
	Target	Achieved	Target	Achieved	Target	Achieved	Target	Achieved (only 2022)
Projects rated 4+ at design (percentage)	N/A	N/A	90	92	N/A	100 (2021)	N/A	100
Projects rated 4+ at completion (percentage)	90	89	90	88	90	90	90	89
Projects rated 5+ at completion (percentage)	N/A	N/A	N/A	44	60	53	60	42
Women in P-5 posts or above (percentage)	35	26	35	30.9 (2018)	35	38.1 (2021)	40	44.4
Projects validated as Gender Transformative at design (percentage)	N/A	N/A	15	15	25	35 (RIME 2023)	35	52% (as of August 2023) ²⁶⁸
UN-SWAP indicators met or exceeded	N/A	11/15 (2015)	15/15 by 2017	13/15 (2017)	N/A	14/17 (2021)	N/A	14/17

Sources: Reports of the consultation on Replenishments of IFAD resources as presented to the Governing Council for targets, and relevant RIDEs for outreach, RIME 2023.

²⁶⁸ Source: RIM, 2023. According to discussions with the IFAD team in charge of this validation in OPR, the numerator is the number of projects that are validated as gender transformative divided by the total number of projects that have social inclusion themes validations (eligible for social inclusion screening).

Table 21
Alignment of SDG5 targets with IFAD 2012 Gender Policy

<i>IFAD Gender Policy (2012)</i>	<i>SDG 5 targets</i>
Strategic Objective 1: promote the economic empowerment to enable rural women and men to participate in and benefit from profitable economic activities. However, less emphasis on access to land or other resources.	Economic Empowerment: Target 5.a seeks to ensure equal rights to economic resources, access to and control over land and other forms of property.
Strategic Objective 2 is to enable women and men to have equal voice and influence in rural institutions and organizations.	Participation and Leadership: Target 5.5 aims to ensure women's full and effective participation and equal opportunities for leadership at all levels of decision-making in political, economic, and public life.
Strategic Objective 3 is to achieve a more equitable balance in workloads and in the sharing of economic and social benefits between women and men.	Unpaid Care and Domestic Work: Target 5.4 calling for the recognition and value of unpaid care and domestic work and the promotion of shared responsibilities within the household and the family. Target 5.a. undertake reforms to give women equal rights
Not covered in the strategic objectives of IFAD's gender policy, but importance recognised as part of policy dialogue. Recent criteria for GT-validated projects (from 2019)	Improvement of legal frameworks for gender equality. Target SDG 5c focuses on strengthening policies and enforceable legislation for the promotion of GEWE.

Source: desk review by the TE team

Timeline of IFAD corporate documents with reference to gender during the evaluation period

Figure 14
Key corporate documents during the evaluation period

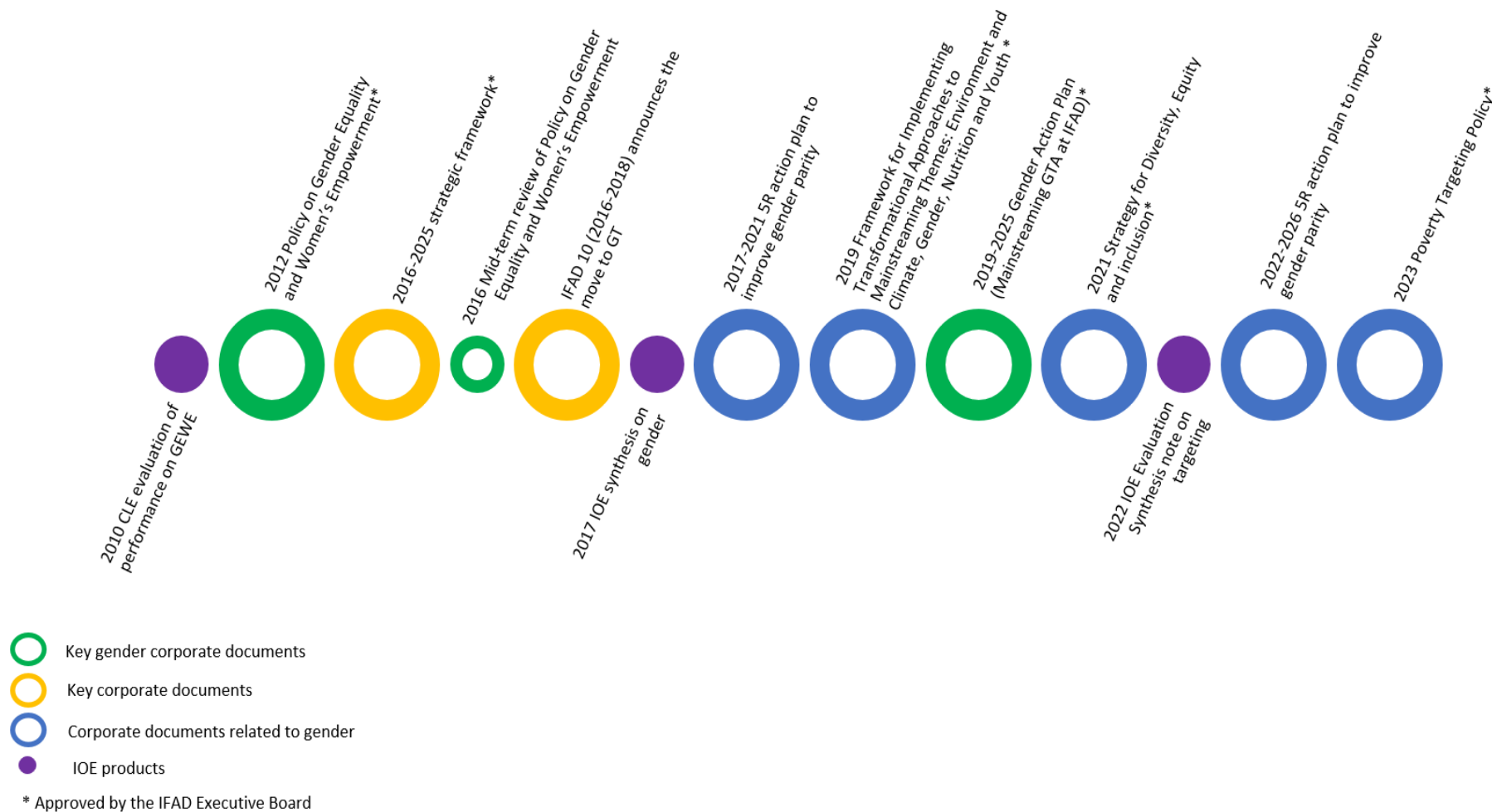

Characteristics of other household methodologies used in IFAD interventions.

Table 22
Key information about other HHM less frequent in IFAD’s portfolio

Name of the HHM	IFAD projects applying HHM	Purpose and main characteristics
GALS+	Madagascar PROGRES, Rwanda PSAC	GALS+ explores additional aspects related to knowledge and attitudes in nutrition and climate-smart practices, specifically climate adaptation mechanisms. Incorporating nutrition within GALS tools aims to combat malnutrition and unhealthy eating habits in rural communities. These challenges often result from lack of knowledge on food’s nutritional value, and women’s limited control on income. Climate change compounds these issues, leading to environmental degradation and reduced agricultural yields. Integrating climate change within GALS aims at empowering beneficiaries to engage in both mitigation and adaptation efforts fostering sustainable agricultural production and resilience.
Household Mentoring	Uganda PRELNOR, NOPP and NOSP; Malawi PRIDE-ERASP; Nepal VITA	HH mentoring was inspired by the Zambian government’s Agriculture Support Programme, and it was further developed by IFAD in Malawi and Uganda, incorporating elements from GALS (such as visioning tools). For instance, GALS tools are used for the household situational analysis (such as the gender balance tree), where often is found that the vulnerabilities of many mentored households were based on gender-related challenges regarding workloads, benefit sharing, asset ownership and decision-making. Mentors help 8-10 households develop a vision and related action plans and help them achieve this vision through sharing knowledge, skills and information in order to foster the personal, social and economic growth of the household members. They also connect households with other development interventions and public services. Mentors from the local community typically visit every two to four weeks during an extended period (up to three years) with reduced frequency as households adopt to the methodology and demonstrate positive changes. Many graduates from these households also become peer trainers, sharing the methodologies with others. Field Supervisors provide technical support and oversight to mentors, ensuring the program’s effectiveness and sustainability. This approach contributes poor rural households develop self-esteem and improve their household gender relations and their livelihoods. It is often used as part of a graduation model for poor households.
Business Action Learning for Innovation (BALI)	Kyrgyzstan AMP; Lao AFN II	The BALI methodology adapts the Participatory Action Learning System (PALS)-based livelihoods and financial strengthening tools for business innovation by women’s groups and associations. They can also be used by individuals and households. BALI tools are used to develop critical and creative thinking to identify ideas for business innovation and develop investment and saving plans. Furthermore, the key theme of individual responsibility and need for contribution is accentuated during the training. Intra-household gender dynamics are addressed since a key tenet of BALI is that economic development can be successful “if the household members are happy”. BALI was piloted in 2019-2020 in Kyrgyzstan within the framework of JP-RWEE with community champions who were already familiar with GALS.
Financial Action Learning System (FALS)	Mali INCLUSIF and Burundi PAIFAR-B Malawi FARMSE	It is an approach towards a responsible finance partnership between marginalized clients and financial service providers (FSPs). It integrates PALS tools with tools for financial empowerment to promote collaboration between FSPs and client for successful product development and delivery. It uses inclusive pictorial methodologies for financial empowerment of women and men from all backgrounds, including the ultra-poor. FALS aims at helping family members develop synergy in decision-making, including decisions on savings and investment. GEWE is deeply integrated into this methodology as improved gender relations significantly influence household savings and ensure that women benefit from financial services. Furthermore, a gender analysis is conducted in the planning phase and gender dimensions are included in monitoring and evaluation frameworks.

Source: Proposal to scale up GALS in the JP RWEE – 2019 (Phase II)

Gender Model Family (GMF)	Ethiopia PACT and PASIDP II	GMF is a gender transformative approach that enables married men and women (couples, partners) to address unequal power relations and decision making about household resources. GMFs use their positive experiences – especially the benefits gained by women, men, boys and girls of the household – to champion and advocate for gender equality in their communities” (JP GTA Compendium, 2020). Through trainings, community meetings and experience sharing, GMF facilitators accompany husbands and wives in their transition from a “traditional family” to a “Gender Model Family”. The implementation cycle is approximately one year, after which the new GMFs act as a catalyst in their communities recruiting other GMFs. Each GMF member is expected to recruit at least three households after practising the approach.
---------------------------	-----------------------------	---

While originally GMF focused on household workload share, PACT will test an updated version that includes additional tools such as visioning and joint decision-making that could cover key food-related issues.

Sources: IFAD, 2014; IFAD, 2019 (a); IFAD, 2019 (b); GAMEChange Network; Mayoux, 2017; FAO, IFAD and WFP, 2020; IFAD Project Design Reports; 2023 Webinar for International Rural Women’s Day.

Compliance criteria for GT-validated project designs

Box 26

Compliance criteria for a project to qualify as gender transformative at design.

- Specific situation analysis: describe national policies, strategies and actors addressing gender; identify the different roles, interests and priorities of women and men and the underlying structures and norms of exclusion and discrimination; identify the most important livelihood problems and opportunities faced by the community, as seen by women and men.
- Integration in theory of change: address all three gender policy objectives in ToC; showcase gender transformative pathways; plan for policy engagement on Gender Equality and Women's Empowerment.
- Mandatory logframe indicators (outreach & outcome): disaggregate Outreach indicator by sex, youth and (if relevant) Indigenous Peoples; at least 40% of project beneficiaries are women for persons receiving services promoted or supported by the project and include the IFAD Empowerment Index (individuals demonstrating an improvement in empowerment) to measure change in women's empowerment.
- Dedicated human & financial resources: include staff with gender-specific TORs; allocate funds to deliver gender-related activities; allocate funds in the M&E budget to undertake the IFAD Empowerment survey at baseline, mid-term review and completion.

Source: IFAD Operations Manual -design, Annex VII, Mainstreaming Guidelines for social inclusion themes, 2023.

Additional information about the review of a sample of GT-validated PDRs:

The methodology used is included in Annex 4- building block 12.

PDRs validated as gender transformative have not consistently received the highest gender ratings from QAG. Out of the 47 projects that OPR validated as GT, only 4 received the highest gender rating (6) at design by QAG, while 24 were rated 5, and 15 rated 4 or 4.5.²⁶⁹ According to exchanges with QAG, the methodology and justification for the ratings were less systematic in the past but between 2020 and 2023 QAG used guiding questions from the IFAD Development Effectiveness Matrix Plus (see section V). In general, the gender rating by QAG reviews the overall logic and integration throughout project design, while the GT validation follows strict compliance criteria.

The situational (gender) analysis in GT PDRs generally complies with the expected criteria, although some lack sufficient detail. Most PDRs include some information about national policies or strategies addressing gender issues in the rural development sector, main livelihoods problems for rural men and women and lessons from previous IFAD projects and evaluations on gender. However, less information is included about key actors involved in gender issues.²⁷⁰ While four GT projects offer a good description of multiple root causes contributing to inequalities, this information is scant in the other four GT-validated projects. Since 2019, project designs rated 5 (gender mainstreaming) and 6 (gender transformative) need to address the three strategic objectives. The proposal about economic empowerment and equal voice is mentioned in all PDRs (in the main text, logframe or theory of change section). However, information about how the project proposes to improve the third objective is less detailed, except for two GT-PDRs (**Cameroon** PADFA II, **Kenya** KELCOP).

The narrative of GT PDRs claims to act on social norms, but the gender transformative pathways are not always clear, including the level of intervention. GT PDRs need to showcase gender transformative pathways. However, the information in the PDR about the gender gaps the project aims to contribute to close and the approaches/strategies to do it are not always clear.²⁷¹ In some cases, the PDR acknowledges the need to change gender norms at the field level, but the PDR does not elaborate further, leaving it to the development of the project gender strategy at a later stage. In others, the PDR only includes a list of activities/GEWE practices which can contribute to overcome barriers (such as the ones analysed in the Section IV.B). For instance, *GALS* or *Cerrando Brecha* are considered as a pathway per se to address gender norms.

Very few PDRs include targets or budget details for measuring empowerment at baseline in IFAD projects. The IFAD Core Outcome Indicators guidelines recommend that, for projects with insufficient baseline data, at least 25% of individuals benefiting from the GT project should show an improvement in empowerment. Some GT PDRs include generic statements in the logframe, while others provide more ambitious and quantifiable expectations of change.²⁷²

²⁶⁹ Three GT-validated projects do not have QAG ratings because they are emergency or additional funding operations.

²⁷⁰ Good practices in relation are: **Sri Lanka** SARP (Ministry of Women and Child Affairs), **China** Y2RDP and H2RDP (Women's organizations), **Argentina** PROSAF (Ministry on Women, Gender and Diversity and the Secretary on Family farming), **Cambodia** ASPIRE-AT (Ministry of Women's Affairs).

²⁷¹ This was also found by the review of 28 GT-validated projects commissioned by IFAD management (June 2022).

²⁷² **Tunisia** PDR proposes to increase the empowerment level of 65% of the supported women, **Cambodia** PDR mentions a change of six percentage points of the A-WEAL, using as baseline a previous study by USAID and **Kenya** included % of targeted women reporting an increase in empowerment (50% at mid-term and 80% as the final target).

Timeline of IFAD’s efforts to improve the measurement of (women’s) empowerment.

Table 23
Timeline of the development of the gender-related assessment methodologies at IFAD

	2012	2013	2015	2017	2018	2020	2023
							WEAI
IFPRI			A-WEAI		PRO-WEAI		
IFAD (RIA)		R-WEAI	A-WEAI		I-WEAI *		women’s empowerment**
Development of IFAD core indicators, including empowerment index (ECG-OPR)				Development of COI Framework and guidelines		Inclusion of the EI (based in proWEAI) in the COI guidelines (March 2020)	

Source: TE Gender

* Used in six of the 24 project impact assessments to inform the IFAD11 impact assessment

**Proposed new impact indicator in IFAD13

WEAI: Women’s Empowerment in Agriculture Index; A-WEAI: Abbreviated WEAI; PRO-WEAI: project WEAI; R-WEAI: reduced WEAI; I-WEAI: integrated WEAI; COI: IFAD’s corporate outcome indicators; ECG: IFAD’s environment, climate, gender and social inclusion division; OPR: IFAD’s operational policy and results division; RIA: IFAD’s Research and Impact Assessment division; IFPRI: International Food Policy Research Institute.

Table 24
Info to measure Women’s Empowerment in Agriculture Index (5DE components)

Domain	Indicator	Weight
Production	Input in productive decisions	1/10
	Autonomy in production	1/10
Resources	Ownership of assets	1/15
	Purchase, sale or transfer of assets	1/15
	Access to and decision about credit	1/15
Income	Control over use of income	1/5
Leadership	Group member	1/10
	Speaking in public	1/10
Time	Workload	1/10
	Leisure	1/10

Source: Alkire, S., Meinzen-Dick, R., Peterman, A., Quisumbing, A., Seymour, G., & Vaz, A. (2012). The women’s empowerment in agriculture index. IFPRI Discussion Paper.

Various versions of WEAI:

Figure 15
Comparison of domains and indicators of WEAI, A-WEAI and pro-WEAI

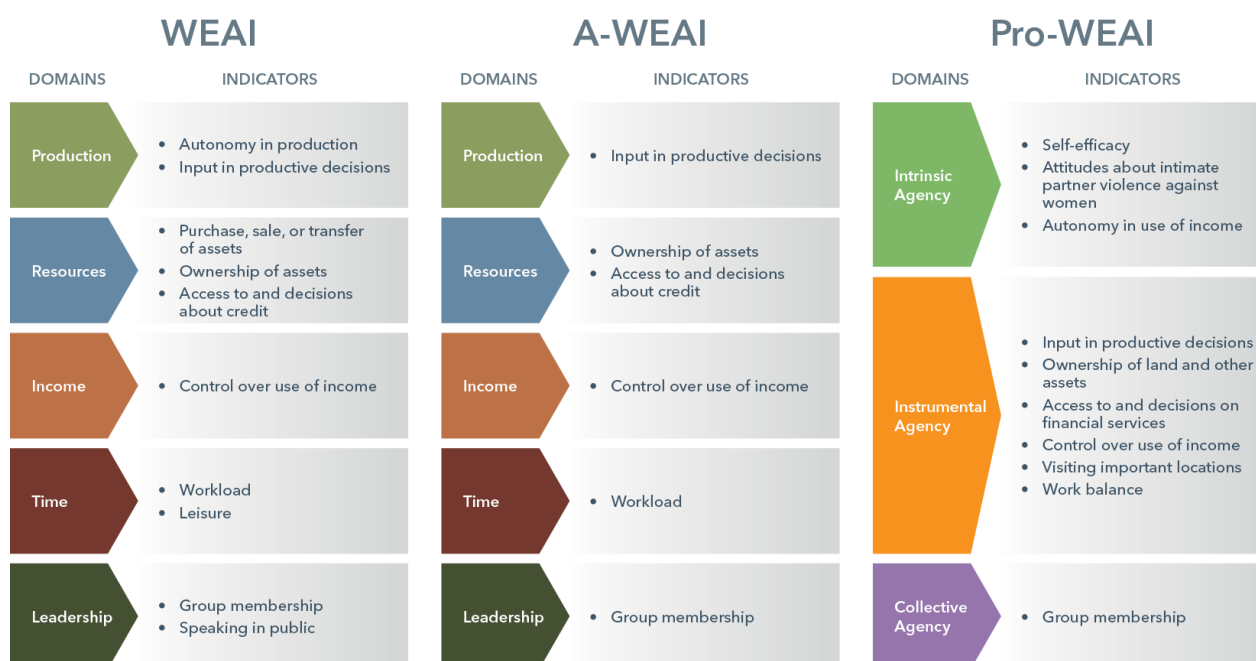

Source : <https://weai.ifpri.info/versions/>

Table 25
Questions for computing the reduced WEAI (R-WEAI).

Dimension	Indicator name	Survey question
Production	Input in productive decisions	How much input did you have in making decisions about food crop farming, cash crop farming, livestock-raising and fish culture?
	Autonomy in production	To what extent do you feel you can make your own personal decisions regarding these aspects of household life if you want to? Aspects: types of inputs to buy and types of crops to grow for agricultural production. My actions are partly because I will get in trouble with someone if I act differently. I do what I do so others don't think poorly of me; I do what I do because I personally think it is the right thing to do. Domain: inputs to buy and crops to grow.
Resources	Ownership of assets	Who would you say can use the assets most of the time? Assets: agricultural land, small livestock, large livestock, non-mechanized agricultural tools, mechanized farm equipment, non-farm tools, small and large durable goods, cell phone, transport.
	Purchase, sale or transfer of assets	Who would you say can decide whether to sell, give away, rent/mortgage assets most of the time? Who contributes most to decisions regarding a new purchase of assets? Assets: agricultural land, small livestock, large livestock, non-mechanized agricultural tools, mechanized farm equipment.
	Access to and decisions about credit	Who made the decision to borrow/what to do with money/item borrowed from [source]? Sources: formal lender (bank), friends or relatives, microfinance groups, cooperative savings.
Income	Control over use of income	How much input did you have in decisions about the use of income generated from food crop, cash crop, livestock, non-farm/wage activities and fish culture?

		To what extent do you feel you can make your own personal decisions regarding these aspects of household life if you want to? Aspects: minor household expenditures.
Leadership	Group membership	Are you a member of any groups? Groups: agricultural/livestock/fisheries producer/market group; water, forest users' credit or microfinance group; mutual help or insurance group (including burial societies); trade and business association; civic/charitable group; local government; religious group; other group.
	Speaking in public	Do you feel comfortable speaking up? Topic: productive infrastructure.
Time	Leisure time	How would you rate your satisfaction with your time available for leisure activities such as visiting neighbors, watching TV, listening to the radio, seeing movies, or practicing sports?
Demographic characteristics	Individual age	What is an individual's age?
	Age gap between men and women	What is individual's spouse's age?
	Primary school	What is the highest grade of education completed by the individual? Education: never attended school, attended class I, completed class I, completed class II, completed secondary school.
Wealth	Household asset index (factor analysis)	Does anyone in the household currently have any of these items? Who would you say owns most of the items? Items: large and small livestock, poultry, agricultural or fish equipment, non-mechanized and mechanized farm equipment, business equipment, large and small consumer durables, cell phone and means of transport.

Source: Garbero, A., & Perge, E. (2017).

Table 26
Version of WEAI used in the IFAD 11 project impact assessments and indicators covered.

Country & Project	WEAI Type	Indicators adapted from their original form in pro-WEAI
Ghana (REP III) Rural Enterprises Programme Phase III	i-WEAI	Input in productive decisions; Ownership of land and other assets; Access to and decisions on credit; Control over use of income; Group membership; Membership in influential groups*
Kenya (UTaNRMP) Upper Tana Catchment Natural Resources Management Project	i-WEAI	same
Mali (PMR) Rural Microfinance Programme	i-WEAI	same
Mauritania (PASK II)	i-WEAI	Autonomy in income; Self-efficacy; Attitudes about intimate partner violence; Respect among household member; Input in production decisions; Ownership of land and other assets; Access to and decisions on financial services; Control over use of income; Work balance; Visiting important locations; Group membership; => without indicated any details
Nigeria (VCDP) Value Chain Development Program	i-WEAI	Input in productive decisions; Ownership of land and other assets; Access to and decisions on credit;

		Control over use of income; Group membership; Membership in influential groups*
Pakistan (SPPAP)	<i>Pro-WEAI</i>	Not indicated in the report
Papua New Guinea (PPAP)	i-WEAI	Not specified; Self-efficacy; Attitudes about intimate partner violence; Respect among household members; Input in production decisions; Ownership of land and other assets; Access to and decisions on financial services; Work balance listed.
Tanzania (MIVARF) Value Addition and Rural Finance Support Project	i-WEAI	Input in productive decisions; Ownership of land and other assets; Access to and decisions on credit; Control over use of income; Group membership; Membership in influential groups*

Source: [IFAD Impact assessment 2019-2021 micro webpage](#)

Figure 16
Mandatory reporting requirements for all IFAD-financed projects, and specifics for GT ones

Table II. Mandatory reporting requirements for all IFAD-financed projects

Type of Project	CI OUTREACH	CI OUTPUTS	CI OUTCOMES
All projects	<ul style="list-style-type: none"> ▪ C.I.1: Persons receiving services promoted or supported by the project Mandatory multipliers: <ul style="list-style-type: none"> - Total number of persons receiving services⁹ - Males - Females - Young¹⁰ - Indigenous people (if relevant) - Persons with disabilities (if relevant) ▪ C.I.1.a: Corresponding number of households reached C.I.1.b: Estimated corresponding total number of households members 	<ul style="list-style-type: none"> ▪ For all people-based CI outputs: Mandatory multipliers: <ul style="list-style-type: none"> - Total number of persons receiving services¹¹ - Males - Females - Young¹² - Indigenous people (if relevant) - Persons with disabilities (if relevant) 	<ul style="list-style-type: none"> ▪ For all households-based CI outcomes: Mandatory multipliers: <ul style="list-style-type: none"> - Number of households - % of households - HH members Stakeholders Feedback¹³: <ul style="list-style-type: none"> ▪ SF.2.1: Households satisfied with project-supported services <li style="text-align: center;">AND ▪ SF.2.2: Households reporting they can influence decision-making of local authorities and project-supported service providers
Gender transformative projects <i>At least 35% of projects approved in IFAD12</i>	<p style="text-align: center;">Same as All projects</p> <p style="text-align: center;">AND</p> <p>Target: At least 40% of project beneficiaries are women – for:</p> <ul style="list-style-type: none"> ▪ C.I.1: Persons receiving services promoted or supported by the project 	Same as All projects	<p style="text-align: center;">Same as All projects</p> <p style="text-align: center;">AND</p> <ul style="list-style-type: none"> ▪ IE.2.1: Individuals demonstrating an improvement in empowerment (IFAD empowerment index): Mandatory multipliers: <ul style="list-style-type: none"> - Total persons (number) - Total persons (%) - Females (number) - Females (%) - Males (number) - Males (%)

Source: from 2022 May IFAD COI core indicators framework-update_12.05.22" file, page 7.

Figure 17
Estimation of IFAD’s Empowerment Indicator

**ESTIMATION IFAD’S EMPOWERMENT INDICATOR,
CI IE.2.1: Individuals demonstrating an improvement in empowerment**

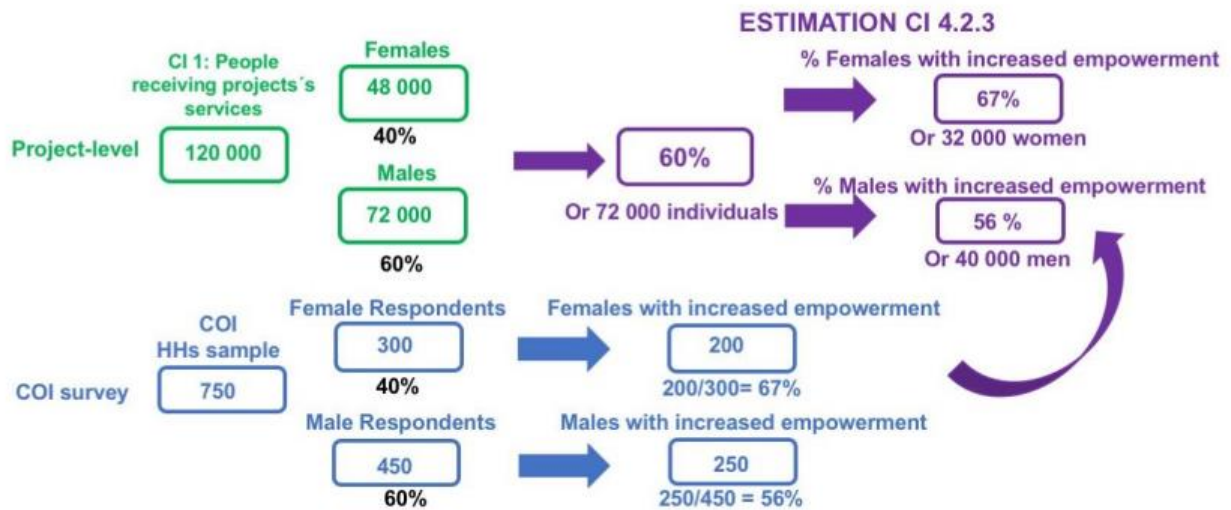

Source: IFAD OPR 2021. Core Outcome Indicators Measurement Guidelines (COI) Appendices. Rome, Italy. October 2021.

Roles and responsibilities of human resources working on GEWE

Table 27
Roles and responsibilities of gender architecture components

<i>Gender architecture</i>	<i>Roles and responsibilities</i>	<i>Information sources</i>
1. Gender and social inclusion team with global responsibility	Covers three different work streams: GEWE, poverty targeting, and persons with disabilities. The former two are mainstreamed throughout all IFAD-supported country programmes. Responsible for five areas of work: <ul style="list-style-type: none"> • Support to country programmes and projects (gender policy action area 1); • Advocacy, partnerships and knowledge management (gender policy action area 2); • Capacity building of staff and implementing partners (gender policy action area 1 and 3); <ul style="list-style-type: none"> • Resource mobilisation, M&E and accountability (gender policy action area 5); • Grants and supplementary funded programmes (gender policy action area 1 and 2). 	Gender and social inclusion team self-assessment presentation, presented during TE Gender workshop, March 2023 Analysed against 2012 Gender Policy
2. Staff with regional responsibility for (gender and) social inclusion	<ul style="list-style-type: none"> • Provision of technical and country programme advice through participation in PDTs (project design, start-up, implementation support, supervision, mid-term review, completion missions) • Provision of support in-between missions to country teams and PMUs e.g. on knowledge management, capacity building and technical support. <ul style="list-style-type: none"> • Partnership building and resource mobilisation <ul style="list-style-type: none"> • Monitoring, evaluation and reporting 	Job profile on IFAD intranet Interviews
3. Divisional gender focal points.	<ul style="list-style-type: none"> • Being a reference point on gender, targeting and social inclusion related issues in the division; <ul style="list-style-type: none"> • Providing colleagues with access to relevant tools, materials and resources; • Supporting the implementation of the gender action plan at the divisional level: ○ Identifying gaps and needs, work with the gender team to develop initiatives and provide support; <ul style="list-style-type: none"> ○ Defining yearly commitments and activities to be implemented at divisional level; ○ Contributing to awareness raising and capacity development on gender if and as required. • Contributing divisional up-dates and gender and targeting knowledge products for web posting; <ul style="list-style-type: none"> • Participating actively in IFAD's Gender Team and Thematic Group on Gender (TG-Gender); • Encouraging the division to draw on the expertise of the ECG Gender Team for quality enhancement of initiatives to promote social inclusion, gender equality and empower women, including grants, knowledge products etc.; • Contributing to the identification (and inclusion of the IFAD Gender Network) of key resource people working on gender in their respective domain; • Ensuring gender, social inclusion and diversity considerations are mainstreamed into all aspects of human resource management within the division and IFAD as organization (for HRD focal points). 	Divisional GFP terms of reference
In addition, there are also gender focal points in a minority of regional / multi-country offices.		
4. Senior management gender champion	To be the leading voice within and outside of IFAD on the promotion of gender equality in rural and agricultural development.	IFAD UNSWAP reports (various)
5. Gender and social inclusion consultants	Tasks vary by assignment but contribute to the five main areas of work under the remit of the gender and social inclusion team. The bulk of consultants are hired to contribute to the delivery of country programmes and projects by participating in missions and writing reports throughout the COSOP/project cycle.	TE Gender interviews and document reviews
6. The gender community - thematic group (IFAD staff & consultants) - gender network	Thematic group – Technical support to the gender and social inclusion team and oversight committee; knowledge sharing Gender Network – emailing lists for staff, consultants, project staff and external partners - to keep stakeholders up-to-date on events, news and project level lessons learned.	2012 Policy on GEWE TE Gender interviews and document reviews

Additional info on comparison with other organizations

Gender analysis is the cornerstone of any gender policy and for some agencies it is mandatory. A gender analysis is mandatory in Sida and the World Bank investments. A Rapid Gender Analysis has become the trademark of CARE with its [RGA Toolkit](#) and [Library](#). IFAD's gender policy stresses that better-functioning projects generally had, among other factors, a well-articulated gender strategy grounded in gender and socio-economic analysis. This was confirmed by the TE. IFAD supports and promotes gender analysis during the design of its investment projects and country strategies. However, there are no mechanisms in place at IFAD to reject a project because it had not done a gender analysis at design or because its quality is not considered enough.

All 8 organizations use a gender marker to measure the integration of gender in their programmes and/or strategies. With various scales and definitions, each organization rates their interventions according to perceived contribution to GEWE. Only CARE and IFAD include gender transformative at the top end of the scale²⁷³. According to interviews with key gender staff at IFAD, GTAs are considered a step beyond mainstreaming gender in projects and programmes and are more likely to focus on the root causes of discrimination and inequalities. In relation to GT programming, gender mainstreaming is considered as the foundation for, and is an integral part of, GT designs (rather than merely a subset).

Some organizations had already incorporated GTA into their corporate documents before IFAD started to do so in 2016. By 2023, all comparator organizations recognise the need to address the root causes of inequalities and introduce some form of GTAs to improve the livelihoods of the rural poor. SIDA was one of the first to mention GTAs in its policy documents in 2008, followed by CARE and OXFAM in 2010 and 2011 respectively. The other organizations began to reference GTAs in corporate documents between 2012 and 2020. IFAD began to mention GTA in corporate documents from 2016 onwards. The Interagency Standing Committee (IASC) as a hub for humanitarian organizations also recently included transformative concepts.²⁷⁴ Since 2007, IFAD has pioneered the implementation of GTA methodologies in its rural development portfolio, mainly through GALS.²⁷⁵ FAO also started promoting GTAs with the Dimitra clubs in 2007.²⁷⁶

In terms of partners for gender related work, all the organizations reviewed collaborate with a range of actors. Typical collaborators include women's organizations, civil society, governments, multilateral partners, academia, and private sector. Women's organizations on the ground are mentioned or listed by most as important partners, although to different extents. Most organizations stress the need for men's engagement to address gender equality concerns. Some of the comparators, such as the AfDB, have developed specific initiatives to leverage financial instruments to create incentives for private banks and microfinance institutions to invest in women-led

²⁷³ For instance, CARE uses a 4-point scale from gender unaware to gender transformative, UNDP a 3-point scale from no contribution to GEWE to GE as the principal objective, and WFP, using the IASC [gender with age marker](#), uses a 0 to 2 code to reflect how consistently the project has selected the intended genders, ages and people with disabilities. The World Bank and AfDB also use gender markers.

²⁷⁴ The Operational Policy and Advocacy Group of the Interagency Standing Committee is at the time of writing this report pending endorsement of the updated gender policy, which calls for the humanitarian, development and peace nexus to be transformative, inclusive and uncompromising towards achieving the goals of gender equality and the empowerment of women and girls in the planning, implementation, monitoring and evaluation of coordinated humanitarian response.

²⁷⁵ GTAs had already been promoted by some donors and service agencies that work with IFAD (e.g., CARE, the Swedish International Development Cooperation Agency -SIDA, Oxfam, Hivos and PROCASUR).

²⁷⁶ Dimitra clubs are set up for groups of women, men and young people – mixed or not – who organize on a voluntary basis to bring about changes in their communities and resolve problems using their own resources, without relying on external support. <https://www.fao.org/in-action/dimitra-clubs/fr/>

businesses.²⁷⁷ The UNDP private sector strategy mentions developing Gender Equality Bonds to mobilize additional private finance.²⁷⁸

Each entity has its own mechanism for GEWE knowledge generation and dissemination. Examples include through toolkits, newsletters, evidence evaluations, guidance notes, gender briefs, *How to Do* notes, blogs, gender equality profiles. Some organizations (FAO, World Bank, IFAD) invest in webinars to share lessons on GEWE, often with partners working in collaboration on the ground, or research organizations contributing to gender concept elaboration or GTA testing. Many documents across all comparator agencies focus on lessons learned, with less documentation on challenges and failures.

²⁷⁷ [Affirmative Finance Action for Women in Africa](#), AFAWA.

²⁷⁸ <https://www.undp.org/sites/g/files/zskgke326/files/2023-10/undp-private-sector-development-and-partnerships-strategy-2023-2025.pdf>

GEWE performance ratings and trends in IFAD interventions

Figure 18
Share of projects rated above and below 5 for GEWE using PCR and IOE ratings, by IFAD regional division.

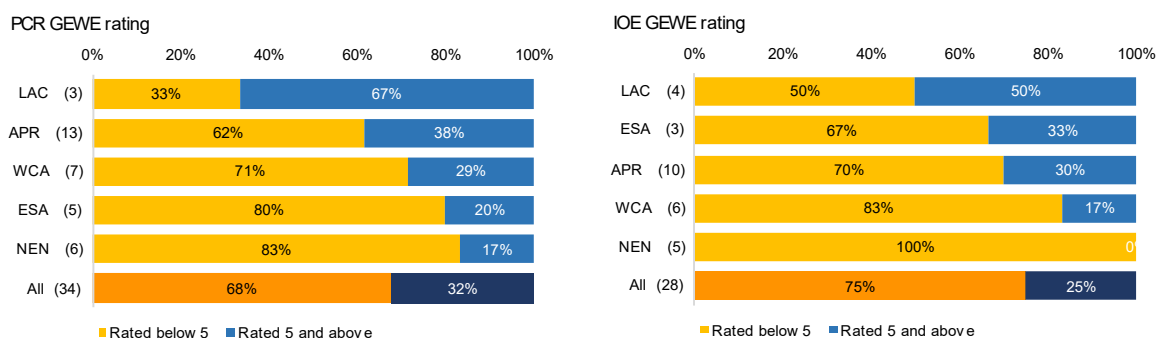

Source: Thematic evaluation team, based on IFAD ORMS completion rating and IOE rating database (accessed in February 2023).

Note: APR – Asia and the Pacific; ESA – East and Southern Africa; LAC – Latin America and the Caribbean; NEN – Near East, North Africa, Europe and Central Asia; WCA – West and Central Africa.

Figure 19
Distribution of PCR and IOE GEWE ratings for projects approved in 2013-2022

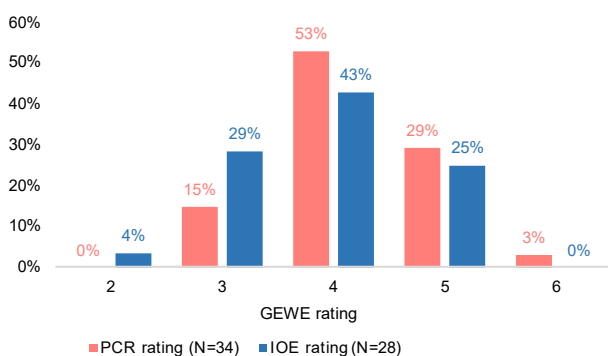

Source: Thematic evaluation team, based on IFAD ORMS completion rating and IOE rating database (accessed in February 2023).

Figure 20
Trend of GEWE performance using IOE ratings

Share of projects rated moderately satisfactory (4) or better, projects completed in 2013-2022 (N=267).

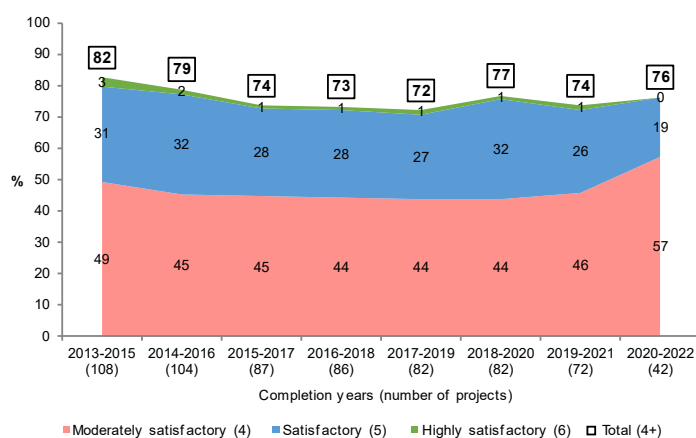

Source: Thematic evaluation team, based on the IOE rating database (accessed in February 2023)²⁷⁹.

²⁷⁹ The figure is consistent with ARIE 2023, The number of projects is identical, except from 2018-2020 onwards because the TE already included the Laos PPE.

Table 28
Quantitative information on GEWE extracted from ARRIs

Indicators	ARRI 2013	ARRI 2014	ARRI 2015	ARRI 2016	ARRI 2017	ARRI 2018	ARRI 2019	ARRI 2020	ARRI 2021	ARIE 2022
Project completion year:	2009-2011	2010-2012	2011-2013	2012-2014	2013-2015	2014-2016	2015-2017	2016-2018	2017-2019	2018-2020
[no. of projects]	[43]	[44]	[55]	[56]	[65]	[57]	[59]	[63]	[66]	[71]
Proportion of projects (PCR/V/PPA/PPE/IE) rated moderately satisfactory or better 4+ in GEWE (%)	74	75	89	91	85	77	71	71	76	76
Proportion of projects (PCR/V/PPA/PPE/IE) rated satisfactory or better 5+ in GEWE (%)	N/A	N/A	51	53	38	39	38	29	26	35
Internal benchmarking: GEWE performance against corresponding RMF target (in terms of % of projects rated moderately satisfactory or better, 4+) ^a	-6 (74% of IOE rating – 80% of 2010-2012 RMF)	-5 (75% of IOE rating – 80% of 2010-2012 RMF)	-1 (89% of IOE rating – 90% of 2013-2015 RMF)	1 (91% of IOE rating – 90% of 2013-2015 RMF)	-5 (85% of IOE rating – 90% of 2013-2015 RMF)	-13 (77% of IOE rating – 90% of 2016-2018 RMF)	-19 (71% of IOE rating – 90% of 2016-2018 RMF)	-19 (71% of IOE rating – 90% of 2016-2018 RMF)	-14 (76% of IOE rating – 90% of 2019-2021 RMF)	-14 (76% of IOE rating – 90% of 2019-2021 RMF)
Ranking of GEWE criteria among all IOE evaluation criteria, in terms of projects rated as satisfactory or better, 5+ (PCR/V/PPA/PPE/IE). ^b	N/A	6/16 criteria	3/16 criteria	4/14 criteria	N/A	9/14 criteria	9/14 criteria	9/13 criteria	9/13 criteria	6/13 criteria
Average of GEWE rating in IOE evaluated projects (PCR/V/PPA/PPE/IE)	N/A	N/A	4.4	4.4	4.2	N/A	N/A	4.0	3.5	4.1
Proportion of projects (PCR/V/PPA/PPE/IE) rated: ^c										
Highly satisfactory (6)	N/A	N/A	6	4	5	2	2	2	0	0
Satisfactory (5)	N/A	N/A	46	49	34	37	36	27	26	35
Moderately satisfactory (4)	N/A	N/A	38	38	46	39	34	43	50	41
Moderately unsatisfactory (3)	N/A	N/A	7	6	N/A	N/A	N/A	N/A	N/A	N/A
Unsatisfactory (2)	N/A	N/A	4	4	N/A	N/A	N/A	N/A	N/A	N/A
Highly unsatisfactory (1)	N/A	N/A	0	0	N/A	N/A	N/A	N/A	N/A	N/A

Indicators	ARRI 2013	ARRI 2014	ARRI 2015	ARRI 2016	ARRI 2017	ARRI 2018	ARRI 2019	ARRI 2020	ARRI 2021	ARIE 2022
Proportion of projects (PCR/PPA/PPE/IE) rated moderately satisfactory or better (4+) by region:										
APR	N/A	N/A	N/A	N/A	N/A	N/A	86	83	82	N/A
ESA	N/A	N/A	N/A	N/A	N/A	N/A	73	60	60	N/A
LAC	N/A	N/A	N/A	N/A	N/A	N/A	70	71	86	N/A
NEN	N/A	N/A	N/A	N/A	N/A	N/A	36	50	78	N/A
WCA	N/A	N/A	N/A	N/A	N/A	N/A	85	73	76	N/A
Project completion year:			2007-2013	2007-2015	2007-2015 ^c	2007-2016	2007-2017	2007-2018	2007-2019	2011-2020
Average of IOE GEWE rating (PCR/PPA/PPE/IE)	N/A	N/A	4.28	4.49	4.22	4.18	4.25	4.22	4.14	4.12
Average of PMD GEWE rating (PCR)	N/A	N/A	4.46	4.51	4.46	4.45	4.57	4.56	4.57	4.48
Disconnect of Average IOE and PMD rating	N/A	N/A	-0.18	-0.02	-0.24	-0.27	-0.32	-0.34	-0.43	-0.36

N/A: data is not available in the respective ARRI report.

^a ARRI 2013, 2014 assessed against the 2010-2012 RMF target (80%); ARRI 2015, 2016, 2017 assessed against the IFAD9 RMF 2013-2015 target (90%); ARRI 2018, 2019, 2020 assessed against the IFAD10 RMF 2016-2018 target (90%); ARRI 2021, ARIE 2022 assessed against IFAD11 RMF 2019-2021 target (90%).

^b This ranking is comparing GEWE criterion position relative to other IOE criteria in terms of the highest share of projects rated satisfactory or better. Since ARRI 2018, ranking across criteria is based on projects rated as moderately satisfactory or better, 4+ (PCR/PPA/PPE/IE).

^c The proportions may not add up to 100% due to rounding of decimals. There are IOE evaluations with ratings 3 and lower from 2017 onwards, but ARRI report did not produce the info anymore.

^d Although the period covered is similar with the previous ARRI, the analysis draws from a larger sample than the 2016 ARRI (151 vs 126 projects).

Source: IOE ARRI 2013-2021, ARIE 2022.

Analysis of GEWE M&E weakness and contributing factors

- **Evidence about the scarcity of evidence in IFAD supervision and completion reports demonstrating how projects/programmes contribute to gender equality and the empowerment of both women and men:**
 - o The absence of robust data on women’s empowerment outcomes was highlighted in both ARRI 2015 and ARRI 2018.
 - o In the reviewed IFAD’s SVP/PCRs, assertions of enhanced women’s decision-making power in households and communities are often presented without comprehensive outcome data.²⁸⁰
 - o Some supervision reports called for surveys to assess the effects and impacts of projects on GEWE (**Tunisia, El Salvador and Argentina**). Isolated examples of such surveys were found.²⁸¹
 - o Among the IOE evaluations synthesized for the TE, 16 out of 22 reported that the endline survey included some gender data. Notably, four projects from these evaluations were selected for impact assessment conducted by RIA.
- **Examples of lack of sex disaggregation of targeted population by sex:** out of the 29 completed projects analysed, 12 of them mentioned youth, 11 ethnic minorities or Indigenous Peoples, and few mentioned internally displaced people, landless, persons with disabilities. Most did not sex-disaggregate data. In addition, supervision reports of the projects in the TE case studies flagged this issue (**Cambodia, Cameroon, Argentina, Ethiopia and El Salvador**).

Factors contributing to the weak gender outcome reporting in IFAD self-evaluations:

The inclusion of an IFAD gender experts in field missions is not consistent across the project cycle. Out of 26 project completion reports examined and with this information, twelve did not include a gender expert, or the team member responsible for gender-related aspects did not possess the necessary expertise. Financial resources to hire gender experts to go on supervision missions are insufficient according to 55% of PMD respondents to the TE e-survey, and 34% and 35% indicated that financial resources are insufficient for design and mid-term review missions. This could partly explain the haphazard gender ratings during implementation, as well as different people going to different missions with different interpretations of the guidance. Capacity building on GEWE to understand IFAD requirements was identified as an issue by 46% of PMD and 49% of PMU e-survey respondents²⁸².

Not all TE e-survey respondents agree on the adequacy of quotas, with some suggesting the feasibility of measuring women’s and men’s access to goods and services offered by the project. Some TE survey respondents disagree that quotas are enough (see box below), and two thirds (66% for PMU and 63% for PMD) indicated it is feasible to measure access (or the actual “benefits” derived or the improvement in their well-being).²⁸³ However, the review of IFAD project reports in the country case studies indicates that access to goods and services is not consistently reported and is

²⁸⁰ For instance, PROGRESS PCR in **Mauritania** claims behavioural changes among women at household and community levels because of project information campaigns, education, without survey evidence. The TE **India** case study flagged the lack of data related to the drudgery reduction interventions claimed in self-evaluation documents.

²⁸¹ Ongoing impact study on the use of Gender Model Family in **Ethiopia** PASIDP II, the use of the empowerment index in the final outcome survey of **Cameroon** PEA-J in 2022 (which found young women who participated in the project had a higher empowerment level than the control group, but lower than the young men who participated in the project).

²⁸² 180 IFAD consultants and staff and 559 PMU staff responded to this question. Statistically significant differences were found for PMU respondents: while in NEN 62% responded as not having received adequate information and training on GEWE, this percentage was 36% in LAC.

²⁸³ The “reach–benefit–empower” framework (Johnson et al., 2018) was devised to help planners distinguish between levels of empowerment strategies and their measurement. Kleiber et al. (2019) added “transform” to the framework to address interventions aiming to transform discriminatory social institutions and unequal power relations.

seldom linked to previously identified gender gaps among rural men and women targeted during the design phase.

Box 27

Views on what is sufficient for assessing GEWE performance in IFAD-supported projects

Most (68%) of PMU e-survey respondents consider male/female quotas for participation in project activities are sufficient in assessing GEWE performance, although less than half (45%) of PMD respondents agree that this is sufficient.

“M/F participation quotas give a quantitative indication but do not reflect the quality of women's activities compared to men's” (Male PMD staff/consultant, WCA, More than 10 years of experience at IFAD)

“It is much easy to access women participation in terms of quantitative data, however, we still face the challenge of qualitative information on women empowerment.” (Female PMU staff, ESA, 2 to 4 years of experience at IFAD)

Source: Responses to the TE e-survey (166 PMD staff and consultants; 522 PMU staff).

Some IFAD and PMU staff perceive it is not necessary to monitor and report on advance towards GEWE results during implementation. Discussions during country studies (**India** and **Argentina**), revealed that there is a perception among some IFAD and PMU staff that suggests that the evaluation of gender effects within IFAD projects is meant to be done by external contractors responsible for conducting outcome/endline survey (or the impact assessment). Such a perception can undermine efforts to improve the quality of gender data measured and reported during project implementation and a failure to include suggestions towards corrective actions that would lead to GEWE outcomes. In addition, the Terms of References of M&E experts in implementation support or supervision missions are mainly focused on key logframe indicators, which rarely include GEWE results related to the three strategic objectives of the IFAD gender policy. According to some interviewees, monitoring and reporting project gender performance is not perceived as part of these broader project M&E efforts (beyond disaggregating data by sex).

Additional information about the GEWE practices in IFAD investments contributing to gender

Table 29
Comparison of the 2017 ES and the 2022 ES findings GEWE on practice areas

Practice areas	2017 ES findings (50 evaluation reports)		2022 ES findings (23 evaluation reports)	
	No. of practices	%	No. of practices	%
1. Access to resources and opportunities ↑	49	39 %	42	46,7 %
1.a Inclusive financial services ↓	22	18,2 %	8	8,9 %
1.b Engagement in IGAs ↑	6	5,0 %	7	7,8 %
1.c Backyards and home gardens	4	3,3 %	3	3,3 %
1.d Technical and vocational training ↑	7	5,8 %	13	14,4 %
1.e Participation in markets and value chains ↑	7	5,8 %	9	10 %
1.f Off-farm employment opportunities ↑	3	2,5 %	2	3,3 %
2. Reducing women's time poverty	14	12 %	10	11,1 %
2.a Infrastructure	10	8,3 %	5	5,6 %
2.b Labor-saving technologies and practices ↑	3	2,5 %	4	4,4 %
2.c Childcare support ↑	1	0,8 %	1	2,0 %
3. Addressing political, legal and institutional constraints ↑	28	24 %	24	26,7 %
3.a Policy engagement at national and local levels	8	6,6 %	6	6,7 %
3.b Representation and voice in local governance institutions ↑	16	13,2 %	15	16,7 %
3.c Legal rights on land and forests	4	3,3 %	3	3,3 %
4. Strengthening women's and men's awareness, consciousness, and confidence ↓	30	25 %	14	15,6 %
4.a Breaking gender roles and stereotypes ↓	12	9,9 %	6	6,7 %
4.b Working with men ↓	6	5 %	4	4,4 %
4.c Functional skills training (literacy, etc.) ↓	12	9,9 %	4	4,4 %
TOTAL	121	100 %	90	100 %

Source: IOE Gender Team elaboration (2022).

Figure 21
% of GEWE practices in the 29 completed projects approved after the gender policy (according to Project Completion Reports and IOE evaluations)

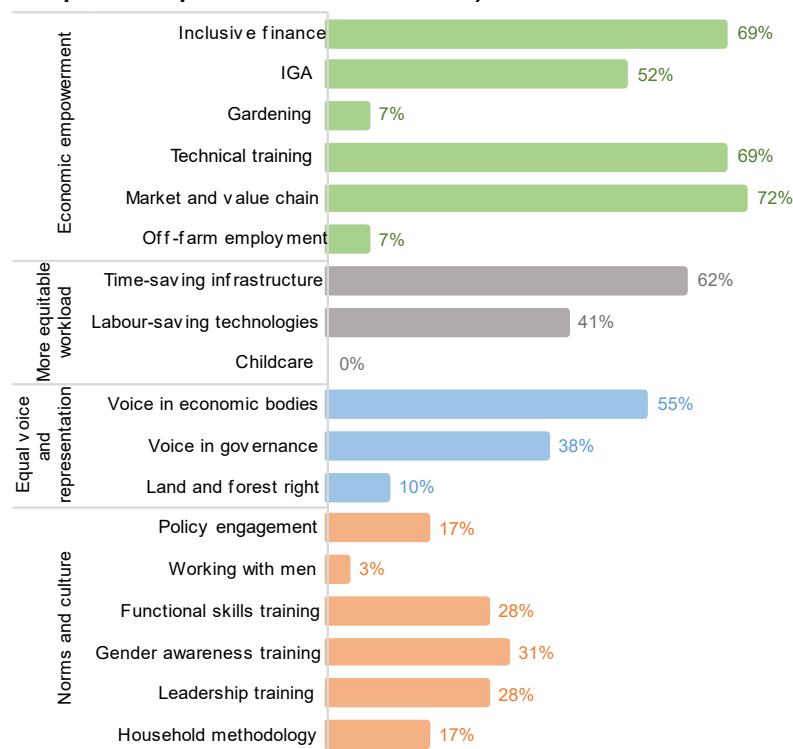

Source: Thematic evaluation team, based on desk reviews (2023).
Note: The percentages do not necessarily have to add up to 100% because a project can have more than one practice.

Figure 22
% of GEWE practices in the 46 projects in the eleven country case studies

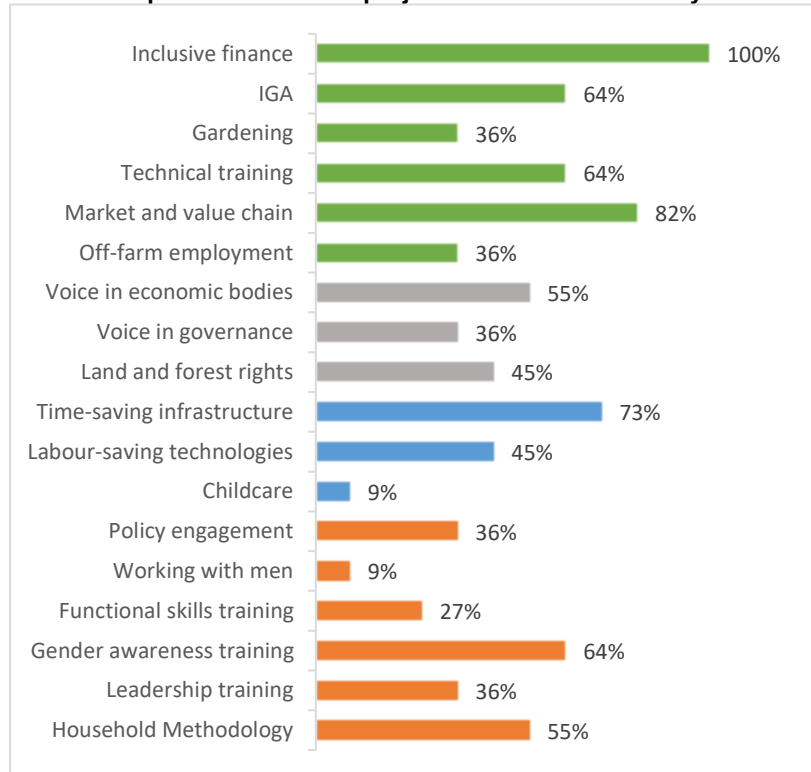

Source: Thematic evaluation team, based on desk reviews (2023).
Note: The percentages do not necessarily have to add up to 100% because a project can have more than one practice.

Table 30
GEWE practices contributing to GEWE in IFAD investments in the eleven-country case studies

<i>2012 Gender objectives</i>	<i>Practice contributing to GEWE results</i>
Economic empowerment (first objective of IFAD gender policy)	Facilitated access to financial services (all) Support for entrepreneurship and income generating activities/IGAs (Cameroon, Tunisia, Kenya, Argentina, Sudan, Türkiye and Mauritania) Support for backyard and home gardening (Kenya, Argentina, Mauritania, Sudan) Training on agronomy, management, nutrition etc. (Cambodia, Cameroon, Sudan, Kenya, India, Mauritania, Ethiopia), telecentres for access to employment services in rural areas (Tunisia) Transition from subsistence to commercial farming (Cambodia, Sudan, Kenya, El Salvador, India, Mauritania, Cameroon), reported improved market access (Cambodia, Argentina, Türkiye). Off-farm activities: Cambodia (weaving), Argentina, Cameroon, Mauritania (handicrafts)
Equal voice and representation (second objective of IFAD gender policy)	Promotion of women participating in management committees of farmers groups (Cameroon, Tunisia, Sudan, Mauritania, Cambodia, Türkiye, India), or self-help groups (India) Young women trained by IFAD projects taking local authorities' position (Cambodia, India), support to women to engage in local development planning (Mauritania), participation of women in village development committees and women interest groups (Sudan).
More equitable workload (third objective of IFAD gender policy)	Time-saving technologies: Water infrastructure (Ethiopia, Tunisia, Argentina, Sudan, India and Mauritania) and other equipment and inputs (Ethiopia, Cambodia, Argentina, Sudan, Türkiye) Labour-saving machinery to do farm work traditionally assigned to women (Cambodia, Cameroon, Tunisia, Türkiye, India) Childcare support for training participants (Cameroon), proposed in Argentina and El Salvador.

Source: Desk review, interviews and field visits

SO1: IFAD interventions and the promotion of economic empowerment

Rural finance:

Good practices/results:

- the establishment or village/oasis savings and credit cooperatives was linked to good results in **Mauritania**, similar to credit associations or village-savings committees in **Sudan**.²⁸⁴
- Supporting business plans for men and women identified (**Argentina, El Salvador, Cambodia, Cameroon, Tunisia**). Also reported in IOE evaluations: **Indonesia CSPE, Rwanda PASP PCRV, Uganda CSPE, Nepal KUBK/ISFP PCRV; Guinea PNAFA-LGF, Vietnam CPRP, AMD and SRDP;**
- **women-only** investment lines revolving funds and (El Salvador, Argentina);

²⁸⁴ The *Absumi* microfinance initiative in **Sudan** works solely with women due to the high repayment rates of women's savings groups. Financial empowerment is mentioned as the entry point to address gender inequalities (when women have economic independence, they can take other decisions without reliance on husbands, parents or relatives).

- use of **microfinance** institutions (Ethiopia, Cameroon, Sudan);
- **micro-grants** for producers and **grants** for milk cooperatives (Türkiye).

Limited results: Although a high percentage of women are reported in **Ethiopia**, **Cameroon**, and **Sudan**, further information about the distinctive products offered to them or their scale is lacking. In the PROFIR project in **Uganda**, the CSPE highlighted that women expressed challenges in persuading their husbands to use their **land as collateral** for obtaining loans from savings and credit cooperatives or commercial banks. This was also the case in the **Kenya** project KCEP-CRAL, where nearly all women interviewed reported there was strong resistance from the men to cede land to be used as collateral for bank loans. The PCRV of CRPR project in **Vietnam** indicated that there was an oversight regarding addressing concerns of ethnic minorities women who were reluctant to secure loans because of the burdensome paperwork it involved.

Support to link rural women to value chains/transition from subsistence to commercial farming:

Good practices/results: For instance, this was done in **Argentina** PRODECCA (goat value chain) and various value chains for PROCANOR. Rural Adelante in **El Salvador** identified and prioritized value chains showing higher gender gaps/issues, which could be addressed using Cerrando Brecha (see below).²⁸⁵

Cambodia: women concentrated in chicken and vegetable VC. Some anecdotal reporting that men took over their business when the scale was bigger and the business more profitable; **Türkiye**: milk VC, greenhouses for women to help them get surplus.

Limited results: self-reporting or available evidence just focused on outreach of rural men and women.

Technical and vocational training:

Good practices/results: Examples from 13 of the 23 IOE evaluations synthesized in this TE include training in agriculture and livestock production, climate-smart agriculture or other forms of vocational and entrepreneurship training. The emphasis on training, in some cases for rural women, was also prevalent in the projects examined in the country case studies.²⁸⁶

Sudan: literacy on agronomy including investments and farm yields; **Cameroon**: Agri-nutrition trainings to use other cereals and grains as substitutes for wheat or maize-based snacks bought from markets long distances away; **Kenya**: Organizational + nutritional training; **Tunisia**: Women's training to enhance their project management and operational skills, some of whom became trainers themselves; **Mauritania**: entrepreneurship and management training.

Limited results: it is not always clear if the training is adapted to the different needs of various groups of rural men and women, or their constraints to participate and benefit from.

Income-generating activities, backyard gardens and small off-farm activities:

Good practices/results:

The PCRVs of **Ethiopia** PCDP III, **Mexico** PROINPRO, **China** YARIP, **Nepal** KUBK/ISPF; **Senegal** PAFA-E, **Uruguay** PPIR and **Cambodia** PADEE.

²⁸⁵Sixteen farmers' organizations in the dairy and aquaculture sectors were prioritized because they showed low (<40%) participation of women and youth; limited access to project services, high percentage of women with low self-esteem or reported issues of sexism and gender violence. Source: report on the implementation of Cerrando Brecha 2022-2023.

²⁸⁶**Sudan**: literacy on agronomy including investments and farm yields; **Cameroon**: Agri-nutrition trainings; **Kenya**: Organizational and nutritional training; **Tunisia**: Women's training to enhance their project management skills; **Mauritania**: entrepreneurship and management training. In **Tunisia**, the development of telecentres supported by IFAD provide access to information, technology, and online services, reported as beneficial for women living in remote areas or with mobility constraints, enabling them to connect to a wide range of services and opportunities.

Tunisia: family poultry farming, greenhouse cultivation, and dairy goat farming (it is reported that young women got **preferential conditions** to access IGAs promoted by IFAD); **Cambodia:** chicken and vegetable VC development + improved market access; **Argentina:** Support in creating business plans for women-only groups; **Sudan:** in IAMDP, extension workers target women with microfinance/subsistence projects; **Cameroon** PEA-J focused on young rural entrepreneurs; **Mauritania:** vegetables and chicken IGAs.

Off-farm activities: **Cambodia** (weaving), **Argentina** (some investments of PROCANOR/PRODERI, Cameroon (some young entrepreneurs of PEA-J), **Mauritania** (some women doing handicrafts); CSPE **Madagascar** reported IGAs related to handicrafts.

Limited results: they do not challenge the constraints faced by women to produce at a larger scale or analyse the additional burden for rural women.

SO2: IFAD interventions and the promotion of gender-equal decision-making and representation

Men/women quotas in management committees of producers' organizations:

Good practices/results: more than half of the projects in the TE country case studies reported this,²⁸⁷ which was also found by the 23 IOE evaluations reviewed and the previous evaluation synthesis in 2017.

Cameroon: 30% of women in the boards of POs; **Tunisia:** PRODEFIL contributed to the creation of two women-led Agricultural Development Groups (GDAs) and supported the development of their business plans. Women also hold 20% of the positions on GDA boards (95% above target, women now representing 30% of GDA members, **Türkiye:** more women in cooperatives decision-making bodies, one project also established an only-women cooperative, but only anecdotal reporting; **Mauritania:** support to women to participate as members of the management committees of cooperatives and oasis development associations. **India:** Community Managed Resource Centres are a model of a self-financed apex organization led and managed by women themselves, which operate independently, raise money via membership fees, service charges for inputs, training, commission from business correspondents, make their own plans and budgets, and operate like a business.

Potential best practice, but limited implementation:

Cerrando Brecha²⁸⁸ in El Salvador. According to desk review and interviews, this methodology has been fully applied in 24 organizations in **El Salvador** through two IFAD-supported projects. The reported number of individuals trained using *Cerrando Brecha* is limited (around 2,500 people).²⁸⁹ Beneficiaries interviewed for the IOE field mission in 2023 shared their concerns about a long process to identify affirmative actions which then get a very small funding (USD 1,500-5,000, on average). In addition, the women interviewed by IOE in **El Salvador** reported that, despite the use of CB, decision and control over income by women still remain challenging. Similar results were

²⁸⁷ Some IFAD projects in **India** support self-financed apex organizations led by women themselves (Community-managed resources centres), or women-led agricultural development groups in **Tunisia**, or women-only organizations (En Nuestras Manos-PROCANOR in **Argentina**).

²⁸⁸ According to interviews for the TE, the methodology was created in **Guatemala** and validated in other IFAD projects in the **Dominican Republic** and **El Salvador** around 2003. More recent projects using the methodology are Rural Adelante in **El Salvador** in 2021, Procamelidos in **Bolivia** in 2022 and FAREPS in **Ecuador** in 2022. Likewise, it is expected to be applied in **Ecuador** DESATAR, **Dominican Republic** PRORURAL and **Argentina** PROSAF.

²⁸⁹ CB was validated in PRODAP-II (1999-2008) and used in MAG-PRODEMOR Central (2007-2019), reaching 2,409 people (57 per cent women), and in Rural Adelante (2015-2023), reaching 271 people (34 per cent adult women and 13 per cent young women). According to interviews with the Ministry of Agriculture/PMU staff, CB was not fully implemented in Amanecer Rural (2012-2018), it was only mentioned as part of gender-related training. The 2015-2019 COSOP (extended to 2022) mentions the use of lines of action, related to affirmative actions in projects for this subgroup of targeted population. Examples include funds for productive activities and training for gender awareness or organization management training, literacy, childcare, household discussion on roles distribution.

found by the capitalization of the **Honduras** EMPRENDESUR in 2019, as well as constraint due to limited access to land and technology for rural women.

Promoting rural women participation in public local/village governance structures:

Good practices/results: cases of young women trained by IFAD projects taking local authorities' position (**Cambodia, India**²⁹⁰), Some projects in **India** proposed creating alternate community institutions with high women's representation, instead of challenging the male-dominated traditional local councils. Also support to women to engage in the territorial diagnostics related to local development planning (**Mauritania**), participation of women in village development committees and women interest groups (**Sudan**): promotion of women's interest groups (e.g. on livestock and forestry), SNRLP aims at reaching 40% representation of women in CDCs, village development committees and NRCs.

SO3: addressing unequal workloads and shared benefits

Infrastructure and equipment:

Good practices/results: **Ethiopia**: infrastructure for women's access to water sources for human and livestock; **Tunisia**: private water tanks; **India**: energy-saving technologies (solar water heating, house thermal insulation, and access to village stone bakeries for bread making); **Sudan**: carts and pumps to collect water; net houses in **Cambodia** and **El Salvador** (less time and effort on weeding and watering), pens to reduce time on herding goats in **Argentina**, fishponds and aquaculture in **Sudan** and in **Kenya** (reducing walks to far away lakes), and milk collection centres in **Türkiye** (reducing time spent transforming milk to avoid waste of unsold milk).

Labour-saving machinery: **Cambodia**, new technologies for egg-hatching and brooding; **Türkiye**: electric grape juice extractors and sewing machines, **India**: milking machines.

A grant to mobilizing public private partnerships supported the introduction of small electric spinning machines in women-led small businesses in mountainous regions of **Tajikistan, Afghanistan and Kyrgyzstan**.

Childcare and support to rural women with other caregiving responsibilities:

Cameroon young mothers receiving intensive training through an incubation programme of PEA-J) and proposed in **Argentina**,²⁹¹ **El Salvador** mentions childcare support as potential affirmative action to be funded by projects, but not reported.

Additional information on GEWE practices contributing to open spaces for rural women and men to challenge and change social norms causing gender inequality:

Leadership training for rural women: in five of the 23 IOE evaluations (**Ethiopia, Mozambique, Nepal, Rwanda, Sao Tome and Principe**) and in projects included in the case studies (**El Salvador, India, Tunisia, Kenya** and **Türkiye**).

In eight of the eleven country case studies cases, gender awareness training is provided for both rural men and women, and for Project staff²⁹². In **India**, several IFAD projects have taken steps beyond gender sensitization of men in the community, promoting men as champions or advocates for gender equality, and addressing sensitive issues such as violence against women. In **Sudan**, following the mid-term review of LMRP, there was

²⁹⁰ **India**: FOCUS Mizoram had a target of 50% female representation in community institutions, but managed to reach only around 30%. JTELP introduced Gram Sabha project execution committees (GSPEC), with strong representation of women (at least 50% women and at least one of the three signatories to be a woman) to identify needs and implement project-related activities at community level. The programme has elected to create alternate community institutions, rather than challenge and transform male dominated traditional councils that hold power and control

²⁹¹ **Argentina**: PRODERI's design included some budget for housekeeping and childcare for female project participants, but no evidence was found of its implementation.

²⁹² **Cambodia, Mauritania, Cameroon, Ethiopia, Argentina, Kenya, Tunisia, El Salvador**.

an increased focus on engaging men. Continuous awareness and sensitization of the community is required as women were not allowed to participate in public meetings.

Some projects promote valuing women’s productive contribution in rural settings to foster their empowerment and community/household recognition.

The use of agroecological logbooks in IFAD projects in Brazil values the contributions of women engaged in family and agroecological agriculture. According to self-reported data, this practice facilitates tracking of women's production and recognising their often-overlooked contributions.²⁹³

The evidence about the outcomes of sensitizing and engaging with men in communities as a tool for gender inequality is scant. Numerous reports emphasize that excluding rural men from gender equality initiatives poses a potential risk of backlash and can undermine the sustainability of GEWE outcomes.²⁹⁴

Some projects have fostered the involvement of rural women beyond the confines of their communities and villages to create role models. Illustrative examples include projects in **El Salvador**, where women were supported to participate in the national rural women’s roundtable. Additionally, initiatives like women-only discussion groups for technical and management support have been implemented in **Tunisia** and **Argentina** and self-help groups promote women’s financial decision-making and their mobility outside the home (**India**). Discussions with diverse stakeholders during the TE indicate that these women are regarded as role models within their communities, potentially empowering other women.

Other IFAD-supported projects to promote **women’s involvement in activities traditionally reserved for men** observed in **Tunisia, Türkiye and Kenya.**²⁹⁵

Initiatives such as training and recruitment of women as farmer extensionists, local community or municipality elected officials, have been implemented in **Cambodia, Tunisia, Türkiye, Mauritania, India** and **Sudan.**²⁹⁶ In addition, projects in **Tunisia** and in **Sudan** are involving rural youth, particularly young women, in key project activities.

Household methodologies have been used in almost one hundred IFAD projects, with contributions to the three strategic objectives of the gender policy and also as a targeting strategy.

Box 28

Results (or outputs) linked to the use of GALS (or other HHM).

- Strategy to reach men/women quotas among project participants or specific vulnerable groups among them (Nepal RERP and ASDP, Kenya KCEP-CRAL, Rwanda RDDP, Kirgizstan AMP, Sudan SNRLP, Gambia ROOTS, Nigeria VCDP).
- Results related to SO1: Joint access and control of large stock animals (Nepal ASDP), joint ventures by men and women of the same household (Kenya KCEP-CRAL), women’s influence on men’s behaviour to rationalize expenditures in favor of the household (Sudan LMRP), other SO1-related effects (Kenya TE field mission, JP-RWEE evaluation in Nepal and Kirgizstan).
- Results related to SO2: more women participation in governance structures of producers or self-help groups (Nepal ASDP, Kenya KCEPRAL and ABDP), in village public meetings (Malawi PRIDE, Sudan SNRLP, Nigeria VCDP, Kenya KCEPRAL, JP-RWEE evaluation). The reporting also mentions benefits in relation to more equitable intra-household decision-making (Uganda

²⁹³ This practice/methodology was used in the Paulo Freire Projet (2012-2021) with 909 women in 112 municipalities. IFAD. 2021. Analysis of One Year of Use of Agroecological Notebooks in IFAD-supported Projects in Brazil.

²⁹⁴ JP RWEE Final Evaluation (2021), Global Food Security, volume 37, June 2023, Assessing multicountry programs through a “Reach, Benefit, Empower, Transform” lens found it lacked a strategy to engage with men.

²⁹⁵ **Women taking male-dominated rural jobs: Tunisia:** in PRODEFIL, women engaged with traditionally male-dominated activities like camel/chameleon farming, carpentry, and greenhouse cultivation. This transformation allowed women to participate freely in national fairs and international events; **Türkiye:** women engaged in tractor and truck driving, **Kenya:** commercialised cereals farming (KCEP-CRAL), commercialised livestock production (KELCOP) and fish farming (ABDP). Similarly, men ventured into female-dominated activities such as chicken production and fish retailing.

²⁹⁶ **India:** female vets recruited as extension workers; women as para-vets in **Sudan; Türkiye** GTWDP recruited female trainees. This was not implemented but recommended by rural women interviewed by IOE in **Mauritania** in 2023.

PRELNOR, Rwanda RDDP, Kenya UTaNRMP, Malawi PRIDE, Nigeria VCDP, Kenya KCEPRAL and ABDP.

- Results related to SO3: re-distribution of household tasks after GALS training, such as more time devoted by men to reproductive roles²⁹⁷.

Source: TE country case studies and desk-review of 74 projects including HHM/GALS.

Common reported challenges for HHM implementation include limited budget and PMU capacities and difficulties recruiting trained HHM practitioners. Issues related to the recruitment of gender and social inclusion project staff or the HHM contractors are frequently mentioned. Budget constraints are also identified as a limiting factor for HHM implementation. Limited capacities, absence or overstretched gender PMU experts are significant hindrances to HHM implementation²⁹⁸. International NGOs or a consortium with local NGOs are commonly identified as the primary HHM service providers. In various cases, supervision reports recommended engaging other key actors to ensure correct HHM implementation²⁹⁹.

²⁹⁷ The impact assessment of UTaNRMP in **Kenya** (2021) found that the average time spent on reproductive roles by men increased from 8 hours to 10.5 hours, while the average time spent on work by women reduced from 16 hours to 12 hours. However, this assessment does not distinguish the effects of the use of GALS from other project-supported activities. Participants in focus groups during the TE field visits in **Kenya** in May 2023 also reported certain tasks being now more shared among men and women (and young members of their household), without quantifying their time. Other reports only provide generic statements in terms of reduction of women's workload (**Kenya** KCEPRAL and ADP, **Malawi** FARMSE and PRIDE, **Rwanda** RDDP, **Uganda** PRELNOR, **Sudan** SNLP, **Ghana** GASIP, **Uzbekistan** DVCDP).

²⁹⁸ The IFAD 2014 how-to-do note and the 2019 stocktake exercise in 2019 also warned about the limited staff capacities and budget for HHM implementation and recommend to link HHM with project M&E system to further capture GALS-promoted changes. The absence of PMU expert to champion HHM implementation was mentioned in documents of **Papua New Guinea** MVP, **Zambia** E-SLIP, **Ghana** REP, **Sierra Leone** RFCIP II.

²⁹⁹ Other actors recommended to be involved in HHM implementation are universities (**Nigeria** VCDP), government authorities in charge of gender issues (**Sierra Leone** AVDP, **Burkina Faso** PADFA).

Factors affecting GEWE performance of IFAD interventions.

Figure 23
Prioritization of factors affecting GEWE performance at IFAD, by the 28 participants to the TE design workshop (March 2023)

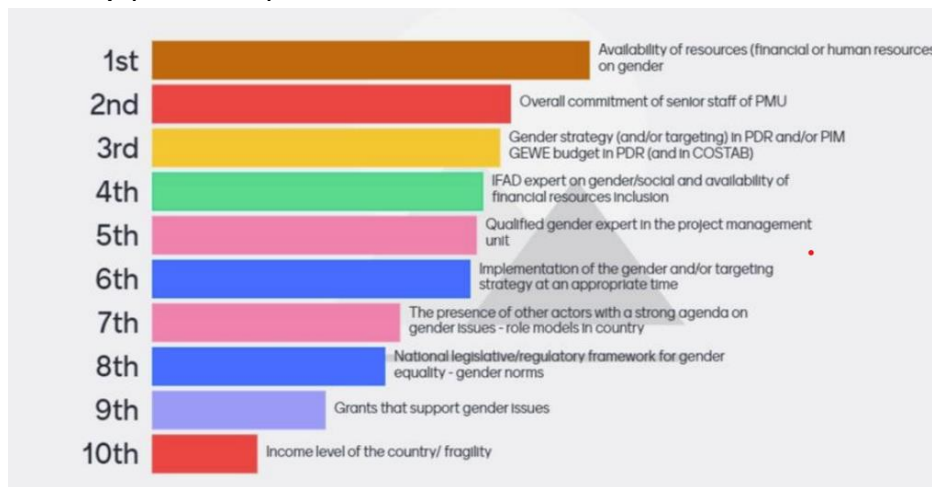

Additional information about the results from the use of Qualitative Comparative Analysis to completed projects (see more information about the methodology in Annex 4):

Additional information of the **three models with five conditions** that lead to high or low gender rating found when applying QCA to the 28 completed projects and approved after the gender policy. The conditions are a combination of the four types of GEWE practices and some contextual conditions.

The **first model** found that in low-income countries, having a project gender strategy makes the difference between high and low gender rating when projects do not include activities related to voice & representation and equitable workloads. With the absence of the same GEWE practices, in higher income countries, in addition to the project gender strategy, the PMU gender expert makes the difference to explain high/low rating.

Figure 24
Venn diagram for the 1st model with two types of GEWE practices (related to SO2 and SO3) and three contextual conditions (V7, V10, V11) for the expanded dataset

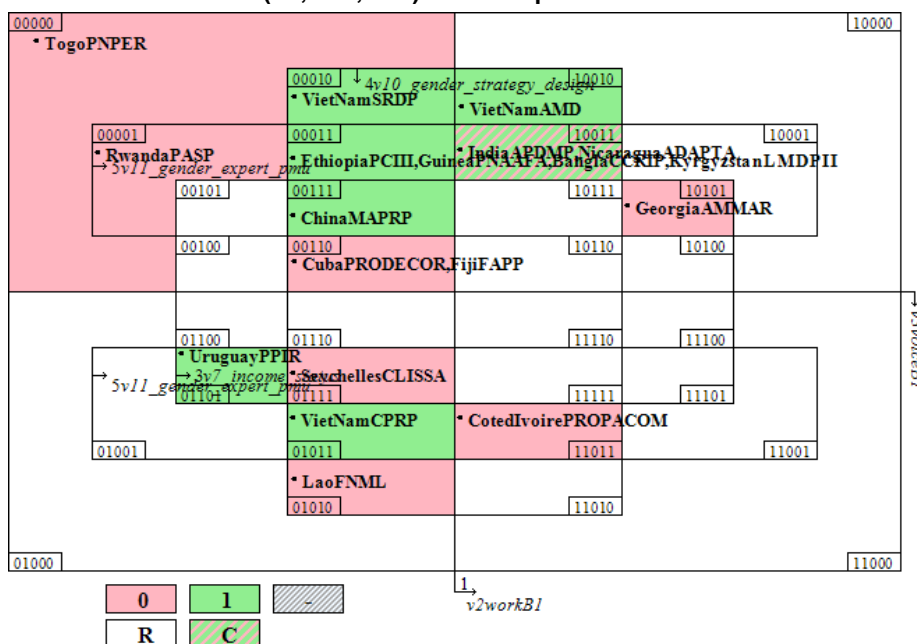

The **second model** tested the combination of the presence of the three types of GEWE practices that are directly linked to the IFAD policy objectives (voice & representation, equitable workloads and economic empowerment) in the project, along with project gender strategy and PMU gender expert (regardless of the income level of the country where the project was implemented). This confirmed the **importance of the project gender strategy and the PMU gender expert**. Only the three projects in Vietnam were an exception, scoring high without a formal PMU gender expert (but with the special implementing partners mentioned before above). For the three Vietnam projects alone, the presence of the GEWE practices related to economic empowerment led to a high gender rating. This was not found in any other country/project.

Figure 25
Venn diagram for the 2nd model SO1, SO2, SO3 GEWE practices and project gender strategy and PMU gender expert (V1 V2 V3 V10 V11) (tested on the expanded dataset)³⁰⁰

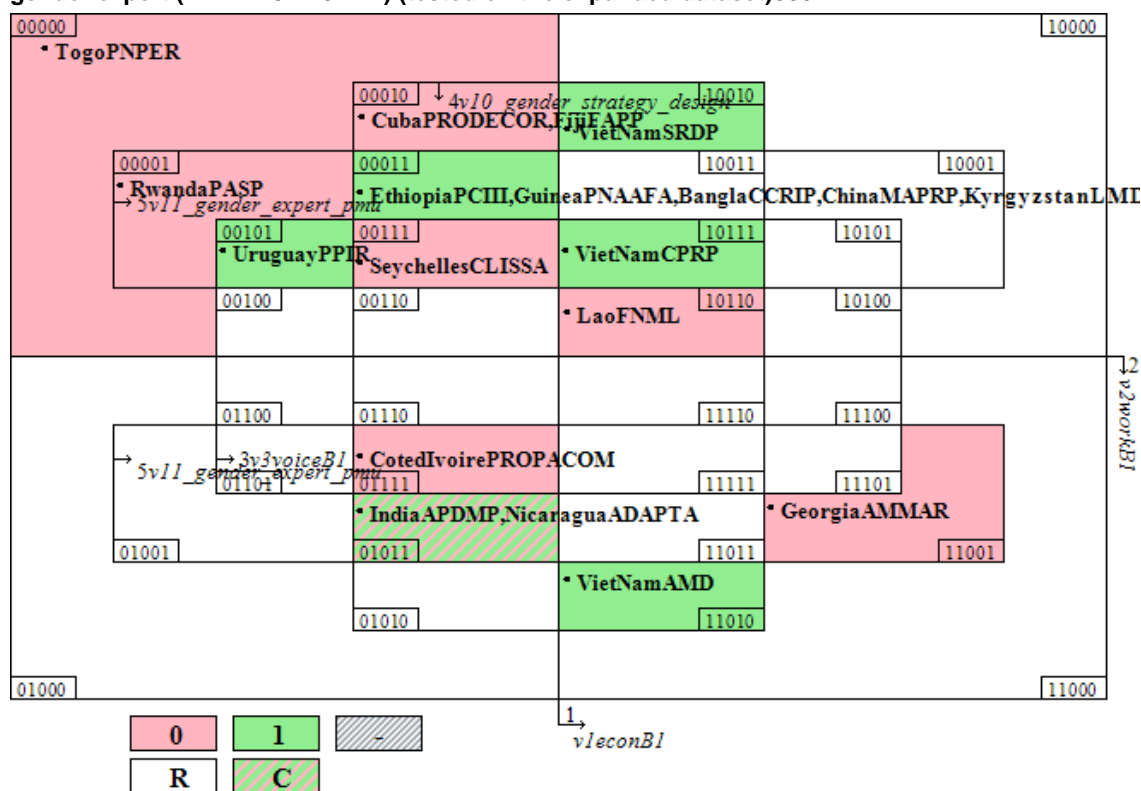

The third model included this fourth type of GEWE practices of the QCA framework and four contextual factors. The inclusion of GEWE practices trying to influence norms and culture do not explain the gender ratings of these completed projects. These results need to be considered with caution because the number of completed projects including these GEWE practices is very low. Some subpractices are not included in the 16 or 19 cases explored using QCA because they are rated 4. In addition, the reporting of these types of practices in projects approved before 2019 and not validated as Gender Transformative by IFAD may still present challenges due to low knowledge from gender consultants and other staff to capture them in the Project Completion Reports.

³⁰⁰ Similar results were found for the main dataset (16 cases), but they were slightly more difficult to be read. Legend: R logical combinations not present in the cases analysed; C means contradiction, that is a combination covering multiple cases that do not present a consistent value of the outcome (the combination is associated with both positive and negative cases); 1 means combination leading consistently to a positive outcome; 0 means combination leading consistently to a negative outcome.

Figure 26
Venn diagram for the 3rd model, including Gender Transformative-related practices, V7, V10 V11, V13 (tested on the expanded dataset)

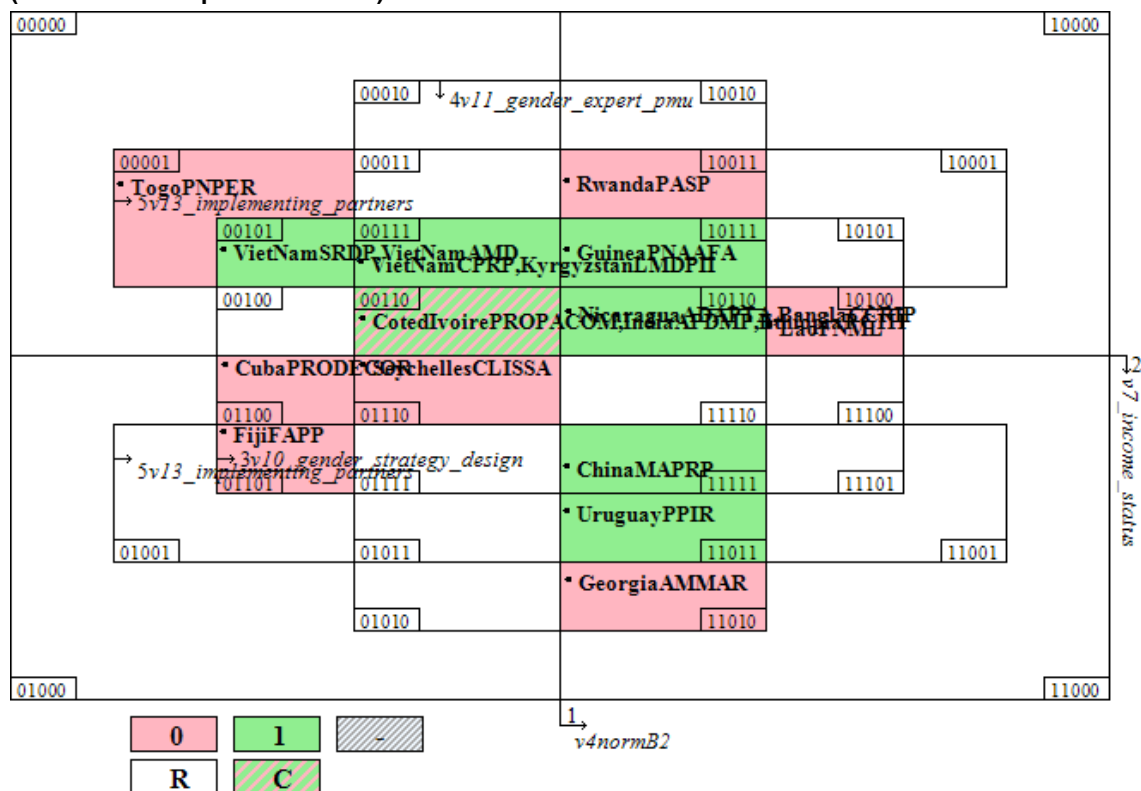

The analysis also used the **subtypes of GEWE practices and found a five-condition model which explains projects with high gender rating**. This model kept two contextual conditions (**project gender strategy and PMU gender expert**) and three GEWE subtypes of practices: one related to representation & voice (Q3a: **promotion of more equal participation in cooperatives and similar organizations**-mainly enforcing men/women quotas in their boards), one related to equitable workload (Q2a: **time saving infrastructure**) and a third related to norms (Q4e: **inclusion of leadership training for women and men**). This model did not include any subpractice related to economic empowerment.

Evolution of the country gender inequality in the case studies

Figure 27

Gender Inequality Index (GII) comparison of the countries selected for the case study in 2013, 2017 and 2021

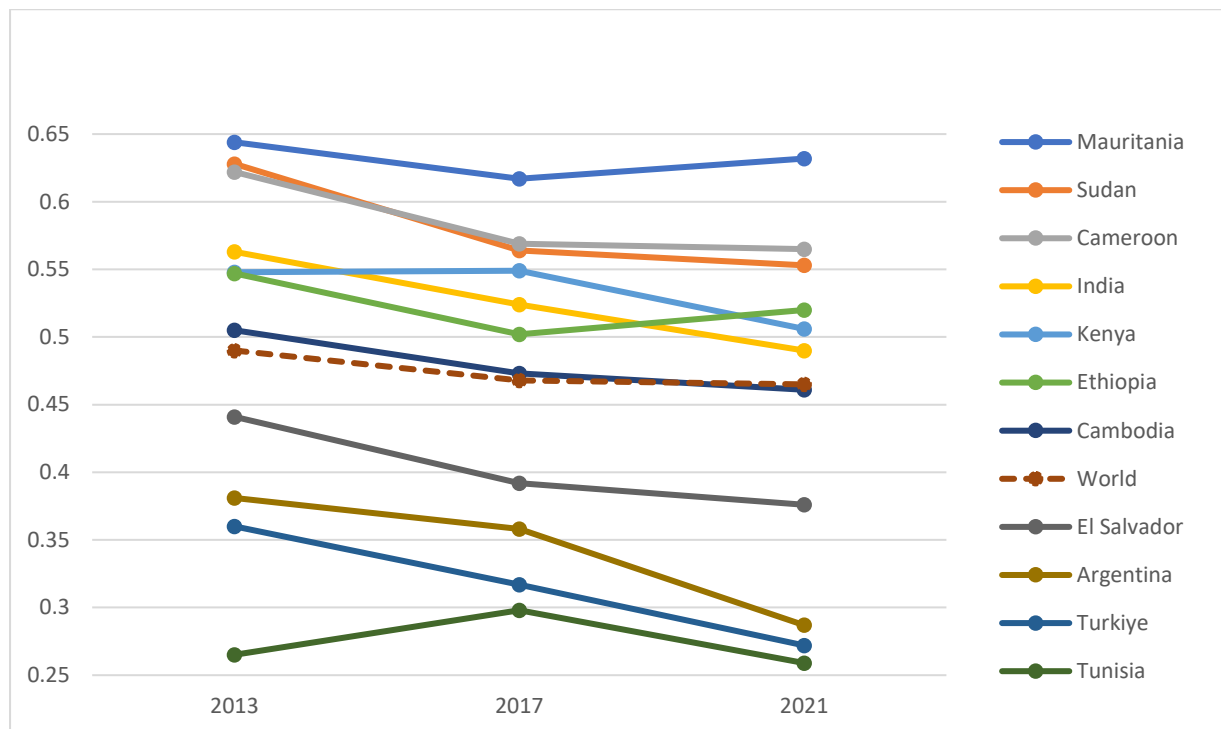

Sources: UNDP, HDR 2014; UNDP, HDR 2017; UNDP, HDR 2021-22

The **Gender Inequality Index (GII)** is a composite metric of gender inequality using three dimensions: reproductive health, empowerment and the labour market. Its value ranges between 0 and 1 and a low GII value indicates low inequality between women and men. GII is based on the following indicators: (i) maternal mortality ratio, (ii) adolescent birth rate, (iii) female and male population with at least secondary education, (iv) female and male shares of parliamentary seats and (v) female and male labour force participation rates. The index is national, it does not show disaggregated urban/rural data. The 2021 figures do not seem to fully capture yet the negative effects of the pandemic on gender inequality, as various reports highlight.

Other gender gap indices were considered, such as WEF'S Global Gender Gap Report (**GGGR**), OECD's Social Institutions and Gender Index (**SIGI**) and UNDP's Gender Development Index (GDI). However, several considerations led the TE Gender team to select the GII as the primary metric to describe the overall trend of gender gaps in the 11 selected countries, for the 29 completed projects analysed in the QCA analysis and for the 100 countries with projects with IOE evaluations. These include the issue of data completeness and comparability. The GGGR and SIGI exhibited considerable data gaps, making it challenging to provide a comprehensive and consistent overview of gender inequality across all countries during the evaluation period³⁰¹. Another reason contributing to the exclusion of SIGI was its change in methodology and indicators across the 2014, 2019 and 2023 editions which limited its comparability throughout the years³⁰². Furthermore, the GDI was not selected due to the distinct focus of the GII on

³⁰¹ In GGGR 2023 (last available) there is no data reported for five of the 29 QCA projects as well as for Sudan and Mauritania, two case study countries. In SIGI 2019 there is no data reported for seven of the 29 QCA projects as well as for Argentina, Sudan and Mauritania.

³⁰² Each edition of OECD's SIGI included different numbers of indicators (21 in 2014, 27 in 2019 and 25 in 2023). While the 2014 edition measured indicators across 5 dimensions, the 2019 and 2023 included the following four dimensions: discrimination in the family, restricted physical integrity, restricted access to productive and financial resources, and restricted civil liberties.

capturing gender disparities. The GII offered a more nuanced portrayal of gender gaps by including indicators such as male and female representation in political institutions and male and female labour participation. Consequently, the GII emerged as the most suitable and comprehensive metric for displaying gender gaps, due to its greater data coverage and attention to gender inequality trends in the selected countries.

Additional information about the performance of IFAD's non-lending activities for GEWE results

GEWE -related knowledge management and partnerships:

Despite its limited size of human resources, IFAD has been quite active introducing gender issues in international fora and in international working groups. For instance, IFAD has been participating across the years in the Commission on the Status of Women; the RBA collaboration on the International Day of Rural Women and other ad-hoc seminars and events. It has also engaged in the Multilateral Development Banks Group on Gender, the United Nations Inter-Agency Network on Women and Gender Equality, the OECD-DAC Gender Network and the Global Donor Platform for Rural Development. Recent engagements include supporting the development of globally accepted "Voluntary Guidelines on GEWE in the context of food security and nutrition", under the leadership of the Committee for Food Security. IFAD also co-led the Generation Equality Action Coalition on Feminist Action for Climate Justice.

IFAD maintains a dedicated [webpage on gender](#) where various knowledge products, guidance, stories, and news are accessible, predominantly in English. According to analysis of the IOE CLE on KM (2024 forthcoming), since 2016, IFAD has produced 49 publications on gender, well behind the 116 publications referring to climate and environment, and behind rural finance and nutrition. As of December 2022, the gender product with most views is [the teaser for the Poverty targeting, gender equality and empowerment toolkit \(2017\)](#),³⁰³ followed by the [2022 HTDN about the integration of GALS in IFAD operations](#). These two key gender knowledge products are also available in Spanish, French and Arabic. The Spanish and French versions have the most downloads of these two publications, followed by Arabic. RIDE reports (2013-2023) also mention the inclusion of gender in various communication channels, including the IFAD gender website, videos, regional newsletters, photo essays and web stories.

In the results of a google search for 'gender and rural development' in February 2024, IFAD appears in the top 30 in the results. IFAD came 10th when searching for 'gender and smallholder farming' with a link to an IFAD success story on [gender and rural women](#). In Spanish, IFAD appears after FAO, UN Women and the Spanish Ministry of Agriculture when using similar keywords in google; while in French, it only appears when using 'rural poverty and gender' or 'small agriculture in gender', but always behind FAO resources.

Effective use of IFAD GEWE resources may face challenges due to a potential language issue. As the IOE CLE on KM found, many knowledge products are only available in English.³⁰⁴ A significant number of the TE e-survey respondents, among the 574 PMU staff and 181 PMD staff/consultants noted translation issues for key gender-related concepts into other language (63% for PMU³⁰⁵, 67% for PMD respondents). This challenge could be interpreted in two different ways: the prominence of English above other UN-languages as reflected in the need of the IFAD gender glossary in 2017 and 2021, and the difficulty of translating these concepts into local languages spoken in rural areas where IFAD operates. For example, case studies in **Kyrgyzstan, Vietnam, Côte d'Ivoire** and **DRC** from the IOE CLE on KM (2023 forthcoming) confirmed that the prevalent use of non-local languages in IFAD official documentation hinders engagement with local communities and knowledge dissemination.

³⁰³ A 12-page introduction to poverty targeting, gender equality and empowerment relevant for IFAD investments. It is supported by How to do notes at design and during implementation, which have less views (486). According to RIDE 2022, this toolkit was among the top three downloaded corporate knowledge in 2021.

³⁰⁴ By the end of 2022, of the 909 knowledge products (full-text publications) available on the IFAD website with download links, 74 per cent are in English, 10 per cent in Spanish, 12 per cent in French, and 4 per cent in Arabic. The main categories of the published knowledge products in languages other than English are Toolkits and Annual Reports.

³⁰⁵ For example, reported problems with translating key gender terms into other languages were highest in NEN (69%), APR (67%), ESA (66%), and WCA (64%) and lowest in LAC (48%).

Certain gender grants during the evaluation period played a role in generating and disseminating knowledge, which could be further enhanced. The creation of online platforms facilitated general information dissemination, but findings indicate they are more advantageous for development practitioners and national stakeholders, as rural women and men often encounter challenges related to internet connectivity. For instance, this is the case of the Empower@scale platform for GALS set up by Hivos & Oxfam Novib. The Taqem initiative in **Tunisia** reported a sustained practice of knowledge sharing from their community of practices³⁰⁶. The CIFOR grant produced socio-legal studies on gender and land tenure in seven countries and expects to start policy engagement activities in 2024. Interviewees shared good practices implemented to enhance the uptake and utilisation of knowledge products generated through grants. For instance, in relation to the topic of “water”, a grant knowledge stock-take workshop was organized and a short note produced with evidence on the issue, relevant policies and procedures and ways to incorporate this knowledge in IFAD investments or apply for a subsequent grant.

The limited integration of global and HQ-managed gender programmes and grants into COSOPs and IFAD-supported projects restricts their potential to influence country-level gender policy changes. Various factors were identified: (i) joint programmes and supplementary funds following a different process than IFAD investment projects and work with different administrative systems across the partner agencies, (ii) IFAD-supported projects have much larger budgets than the funds from supplementary funds in a specific country, hence receive less priority at the country level. Self-assessments of the JPs confirmed some of these issues,³⁰⁷ (iii) high turnover of key IFAD staff hindered the creation of linkages with ongoing projects, (iv) lack of interaction between smaller grant executing agencies and IFAD staff also means the former is not familiar with IFAD’s approach to GEWE.

Through an IFAD grant ([Semear International Program](#)), the *Cadernetas Agroecologicas* (Agroecological books) methodology tested in **Brazil** IFAD’s portfolio was discussed in Brazilian universities as well as with technicians and farmers from Portuguese-speaking African countries (**Angola, Mozambique, São Tomé and Príncipe**)³⁰⁸. This methodology is expected to be used in 2024 in an IFAD-supported project in Sao Tomé and Principe.

Prospects of sustainability and scale up of GEWE practices, including policy influence

Partnering with NGOs and other service providers is important to the effective implementation of gender approaches. A partnership with Oxfam Novib since 2009 through various IFAD grants developed and promoted the roll-out of GALS in various African countries. **Ethiopia’s** adoption of Gender Model Family (GMF) approach has resulted from partnerships with various organizations, including CIFOR. CIFOR also implements the global grant on Women’s Land Rights Initiatives. IFAD has also partner with the International Land Coalition in various settings and globally. Additionally, NGOs such as CARE, World Vision, and IFPRI have contributed to pilot gender innovations through grants of IFAD-funded projects.

³⁰⁶ Grant funds were used to launch calls for proposals for gender mainstreaming as well as approaches to impact evaluation. WEAI was tested in Tunisia - the first time WEAI has been used in an Arab country. The grant developed a platform (now disabled) to share learnings among NGOs practitioners, governmental organizations and researchers. According to TE interviews, individuals from 12 organizations are still in contact with the programme coordinator noting that capacity building helped the M&E tasks of their projects confirming to some extent the sustainability of the grants awarded through Taqem.

³⁰⁷ The **JP RWEE Phase I** self-assessment found that IFAD country presence in target countries was important to facilitate implementation, but was uneven. There was a lack of coherence across participating agencies’ administrative systems. Delays are still noted in JP RWEE Phase II. The EU’s Results Oriented Monitoring of the **JP GTA** in 2022 also raised the point about the need for commitment among country project staff to engage in GTA activities.

³⁰⁸ IFAD. 2022. *Productive Development and Capacity-Building Project, project completion report and <https://www.ifad.org/en/web/latest/-/brazil-agroecological-logbooks>* accessed on 28/11/2023.

Additional information about the assessment of sustainability of efforts for the sustainability/scale-up of HHM (GALS) after IFAD support:

- GALS champions and trained farmers motivated to continue with activities after project completion: **Sudan** LMRP; JP-GTA supported GALS experience in **Ecuador**; TE confirmed instances of farmers themselves disseminating GALS in some visited counties in rural **Kenya**.³⁰⁹
- Challenges for continuation of GALS activities after IFAD support: **Uganda** PRELNOR, there is a recommendation for refresher trainings, particularly to emphasize the necessity for follow-up activities with graduated households; in other cases, it is not clear if partnerships are secured to ensure the continuation of GALS.³¹⁰
- There are ongoing efforts to enhance in-country HHM capacities to ensure replication and adaptation to local contexts. Currently, only the one in **Uganda** demonstrated more sustainability compared to those in **Kenya** and **Nigeria**, mainly thorough the initiation of income-generating activities. Consolidating a pool of trained HHM facilitators is one of the challenges to ensure sustainability and ease the replication and scale up of these methodologies without relying on international consultants.
- Scale-up of GALS by government institutions: The **Nepal** government buy-in and policy influence of GALS, after the JP-RWEE support, was highlighted in interviews and by one respondent to the e-survey for this TE GEWE³¹¹. Other examples, include the adoption of GALS by the **Malawi** Department of Agriculture Extension Services; the integration of household mentoring methodology and GALS into the **Uganda** National Parish Development Model; and the roll-out of GALS in **Rwanda** through farmer field schools, according to self-assessments.
- Additionally, interviewees, including grant officers, warned about the risk of trying to fit HHM in all contexts. GALS was given as an example of working well in some African countries, but visualisation (and role-play) may work less well in Central Asia or Latin America.

Interviews conducted for the TE revealed that there was no formal strategy to disseminate Cerrando Brecha to other countries in the region or beyond. In **El Salvador**, key actors involved in implementing Cerrando Brecha reported efforts to train staff from other national institutions not directly linked to IFAD projects to use the methodology. However, key practitioners acknowledged that the methodology has been dependent on PMU staff and project funding. In 2021, after a consultative process, this methodology underwent an update to incorporate features to facilitate its upscale. The approach seeks to create a pool of local trainers who are able to adapt the underlying principles of the methodology to ensure sustainability.³¹² In August 2022, a [South-South training of trainers of Cerrando Brecha](#) was held in **Ecuador**, strengthening the capacities of 33 leaders from rural associations and technicians from public institutions, as part of the JP GTA.

Examples of project-funded activities to influence policies for GEWE: For instance, in **Argentina** the PRODECCA project conducted a study on the role of women and the youth in the goat value chain fostering regional discussion platforms around this

³⁰⁹ Trained farmers are training their spouses and children and other church/social welfare group.

³¹⁰ In **Madagascar** FORMAPROD documents highlight agreed actions with state institutions responsible for women's empowerment to continue GALS. Others recommend this in the supervision missions: **Chad** Renfort and **Gambia** Roots.

³¹¹ The impressive transformative results from partnership on GALS generated interest from **Nepal** elected provincial and local leaders to have committed funds to scale-up and replicate these initiatives as a direct influence on practical sub-national policy and public investment" (PMD respondent).

³¹² The revised methodology now includes modules for training of trainers aiming to enable its application by individuals with a basic background in gender issues and group management. Moreno Ana Lucia. 2022. *Laboratorio técnico Cerrando la Brecha de Género*. Webinar 30 de junio del 2022.

value chain. A similar initiative was undertaken in **El Salvador**. In **Tunisia**, projects such as PRODEFIL and PROFITS have reportedly engaged in activities to influence policies, although specific details on the approach are not provided. In **India**, the Nav Tejaswini project made advancements in joint land ownership.

Findings about how GT-validated PDRs plan for policy engagement: China
H2RDP vaguely highlights coordination with national partners to introduce gender-responsive policy shifts, particularly in the context of the farmer training program.³¹³ Other GT PDRs only mention political dialogue focused on youth (**Cameroon** PADFA II), while others make no mention of any attempt in this regard (**Zimbabwe** SACP, **China** Y2RDP, **Morocco** PRODER, **Cambodia** ASPIRE-AT).

³¹³ IFAD adopted a result-based lending approach to incentivise the county to train more farmers, especially women, by releasing more funds as counties train more female farmers.

Table 31
Organizational context and human resources dedicated to gender since 2012.

	2012-2014	2015	2016	2017	2018	2019	2020	2021	2022	2023 to-date
Context										
Key organizational changes/strategic documents	2012 GEWE Policy		Mid-term review of GEWE policy Gender mainstreaming in IFAD10 document		PTA (under PMD) split into PMI and ECG (under SKD) Mainstreaming gender, youth, nutrition, environment & climate change. New PDT process Decentralization Re-assignment exercise	Mainstreaming GTAs, action plan (2019-2025)			Disability inclusion strategy approved	2023 (Revised) Poverty Targeting Policy Re-assignment exercise
Director responsible for thematic/mainstreaming areas, including gender and social inclusion team			Director 1 (PTA)	Director 1 (PTA)	Director 1 (PTA)	Director 2 (ECG)	Director 2 (ECG)	Director 3 (ECG) /	Director 4 ad-interim (ECG)	Director 5 (ECG)
				Director 2 (ECG from former Environment and Climate Division)		Director 3 (ECG)	Director 4 ad-interim (ECG)	Director 5 (ECG)		
Gender architecture										
1. Gender and social inclusion team with global responsibility:		P5	P5 until Sept.	P5 VACANT	P5 from April	P5	P5	P5 (incumbent was ad interim lead of social inclusion cluster for 30 per cent of time)	P5 (HQ)	P5 (HQ)
a. professional staff*		P4	P4	P4	P4	P4	P4		P4 (HQ)	P4 (Cairo) hired November
			1 JPO	1 JPO	2 JPOs	2 JPOs	1 JPO		1 TPO (HQ, 6 months)	
									P3 (Bhutan/Delhi)	P3 (Delhi)
								P4	P4 Poverty targeting (Abidjan)	P4 Poverty targeting (Abidjan)
								1 JPO	P4 GTM VACANT	
									P3 GTM VACANT	P4 GTM hired August
										P3 GTM hired August

1 TPO (HQ, 7 months)

*Social inclusion (reporting to SI cluster lead):
P3 Monitoring and results specialist SI & nutrition (Nairobi)*

b. long-term consultants			2	3		2	2	3	3	4	1
c. general service staff	1 (50%)	1 (50%)	1 (50%)	1 (50%)	1 (50%)	1 (50%)	1 (50%)	1 (50%)	1 (50%)	1 (50%)	1 (50%)
							1 temporary	1 temporary	1 temporary	1 GTM	
	2012-2014	2015	2016	2017	2018	2019	2020	2021	2022	2023 to-date	
Gender architecture (continued)											
2. Staff with regional responsibility for (gender and) social inclusion	Regional Gender Coordinators			Social inclusion Officers		Social Inclusion Analysts (reporting to Regional technical lead on environment and climate) ³¹⁴					
	NOB (ESA)		NOC (ESA)		NOC (ESA)	NOC (ESA)	NOC (ESA)	NOC (ESA)	NOC (ESA)	NOC (ESA)	NOC (ESA)
	NOB (WCA)		NOC (WCA)		NOC (WCA)	NOC (WCA)	NOC (WCA)	NOC (WCA)	NOC (WCA)	NOC (WCA)	NOC (WCA)
						NOC (LAC)	NOC (LAC)	NOC (LAC)	NOC (LAC)	NOC (LAC)	NOC (LAC)
						NOB (APR)	NOB (APR)	NOB (APR)	NOB (APR)	NOB (APR)	NOB (APR)
						NOB (NEN)	NOB (NEN)	NOB (NEN)	NOB (NEN)	NOB (NEN)	NOB (NEN)
						VACANT	VACANT	VACANT	VACANT	VACANT	VACANT
									P2 (NEN) TPO Rome		
									6months		
									P2 (NEN)		
											P2 (NEN) hired September
3. Gender focal points	17 GFPs and alternates (4 men) in 2013	17 GFPs and alternates (4 men)	17 GFPs and alternates	23 GFPs 11 alternates	23 GFPs 11 alternates	23 GFPs 11 alternates	37 GFPs (20 HQ, 17 hub level)	37 GFPs (20 HQ, 17 hub level)	38 GFPs and alternates (21 HQ, 17 hub level)	350 project GFPs & implementing partners	Data not yet available

³¹⁴ **Staff working on social inclusion and gender in the regions now allocate less time and attention to gender-related matters compared to previous periods.** The two former Regional Gender Coordinator positions in ESA and WCA (2010 - 2018) covering gender, targeting and later youth were replaced by Social Inclusion Analyst positions in each of the five regions covering gender, targeting, youth, nutrition, persons with disabilities and indigenous peoples, where relevant. The intersectional approach to social inclusion is relevant for IFAD loans and grants in contributing to the SDGs and leaving no one behind. However, this focus also translates to Analysts having less time available to focus on gender-related matters alone compared to the previous Regional Gender Coordinators. Similarly, the Analysts cannot provide the same level of contributions to corporate gender demands. Still, interviews suggest that there is scope for more structured communication, updates and information sharing across the gender and social inclusion team based in HQ and gender-related staff in decentralised offices (with global and regional responsibilities).

						300 project GFPs & implementing partners	350 project GFPs & implementing partners		
4. Gender champion - Senior mgmt.	-	-	-	-	AVP PMD				AVP CSD
5. Validated gender and social inclusion experts in roster	-	-	-	-	-	80	100	80	Data not yet available
6. The gender community	60 group	- 228 group	1500	1700	-	2000 + network	-	-	-
- thematic group (IFAD staff & consultants)		1435 network	network	network					
-gender network (in & outside IFAD)									

Source: UNSWAP reports 2012 – 2022; 2016 mid-term review of the policy on gender; interviews.

Table 32
Staff positions in ECG as at January 2023

Analysis of professional staff posts in ECG organigram by teams and clusters, dated January 2023

ECG teams	G, T & PwD + GTM	Nutrition	Youth	IPs	SI	SI Total	Biodiversity	ECC + ASAP + GEF/LDCF/SCCF/AF + GCF+Sahel+IGREENFIN	ECC Total	Front office + SECAP	ECG overall
Global						17		10	12	4	33
P5	1	1	1			3		3	3		6
P4	3	4		1		8	1	3	4	2	14
P3	2		2		1	5		2	2	2	9
P2		1				1	1	2	3		4
Regional						7			23	1	30
P5						0		5	5		4
P4						0		3	3		3
P3			1			1		4	4		5
P2					1	1		1	1		2
NOD						0		1	1		1
NOC			1		4	5		9	9	1	15

Source: ECG organigram January 2023

The social inclusion cluster appears to have significantly fewer human resources at the regional level compared to the environment and climate cluster. However, this can be accounted for by extra positions in the latter on climate finance and managing specific programmes (Joint Sahel Programme, Inclusive green financing initiative)

G,T & PwD + GTM = Gender, targeting & persons with disabilities + gender transformative mechanism facility

IPs = Indigenous Peoples

SI = Social Inclusion

ECC = Environment and climate change

ASAP = Adaptation for Smallholder Agriculture Programme

GEF/LDCF/SCCF/AF = Global Environment Facility / Least developed country fund / Special climate change fund / Adaptation fund

GCF = Green Climate Fund

Sahel = Joint Sahel programme is a response to the challenges of COVID-19, conflicts and climate change

IGREENFIN = Inclusive green financing initiative

GEWE capacity needs conducted by IFAD

Table 33
Gender capacity needs assessments and development plans

<i>Gender-related capacity needs assessment</i>					<i>Gender-related capacity development plan</i>	
When	By	Of	On	By	Consisting of (with examples of trainings held)	
2016	Gender and social inclusion team	Staff Project directors Focal points	GEWE	Gender unit	-	Webinars on gender and targeting e.g. on how to integrate household methodologies into development operations: IFAD's experience, in 2017
					-	Gender toolkits with How to do notes by training e.g. Strengthening the Gender Equality Approach in the Andean Region training in 2016
					-	Targeted/tailored technical backstopping for staff, projects and consultants e.g. gender training for divisions, such as Partnerships & Resource Mobilisation (2016) and Legal (2016) One-day training organized by IFAD Gender and Nutrition Teams for staff and validated consultants in 2016 on how to integrate gender and nutrition-sensitive approaches into IFAD operations; training sessions for individual regional divisions in 2016/2017; training during missions e.g. Georgia, Swaziland, Sudan in 2016/2017 and project start-up missions (2018)
					-	In-country workshops e.g. on Integrating household methodologies in extension, value chains and rural finance in Rwanda in 2017
2019	ECG	Staff	Mainstreaming themes	ECG	-	Upskilling through Operations Academy (2021-2023)
					-	Gender Clinics for staff
					-	Targeted support for staff
					-	On mission / remote technical backstopping and training for regional, country and project staff
2019	HRD/McKinsey	Staff	Human capital and capacity - strategic, operational and technical areas	CDI HRD OSB	-	Dynamic workforce planning mechanism (2021-2024)
					-	Upskilling through Operations Academy (2021-2023)
2023	Gender and social inclusion team	Staff in HQ Staff in decentralised offices Consultants	GEWE Gender transformative programming	Not yet applicable		Not yet applicable

Source: UNSWAP reports 2017 – 2022 (draft); interviews; internal documents on gender capacity needs assessments and development plans

Key gender guidance and tools produced by IFAD during the evaluation period

Table 34
Key docs, guidance notes, publications, etc.

IFAD Policy/Action Plan	Guidance notes/ HTDN	Specific publication on a Gender approach and training	(Independent) Evaluations – self-reporting
2010-2011			<ul style="list-style-type: none"> IOE published the corporate-level evaluation on IFAD's performance on GEWE; IOE included GEWE as a separate evaluation criterion and rate it (2011)
2012 ³¹⁵	<ul style="list-style-type: none"> Policy on Gender Equality and Women's Empowerment (September 2012) 		<ul style="list-style-type: none"> UN-SWAP- self- reporting (from 2012 onwards) IFAD's Report on Development Effectiveness (RIDE) includes an annual report on the IFAD Policy on GEWE (in an annex, from 2012 onwards)
2013			<ul style="list-style-type: none"> Gender began to be tracked systematically by management using the gender markers³¹⁶ Gender began to be tracked more systematically in ARRI
2014	<ul style="list-style-type: none"> Toolkit: Household methodologies: harnessing the family's potential for change: teaser; how to do note; case studies (household mentoring, Uganda; GALS in Ghana, Nigeria, Rwanda, Sierra Leone, Uganda) October 2014 	<ul style="list-style-type: none"> IFAD's Gender and Targeting Webinar Series (PowerPoints available from 2014) A 2014 PowerPoint linked to a <i>short paper on IFAD's gender markers</i> Regional and sub-regional briefs on Gender Equality and Social Inclusion 	
2015	<ul style="list-style-type: none"> GEWE- scaling up note 	<ul style="list-style-type: none"> Ppt on measuring women's empowerment in agriculture: a streamlined approach (from RIA; research and impact assessment department) Promoting the leadership of women in producers' organizations - Lessons from the experiences of FAO and IFAD 	

³¹⁵ **Before the evaluation period (2012-2023)**, IFAD produced other key gender corporate documents, such as a report on Strategies for the Economic Advancement of poor rural women (1992), the 2022-2006 Strategic Framework which considered women as “agents of change” in communities and called for gender to be “mainstreamed” in IFAD’s work, the 2003-2006 Plan of Action for Mainstreaming a Gender perspective in IFAD’s operations (which included key definitions). Also in 2006, IFAD approved the targeting policy, guidelines for project completion reports and for results-based COSOP (with a checklist for inclusion of gender issues in the appendix), and an internal progress review and self-assessment to take stock of experiences promoting GEWE. In 2007, project design guidelines and checklists for gender-sensitive designs were developed (GEWE issues had to be treated under poverty, social development and targeting), along with supervision guidelines. In 2008, IFAD published with FAO and the World Bank the sourcebook on gender and agriculture and with FAO and ILO the report Gender dimensions of agricultural and rural development: differentiated pathways out of poverty. Status, trends and gaps, along with a series of briefing notes and policy briefs on gender; and in 2009 the IFAD policy on indigenous peoples was approved.

³¹⁶ Both in Annual Review of Portfolio Performance and in the Annual Report on IFAD’s Development Effectiveness (RIDE). A separate annex on gender was included in the RIDE until 2020. After 2019, another annex is included with the four mainstreaming themes.

	IFAD Policy/Action Plan	Guidance notes/ how-to-do notes	Specific publication on a Gender approach and training	(Independent) Evaluations – self-reporting
2016	<ul style="list-style-type: none"> • 2016-2025 IFAD Strategic Framework³¹⁷ (overall framework, not gender specifically) • Gender mainstreaming in IFAD10 October 2016 (short-term gender action plan 2016-2018 that did not go to the EB for approval) 	<ul style="list-style-type: none"> • Toolkit: Reducing rural women's domestic workload through labour-saving technologies and practices: teaser, how to do note, lessons learned – reducing women's domestic workload through water investments, compendium of rural women's technologies and innovations (April 2016) 	<ul style="list-style-type: none"> • 4 page brief - Greater focus on having gender transformative projects under IFAD10 • IFAD's Gender and Targeting Webinar Series (PowerPoints available from 2016) • Gender in climate smart agriculture, Module 18 for the Gender in Agriculture Sourcebook July 2016 • Spotlight 5 (GEWE) on the 2016 Rural Development Report 	<ul style="list-style-type: none"> • Mid-term review of IFAD's Gender Policy (August 2016)
2017	<ul style="list-style-type: none"> • Consultation on IFAD 11: mainstreaming of climate, gender, nutrition and youth IFAD (October 2017) • 5R action plan to improve gender parity in IFAD (2017-2021) 	<ul style="list-style-type: none"> • The mandatory outline for COSOPs also includes gender analysis of rural poverty and gender profiling of target groups (as reported in RIDE) • (March 2017) in English, Arabic, French and Spanish <ul style="list-style-type: none"> • Toolkit: Poverty targeting, gender equality and empowerment ³¹⁸, including: (i) teaser, (ii) how-to-do note -HTDN during project design, (ii) HTDN during implementation (June 2017) 	<ul style="list-style-type: none"> • Glossary on gender issues • Grant Results Sheet OXFAM Novib - Community-led value chain development for gender justice and pro-poor wealth creation (February 2017) <ul style="list-style-type: none"> • "Measuring Women's Empowerment in Agriculture: A Streamlined Approach." IFAD Research Series 19. Rome: IFAD December 2017 • The Joint Programme on Accelerating Progress towards the Economic Empowerment of Rural Women (JP RWEE) pathway to women's empowerment April 2017 • DRAFT Paper on gender transformative change (Anita Kelles-Viitanen) <ul style="list-style-type: none"> • Advancing rural women's empowerment (September 2017) • Paper on '<u>Mainstreaming of climate, gender, nutrition and youth</u>' <ul style="list-style-type: none"> • Household methodologies April 2018 • Integrated promotion of gender equality and women's empowerment: economic empowerment, decision-making and workloads April 2018 • Grant Results Sheet: AKF - Mobilizing public private partnerships in support of women-led small business development March 2018 	<ul style="list-style-type: none"> • IOE Evaluation synthesis on GEWE
2018		<ul style="list-style-type: none"> • (in French): Procédure d'élaboration de programmes d'adaptation de l'agriculture paysanne et transformatrice au genre • How to do note: Design of gender transformative smallholder agriculture adaptation programmes, January 2018 		

³¹⁷ It proposes **gender** equality as one of the 5 principles of engagement along with targeting, empowerment, and others.

The Strategy Plan envisages IFAD consolidating its leading position on innovative gender practice by moving beyond mainstreaming and scaling up and achieving real transformative gender impacts.

³¹⁸ <https://www.ifad.org/en/web/knowledge/-/publication/toolkit-poverty-targeting-gender-equality-and-empowerment>

	<i>IFAD Policy/Action Plan (or key report)</i>	<i>Guidance notes/ how-to-do notes</i>	<i>Specific publication on a Gender approach and training</i>	<i>(Independent) Evaluations – self-reporting</i>
2019	<ul style="list-style-type: none"> • IFAD Framework for implementing transformational approaches to mainstreaming themes: environment and climate, gender, nutrition and youth • 2019-2025 Mainstreaming Gender-transformative approaches at IFAD- Action Plan³¹⁹ • IFAD11 Consultation Report which included points / commitments on strengthening implementation of GTAs 	<ul style="list-style-type: none"> • Revised Operational guidelines on targeting • Online IFAD targeting toolkit for COSOPs and projects from design to completion • Gender clinics by regions (ppts available on IFAD's intranet) - Ppt in 2019 outlines distinctions between GTA and GM markers 	<ul style="list-style-type: none"> • Stocktake of the use of household methodologies in IFAD's portfolio June 2019 • Gender-transformative adaptation - From good practice to better policy, CARE (with IFAD contribution) September 2019 • The faces of empowerment - Photo Essay about the beneficiaries of the Joint Programme on Rural Women Economic Empowerment December 2019 • Research Series Issue 44: Gender, rural youth and structural transformation: evidence to inform innovative youth programming December 2019 • Research Series Issue 43: Youth agrifood system employment in developing countries: a gender-differentiated spatial approach December 2019 	
2020		<ul style="list-style-type: none"> • 'How to do note' on gender and pastoralism 	<ul style="list-style-type: none"> • ESA brief on gender and social inclusion • Rural women and girls 25 years after Beijing: critical agents of positive change <ul style="list-style-type: none"> • Outline of The Gender Network July 2020 • GTA for food security, improved nutrition and sustainable agriculture – A compendium of fifteen good practices December 2020 	RIDE annex on Policy on GEWE replaced by an annex on mainstreaming themes
2021	<ul style="list-style-type: none"> • IFAD Strategy on Diversity, Equity and Inclusion 	<ul style="list-style-type: none"> • Detail about gender rating in the Operations manual – project implementation – Annex 1 – Performance Score Descriptors <ul style="list-style-type: none"> • 2021 How to do note: Securing Women's Tenure Rights • Ppt on mainstreaming the four IFAD mainstreaming themes 	<ul style="list-style-type: none"> • Glossary on gender issues (second edition) • Quality Assurance Group (QAG) report on mainstreaming themes and targeting • Joint Programme on Gender Transformative Approaches for Food Security, Improved Nutrition and Sustainable Agriculture Rural women and girls 25 years after Beijing - Critical agents of positive change February 2021 • Making agricultural and climate risk insurance gender inclusive: How to improve access to insurance for rural women October 2021 • Enhancing women's resource rights for improving resilience to climate change November 2021 	<ul style="list-style-type: none"> • IOE Thematic evaluation on climate change Adaptation • JP RWEE: Final Evaluation May 2021

³¹⁹ Gender Action Plan (GAP) developed through a participatory and consultative process ToC for IFAD investment projects, and results framework developed for GEWE linked to Agenda 2030 and IFAD's 3 Strategic Objectives 2016-2025 developed (and included in GAP)

2022	<ul style="list-style-type: none"> • 5R action plan to improve gender parity in IFAD (2022-2026) 	<ul style="list-style-type: none"> • Detail about gender rating in the Operations manual – project design – Annex VII: mainstreaming guidelines for social inclusion themes • How to do note: Integrating the Gender Action Learning System (GALS) in IFAD operations • Guide to formulating gendered social norms indicators in the context of food security and nutrition (ifad.org), July 2022 	<ul style="list-style-type: none"> • The Gender Transformative Mechanism in the context of Climate Adaptation (GTM) Behavioural science recommendations for the design of gender transformative IFAD programmes • Research Series 74: Women’s empowerment, food systems, and nutrition May 2022 • IFAD11 Impact assessment report (use of women’s empowerment indicators) • IFAD and Evaluation Unit of the Green Climate Fund evidence gap map, interventions for women’s empowerment in developing countries • ASAP Technical Series: Gender and Climate Change (ifad.org) November 2022 • Effectiveness of Life Skills Training Interventions for the Empowerment of Women in Developing Countries: A Systematic Review (ifad.org) December 2022 	<ul style="list-style-type: none"> • IOE Evaluation Synthesis Note on Targeting (shared with management in 2022, published in 2023)
2023	<ul style="list-style-type: none"> • IFAD Poverty Targeting Policy 	<ul style="list-style-type: none"> • Ongoing How to do note on GBV³²⁰ 		<p>Report on IFAD’s Mainstreaming Effectiveness (RIME)</p> <ul style="list-style-type: none"> • IOE Evaluation Synthesis Note on Targeting • IFAD new Evaluation manual³²¹

³²⁰ In 2023, the IFAD gender team initiated the development of a **How to do note about how to tackle Gender-based Violence in IFAD operations**. This note emphasises the need for partnerships with other organizations/local actors working on GBV in rural areas, leveraging each entities’ comparative advantage. Interviews with IFAD gender experts revealed that this work was prompted by IFAD’s involvement in the international campaign “16 Days of Activism against GBV against women and girls”³²⁰ and by requests from project teams. This topic was also found to be the second mostly discussed by state members in the Committee on World Food Security.

³²¹ In recent years, the IOE has undertaken concerted efforts to enhance independent evaluations of GEWE criteria. These efforts include: ensuring an emphasis on social justice and intersectionality in the Evaluation manual; internal gender talks on recurring and emerging issues and approaches, such as feminist evaluation, gender transformative evaluation, among others;³²¹ and annual feedback to the division on UNSWAP performance with discussions on how to strengthen the evaluation of GEWE. See <https://ioe.ifad.org/en/gender-talk-series>

Financial resources tracking systems and allocation targets

IFAD has developed systems to monitor core budget resources allocated for supporting gender-related work, but there is room for improvement in these systems.³²² The first tracking system estimates staff time spent on gender-related activities by job families. This is a reasonable proxy for administrative costs spent on gender-related work given that staff costs represent the bulk of the net regular budget. However, they do not account for costs of consultants and staff duty travel (around 40 per cent of costs)³²³ and may have overestimated the real time spent by gender focal points (see above). The second tracking system involves rating ex-ante the gender-sensitivity of each loan programme and grant design using a six-point rating scale.³²⁴ The monetary value of loans and grants rated moderately satisfactory (4) or above and highly satisfactory (6) out of the total loan and grants approved each year. Based on the evidence provided to the evaluation team, the rating scale criteria is not standardised to ensure a consistent approach over time.

There is room for improvement in meeting UNSWAP requirements concerning financial resource tracking for gender-related initiatives. IFAD meets the requirements of the UNSWAP performance indicator on financial resource tracking. To exceed requirements, akin to UNDP, IFAD would need to extend resource tracking across all budgets and make the connections between tracking results and budgeting discussions and processes more explicit (see box below).

Box 29 UNDP financial resource tracking method

The United Nations Development Programme (UNDP) rolled out its gender marker (rating) system in 2009, which scores projects from 0 to 3. The Gender Steering and Implementation Committee (GSIC) reviews the gender marker and results of financial resources tracking. Decisions have been taken using results from the gender marker to influence central strategic planning such as UNDP's Funding Windows allocation of non-emergency resources. The Funding Windows requires all project proposals to be scored 2 or 3 to qualify for funding and are reviewed by gender assessors. The UNDP's project management quality assurance mechanism ensures that gender tagging is accurate.

Source: <https://www.unwomen.org/sites/default/files/Headquarters/Attachments/Sections/How%20We%20Work/UNSystemCoordination/UN-SWAP/UN-SWAP-2-TN-PI09-Financial-resource-tracking-en.pdf>

³²² Given the objectives of the Gender Policy and 2019 Action Plan, the TE interprets “core budget resources” to mean the “administrative budget” and the “programme of loans and grants”, both of which come from replenishment funds. This is also in line with the UNSWAP performance indicator on financial resource tracking.

³²³ IFAD 2017 UNSWAP report refers to discussions in IFAD about introducing a financial benchmark whereby the total number and/or cost of gender specialist consultants hired by PMD to partake in design and supervision work could be tracked and compared across years. This would provide a clearer picture of the level of non-staff costs of gender-related activities. However, no evidence has been found that this has been done.

³²⁴ This is performed by the gender and social inclusion team and involves a detailed assessment of each loan component based on activities and budget information. Ratings are averaged to identify the final rating per loan programme. Note therefore, that this is not the same as the GEWE rating at design from QAG used to report against policy/action plan outcomes.

Figure 28
Staff and non-staff budget

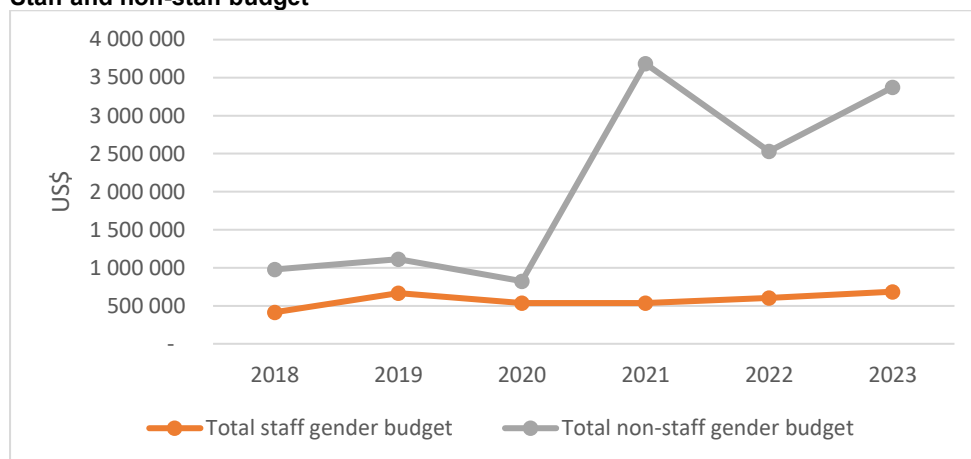

Source: Budget data from gender and social inclusion team; core non-staff budget data in 2018 from 2018 UNSWAP report

Figure 29
Staff time as a proxy of administrative budget on gender-related work

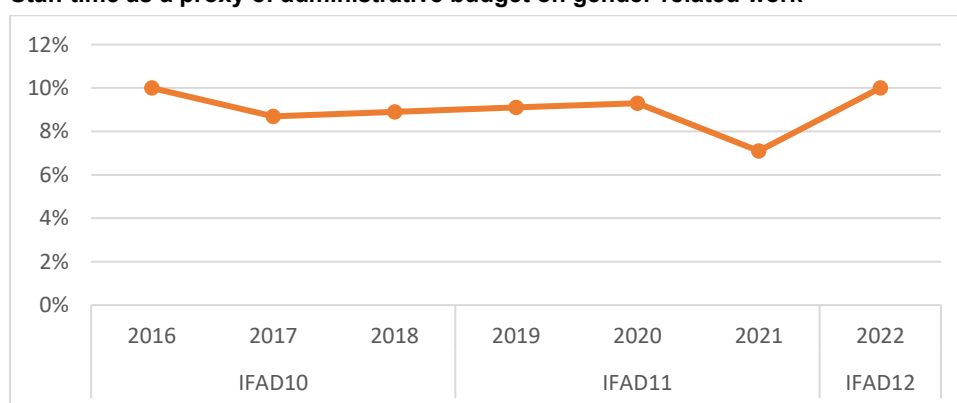

Source: IFAD RIDE and UNSWAP reports, 2013 to 2022

Figure 30
Value of loan programmes rated 4 or more and rated 6 (from gender-sensitivity budget analysis)

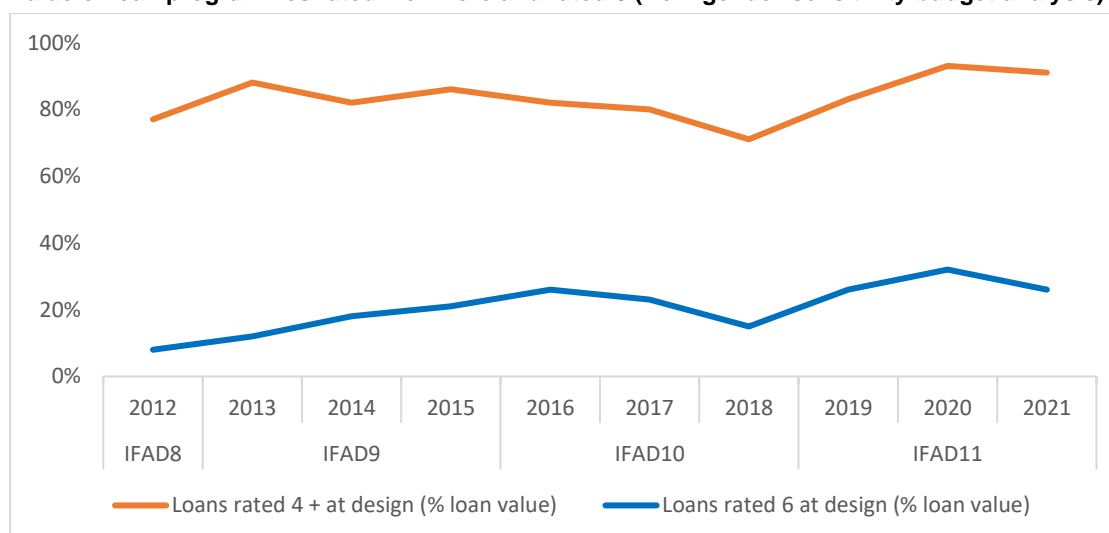

Source: IFAD RIDE reports 2013 – 2022

Figure 31
Percentage of grant projects rated 4 or more and rated 6 (from gender-sensitivity analysis)

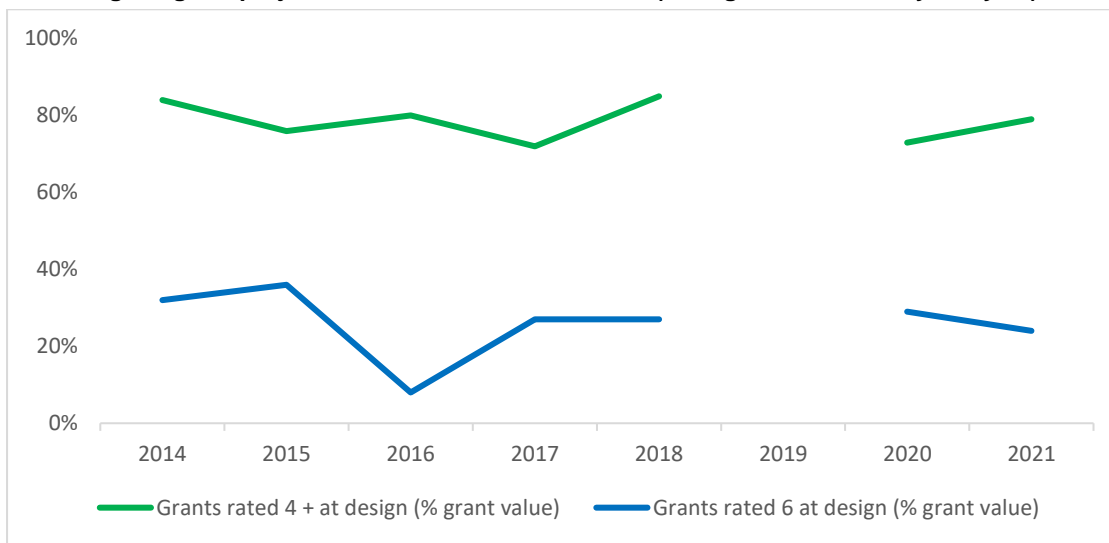

Source: IFAD RIDE reports 2015, 2016, 2017, 2019, 2021, 2022

Figure 32
Value of grant projects rated 4 or more and rated 6 (from gender-sensitivity budget analysis)

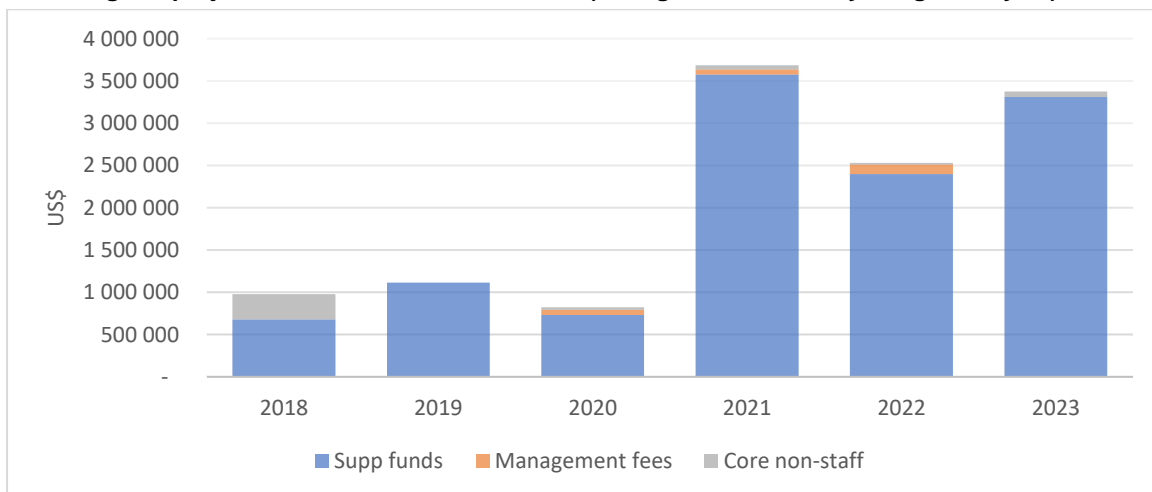

Source: Budget data from gender and social inclusion team; missing data on core non-staff budget taken from IFAD 2018 UNSWAP report

Additional information about self-high-level reporting.**Table 35**
Selected gender-related indicators reported in RIDE

	<i>RIDE 2013</i>	<i>RIDE 2017</i>	<i>RIDE 2021</i>	<i>RIDE and RIME 2023³²⁵</i>
Increase in the proportion of the programme of loans and grants with gender-specific objectives supported by clear budget allocations - Gender sensitivity analysis of (value of) loans (design)	77% of loan value rated moderately satisfactory or above 8% of loan value rated gender transformative (score=6) ³²⁶	82.3% of the value of the loans is rated moderately satisfactory or above 26.4% of loan value rated gender transformative (score=6) ³²⁷	93% of loan value rated moderately satisfactory and above ³²⁸ 32% of loan value classified as gender transformative ³²⁹	89% of loan value rated moderately satisfactory and above (RIME 2023) 30% of loan value rated highly satisfactory (RIME 2023)
% of projects rated 4 +at design (QAG ratings)	96% of projects designed in 2012/ 2013	96.7% of projects approved between 2014 and 2016	95% of project portfolio in 2020	100% of project portfolio in 2022
% of projects rated 4+ at completion (PCR ratings)	91% of projects completed in 2012/ 2013	87% of projects completed between 2014 and 2016	86% of projects completed between 2018 and 2020	89% of projects completed between 2021 and 2023
% of projects rated 5+ at completion (PCR ratings)	NA	54% of projects completed between 2014 and 2016 (target was not yet included in the RMF)	51% of projects completed between 2018 and 2020	42% of projects completed in 2022
Outreach to women by IFAD-supported projects	49%	50%	51%	50%
% of women in P-5 posts or above	28%	25%	34%	44.4%

³²⁵ Some indicators are reported separately in the RIME since 2023.³²⁶ Analysis of the 35 loans, amounting to US\$825 million, that were approved by the Executive Board between September 2012 and April 2013.³²⁷ Analysis of 30 loans approved in 2016, amounting to approximately US\$780 million.³²⁸ Analysis of 27 loans approved in 2020, amounting to US\$ 751,857,465. Out of those, four projects equivalent to US\$ 52,421,523 were not eligible for the analysis because they did not require the development of a new project design document.³²⁹ Equivalent to USD 226 million.

Table 36
Selected indicators reported in IFAD UNSWAP

Indicator	2016	2017	2018	2019	2020	2021
Gender-Responsive Performance Management	IFAD's competency framework was developed through a participatory process with staff and is in place since 2013. Through its Reward and Recognition Framework, IFAD also rewards staff based on the new competency framework that clearly includes gender considerations.					
	The 360-degree feedback continues to be used for managers to promote cultural diversity and gender equality.	IFAD is strengthening its existing learning programme through innovative learning activities aimed at supporting staff growth and development	in 2018 IFAD conducted a series of reassignment exercises for staff.	The Workplace Culture and Staff Engagement Survey 2019, includes questions on gender balance, discrimination, equal treatment and all forms of harassment.	The composition of the Performance Rebuttal Board is gender diverse. HRD's provided IFAD staff with mandatory online trainings on gender equality.	In PES 2021, Competency or behavioural goals will be assessed with the overall weight 40%. IFAD Staff Awards Programme is currently under review
Financial resource allocation	Over the last years, it has become more and more difficult to receive supplementary funds for gender activities. The present gender architecture can barely cope with the new Strategic Framework.	The OBOD requested the PTA to review the gender allocation for each staff position in IFAD to ensure that the data more accurately reflect the gender component of staff time. IFAD addresses gender in its loans with 100% gender mainstreaming	IFAD gender sensitive funding has increased. The decline in funding has coincided with a slow decline in the gender performance of IFAD's portfolio. The present gender architecture has challenges coping with the levels of innovation, scaling-up and learning for IFAD11.	PoLG related target in financial terms have yet to be developed (currently only for Climate).	IFAD revised its methodology for estimating the portion of the staff budget that is dedicated to gender.	PoLG related target in financial terms have yet to be developed (currently only for Climate).
Organizational culture	The Ethics Office conducts mandatory trainings and refresher sessions on ethics and antiharassment for all staff (e-learning was launched in 2015).	A new structured action plan has been prepared as mentioned above through a wide consultation with staff, in order to ensure that actions effectively address main indications received from staff.	IFAD organized a staff training on Masculinities and VBG. An internal awareness raising campaign was held by the Gender Team and Ethics Office to end VBG and SEA. A new structured action plan has been prepared. The GGS was revised and, among other changes, incorporated a more focused gender perspective	A SH/SEA task force was established and drafted the new policy IFAD introduced Teleworking pilot programme to facilitate staff. A new structured action plan has been prepared and implemented in 2019. The 2018 GSS results have continued to reflect positive improvements.	ETH continued to drive corporate efforts on response to SH and SEA. the EMC established the Workplace Culture Task Force (TF). the Task Force received EMC approval on a draft Action Plan.	A dedicated DEI Working Group (WG) was established. The WG devised 'IFAD Strategy on Diversity, Equity and Inclusion' IFAD-wide survey on hate speech, racism and discrimination was conducted.

Table 37
Indicator met or exceeded reported in the UNSWAPs

	2012	2013	2014	2015	2016	2017	2018 (UNSWAP 2.0)	2019	2020	2021	2022
Exceeding requirements	5/15	5/15	7/15	8/15	8/15	9/15	4/17	8/17	8/17	8/17	8/17
Meeting requirements	3/15	5/15	4/15	3/15	3/15	4/15	8/17	6/17	6/17	6/17	6/17
Meeting or exceeding requirements	8/15	10/15	11/15	11/15	11/15	13/15	12/17	14/17	14/17	14/17	14/17
Approaching requirement	6/15	4/15	3/15	4/15	4/15	2/15	5/17	2/17	2/17	2/17	2/17
Missing or not applicable*	1/15	1/15	1/15	0/15	0/15	0/15	0/17	1/17	1/17	1/17	1/17

* In the UNSWAPs 2012, 2013 and 2014, the performance indicator (PI) "Resource Allocation" was missing because there was no "specific allocation of financial resources to gender equality and women's empowerment at the corporate level" and IFAD was yet to "set a financial target for meeting its gender equality objectives". In the UNSWAPs 2019, 2020, 2021 and 2022 the PI3 "Programmatic Gender-Related SDG Results not Directly Captured in the Strategic Plan" was not applicable because IFAD reported on this indicator in PI1 "Strategic Planning Gender-Related SDG Results" and PI2 "Reporting on Gender-Related SDG Results".

** Between 2019 and 2022 there was no change in the status of the 17 performance indicators.

Gender and diversity balance and organizational culture

Table 38
Gender balance of IFAD staff categories 2016 to 2023

Staff position	2016			2017			2018			2019			2020			2021			2022			2023			
	F	M	% F	F	M	% F	F	M	% F	F	M	% F	F	M	% F	F	M	% F	F	M	U	% F	F	M	U
XG1	2	12	14%	6	14	30%	8	19	30%	10	22	31%	11	24	31%	13	23	36%	11	24	31%	0	6	0%	
NOA	2	2	50%	3	1	75%	3	1	75%	8	6	57%	8	6	57%	7	6	54%	4	3	57%	4	3	57%	
NOB	2	3	40%	3	3	50%	3	3	50%	7	3	70%	12	5	71%	9	5	64%	16	16	50%	23	21	52%	
NOC	4	26	13%	9	28	24%	10	28	26%	11	28	28%	15	29	34%	13	28	32%	10	23	30%	15	17	47%	
NOD	2	1	67%	1	1	50%	1	1	50%	1	1	50%							2		100%	2	0	100%	
National Officers	10	32	24%	16	33	33%	17	33	34%	27	38	42%	35	40	47%	29	39	43%	32	42	43%	44	41	52%	
G-1	2	1	67%	1	1	50%																			
G-2	9	8	53%	9	13	41%	9	12	43%	5	11	31%	1	6	14%	2	7	22%	4	6	1	36%	2	18	10%
G-3	21	5	81%	24	6	80%	21	4	84%	28	3	90%	20	8	71%	17	10	63%	17	9	65%	25	17	60%	
G-4	43	13	77%	45	11	80%	41	11	79%	39	12	76%	45	9	83%	39	10	80%	46	10	82%	51	15	77%	
G-5	76	19	80%	74	20	79%	72	17	81%	71	15	83%	66	16	80%	70	16	81%	68	13	84%	77	18	81%	
G-6	55	8	87%	53	8	87%	48	9	84%	41	7	85%	52	9	85%	51	8	86%	48	9	84%	44	9	83%	
G-7	1		100%	1		100%																			
All GS	207	54	79%	207	59	78%	191	53	78%	184	48	79%	184	48	79%	179	51	78%	183	47	1	79%	199	77	72%
P-1	2	2	50%	5	2	71%	2	2	50%	4	1	80%	3	2	60%	1	3	25%	2	4	33%	5	2	71%	
P-2	41	19	68%	37	17	69%	36	18	67%	32	20	62%	45	27	63%	51	21	71%	49	27	64%	46	32	59%	
P-3	49	43	53%	49	45	52%	49	43	53%	47	51	48%	56	52	52%	62	66	48%	60	80	43%	67	88	43%	
P-4	47	45	51%	45	45	50%	43	42	51%	51	44	54%	60	52	54%	65	57	53%	71	59	55%	78	60	57%	
P1 to P4	139	109	56%	136	109	56%	130	105	55%	134	116	54%	164	133	55%	179	147	55%	182	170	0	52%	196	182	52%
P-5	22	62	26%	21	66	24%	24	61	28%	23	57	29%	30	64	32%	30	60	33%	34	59	37%	36	59	38%	
D-1	4	12	25%	5	14	26%	5	14	26%	12	12	50%	10	13	43%	12	11	52%	14	10	58%	14	10	58%	
D-2	1	5	17%	2	4	33%	2	4	33%	2	3	40%	1	1	50%	1	4	20%		2	0%		2	0%	

Ungraded (APR)	2	2	50%	1	2	33%	1	4	20%	1	4	20%	1	4	20%	1	3	25%	3	3	50%	3	4	43%	
Ungraded (V-P)		1	0%		1	0%	1		100%	1		100%				1		0%		1		0%			
Ungraded (PRE)		1	0%		1	0%		1	0%		1	0%		1	0%		1	0%		1	0%		1	0%	
P5 and above	29	83	26%	29	88	25%	33	84	28%	39	77	34%	42	83	34%	44	80	35%	51	76	0	40%	53	76	41%
TOTAL	387	290	57%	394	303	57%	379	294	56%	394	301	57%	436	328	57%	444	340	57%	459	359	1	56%	492	382	56%

Source: Data from HRD

Note: Data each year as of 1 July. Includes all staff employed on a fixed-term, continuous and indefinite contract, as well as short-term staff, service contract holders, JPOs, staff on supplementary funds and special agreements. Staff on Leave & ILC staff are not included.

XG1 = Driver / Administrative Assistant; F = Female; M = Male; U = Other / prefer not to say; APR = Associate Vice-President ; V-P = Vice-President; and PRE = President.

Figure 33
Women’s representation in IFAD by staff categories 2016-2023



Source: Evaluation team analysis of data from HRD

Women’s representation as country programme managers/country directors from 2016 to 2022 by regional division

Figure 34
Women’s representation in APR region

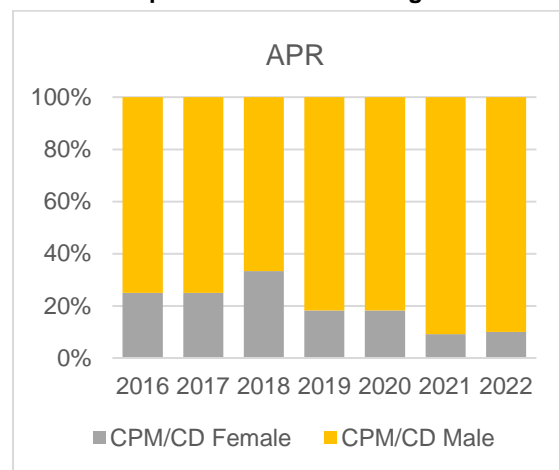

Figure 35
Women’s representation in NEN region

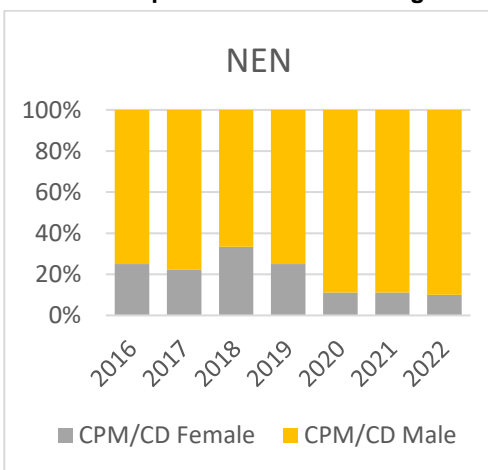

Figure 36
Women’s representation in WCA region

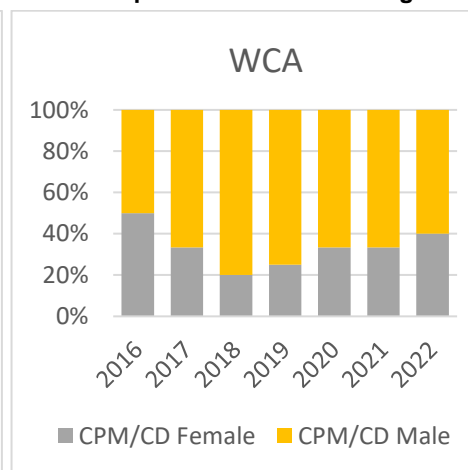

Figure 37
Women’s representation in ESA region

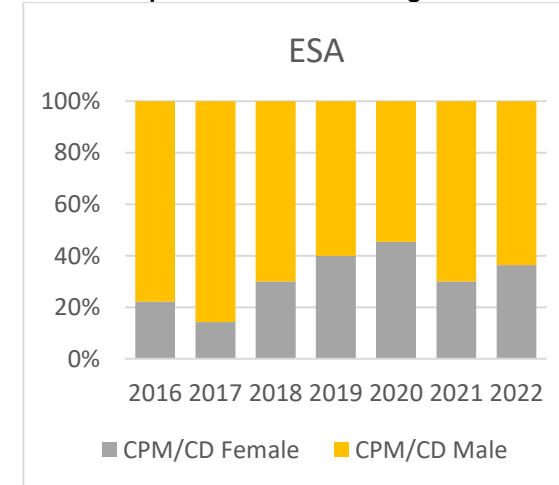

Figure 38
Women’s representation in LAC region

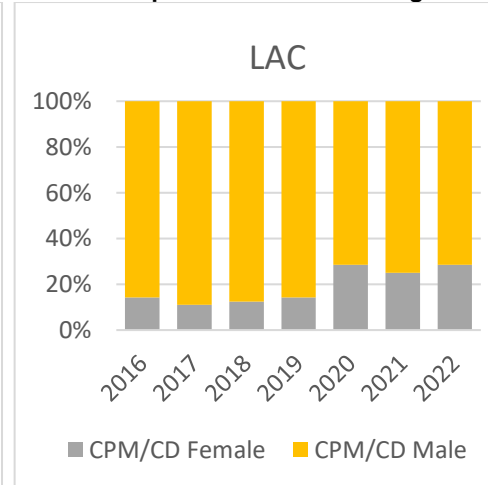

Table 39
Number of Country Directors / Country Programme Managers

	2016	2022
APR	8	10
NEN	8	10
WCA	10	15
ESA	9	11
LAC	7	7

Gender balance among staff – recruitment, retention, reassignment

IFAD has made some initiatives to facilitate a gender-responsive recruitment process, but staff perception in this regard has deteriorated over time. An internal study in 2017 found that gender had an effect on being in a P5 post and on career advancements, all other factors controlled for, and that the more independent the recruitment process, the better for women’s career advancement.³³⁰ Recruitment process guidelines (2022) and Human Resources Implementing Procedures outline a diversity- and gender-responsive approach to recruitment. They mainstream considerations of equitable geographical distribution and gender balance throughout the recruitment process articulating how to do so at each stage (job-opening, longlisting, pre-screening, short-listing and in the interview report to the Appointment and Promotion Board). Specific efforts are made for positions at the P4 level and above. Interview panels also try to ensure members are balanced in terms of gender, geographic distribution and divisional/unit diversity. Critically, interviews indicate that these processes are followed.

Unconscious bias training was provided to 43 staff involved in interview panels in 2018 and 2019, with the aim of minimising implicit bias. Interviewees found bias training a useful exercise with perceived reductions of gender bias in interview panels. Training on unconscious bias is now integrated into mandatory training on gender and DEI. Whether this one-off training is sufficient, will need to be assessed in due course. Additional activities by IFAD to increase visibility of hard-to-fill positions include the use of online job boards (for example, Impactpool) and virtual career fairs, including those tailored solely to women and senior women professionals.³³¹ This was confirmed in interviews. However, limited resources mean that efforts are inconsistent, for example in 2023 IFAD has not subscribed to specialist career fairs.

Despite these initiatives, global staff survey results show that the percentage of both men and women who disagreed with the perception that recruitment at IFAD is rigorous and fair increased from approximately 30 to 40 per cent between 2016 and 2022.³³²

While formal efforts have been made to support the career development of men and women, this sentiment is not reflected among many respondents to the global staff surveys. In past Management Development Programmes and Leadership Development Programmes, HRD tried to ensure an equal number of male and female participants and had coaching sessions to provide leadership-related gender guidance/support to the female participants.³³³ Recent mentoring programmes through the UN and IFAD’s operational academy have seen more women participating than men.³³⁴ However, analysis of staff survey results also shows the proportion of men and women that *disagreed* that they have adequate opportunities to advance their career in IFAD increased from 2016 to 2022 (from 32 to 39 per cent for men and from 37 to 46 per cent for women).³³⁵ Furthermore, the 30 per cent of men and 21 per cent of women that *agreed* with the statement in 2022 was markedly lower than the external benchmark of 51 per cent.

³³⁰ Internal document. Analysing the representation of women among IFAD senior staff; a development effectiveness study by RIA in cooperation with Corporate Services Department, 2017

³³¹ UNSWAP 2017 and 2021

³³² Agreements with the statement decreased for men (from 40% in 2016 to 33% in 2022) and remained the same for women (26% in 2016 and 28% in 2022). The proportion of women that answered neutrally decreased from 45% to 30% over the same time period, which translated into more disagreements to the statement.

³³³ Management development programme (P4, P5), 2018; Leadership development programme for Directors, 2018; Senior Leadership development programme, 2018; Leadership for excellence, 2020; Leadership development programmes today include targeting staff who are not yet supervisors to help develop skills and competencies for career development; Individual interview coaching for shortlisted internal candidates; Training and coaching for Resident Coordinator assessment; Performance management training and coaching to help new/inexperienced supervisors in managing the performance of their supervisees.

³³⁴ UN Together Mentoring has 37 participants (68 per cent); OPAC mentorship programme in 2022 had 41 participants (59 per cent) and in 2023 21 participants (57 per cent). Data from HRD

³³⁵ Agreements with the statement decreased for men (from 40% in 2016 to 33% in 2022) and remained the same for women (26% in 2016 and 28% in 2022). The proportion of women that answered neutrally decreased from 45% to 30% over the same time period, which translated into more disagreements to the statement.

IFAD’s reassignment processes for professional staff have resulted in greater grade mobility for men compared to women. Between 2018 and 2022 there were five reassignment exercises for professional staff, see table below. In total, 36 men in professional posts have been reassigned to a higher grade compared to 26 women. However, six out of the eight staff assigned to a lower professional grade were also men. Analysis of staff survey results (2016-2022) shows that a consistently low proportion of staff (17 to 20 per cent) agree that mobility opportunities are applied in an equal and transparent manner to all staff (with similar answers from men and women).

Table 40
Changes to men’s and women’s grades from reassignment exercises

Year	2018 – 2019				2000		2022			
	Exercise name	Wave 1	Wave 2	Fit-for-purpose	Reassignment /mobility framework	Reassignment /mobility framework				
	F	M	F	M	F	M	F	M		
Total	3	6	2	9	8	3	7	6	6	12

Source: Statistics from HRD

Limited statistics were obtained from HRD on staff retention rates from 2020 to September 2023. They are inconclusive with rates remaining above 92 per cent for female and male staff overall and in the professional and general service categories. Similarly, the results of gender related questions in exit interviews could not be obtained because they reportedly commenced in 2022.

Organizational culture – flexible working arrangements

Since the COVID-19 crisis, IFAD has augmented its flexible working arrangements. The COVID-19 crisis meant staff had to work remotely for most of 2020, leading to the widespread uptake of teleworking arrangements. They were formerly piloted in 2021/2022, surveyed in 2021, with new provisions established regarding flexible working arrangements in April 2023. Interviews showed that men and women staff were widely appreciative of the ability to telework in their duty station up to 3 days a week, affording them greater flexibility to manage personal, family and professional commitments.³³⁶ This is in line with the headline survey results in box VI.12, which show the benefits of teleworking as well as different preferences for arrangements between men and women and the persistent problem of heavy workloads. The results also demonstrate that flexible working is a gender issue – women generally prefer more days teleworking and fewer days in the office compared to men.³³⁷

Box 30

Headline results of IFAD 2021 survey of teleworking arrangements

Teleworking survey results show 80 per cent of staff found the teleworking experience positive and 70 per cent reported being more productive than “usual” (solely working in the office pre-pandemic). The downside was that 73 per cent of staff reported an increased workload as a result of the teleworking modality (and increased meetings and calls) as well as the COVID-19 emergency response. Staff preferences of where to work from varied: 40 per cent at the duty station, 24 per cent in the country of the duty station; 20 per cent out of the country of the duty station. When asked how many days per week they would prefer to telework, women showed a preference for more days teleworking compared to men.

Source: IFAD 2021 Teleworking arrangements survey results. Out of 691 answers, 159 were from decentralised offices and 532 from HQ, while 422 were from women and 269 from men.

³³⁶ Teleworking in the duty station refers to being within commuting distance (defined as 150 km or 1.5 hours, whichever is less, from the IFAD HQ/Office. In addition, there is an exceptional teleworking provision that allows requests of up to 10 consecutive working days once in a month, subject to an overall ceiling of 35 cumulative working days per year.

³³⁷ Research into American women’s century long journey towards equity by Claudia Goldin, Nobel Laureate, identified how the growth of remote and flexible work may be the pandemic’s silver lining (for women’s advancement at work), particularly in “greedy” professions that demand long hours and weekend work.

Unified parental leave provisions were introduced in 2023, replacing and significantly improving upon the previous maternity, paternity and adoption leave rules for staff on fixed-term or indefinite appointments.³³⁸ Previously mothers had up to 24 weeks, fathers up to 8 weeks (plus four weeks if working in non-family duty station), an adopting parent up to 8 weeks, and a surrogate parent no leave. The new unified provisions now acknowledge the important role of each caregiver in raising a child by granting 16 weeks to all parents (birth, non-birth, adopting, and surrogate) with full pay and an additional 10 weeks for birth parents with full pay to meet specific pre-delivery and post-delivery needs.³³⁹ The birth parent therefore has a total of 26 weeks (or 6 months) of parental leave in line with the WHO's recommendation for breastfeeding/bonding with a child and what is considered good practice in the UN.³⁴⁰ The evaluation learnt that some parents also make use of the HR provision "special leave without pay" to extend their total leave as well as the additional provision for breastfeeding.

In theory, unified parental leave contributes to improved gender equality at home and work as well as to early childhood development. This will only happen if both parents, and all types of parents, take up the offer of leave. It will be important to monitor whether this occurs. There is also scope to provide additional leave to parents who have multiple births (for example, twins)³⁴¹ or whose babies require neonatal care.³⁴²

IFAD had an onsite childcare facility at headquarters until the pandemic, since then, staff have been informed about alternative arrangements. Before the COVID-19 pandemic, the onsite childcare facility in headquarters was a valuable resource for working parents (staff and long-term consultants) with young children. It also included a nursing room for parents to feed their babies. Since its closure in 2020 during the lockdown in Rome it has not reopened due to insufficient demand from IFAD staff in subsequent school years. This can be explained by the widespread use of teleworking and parents' use of childcare facilities closer to their homes. During the pandemic, IFAD informed interested parents of alternative arrangements.³⁴³

IFAD is currently in the process of formally changing procedures to provide support for staff with dependents with disabilities. As noted by UN Women (2021), paternal leave, childcare facilities and breastfeeding policies often fall short when staff are required to care for ageing parents, children with special needs, or a family member with a disability. This also emerged as an issue during TE interviews. Updates to HR implementing procedures to ensure there are measures to support staff with dependents with disabilities and also factor this into IFAD's mobility policy are a positive step, in line with UN good practice.³⁴⁴

³³⁸ HRD information circular 21 March 2023, entered into effect retroactively as of 1 January 2023.

³³⁹ Unified parental leave is more inclusive by advocating for gender-neutral parental leave, moving away from the concept of primary and secondary caregiver, to only differentiate between birth and non-birth parents

³⁴⁰ UN Women, UNAIDS, UNICEF, UNHCR, UNFPA, WHO, WFP, UNESCO and FAO have extended *maternity* leave to 24 weeks. UN Women, UNICEF and UNAIDS provide 16 weeks of *paternity* leave.

³⁴¹ UN Women, 2021, *Make Parity a Reality*; Field-specific Enabling Environment Guidelines for the UN system. IOM provides four additional weeks to all parents in case of multiple births.

³⁴² Example good practice: UK Neonatal Care (leave and pay) Act 2023

³⁴³ For example, the availability of FAO childcare and WFP childcare for IFAD staff and/or other Rome-based childcare with discounts for IFAD staff

³⁴⁴ UN Women, 2021, *Make Parity a Reality*; Field-specific Enabling Environment Guidelines for the UN system.

Bibliography consulted

IFAD documents (selected)

- IFAD. 2012. Gender equality and women’s empowerment policy.
- IFAD. 2014 (a). How to do household methodologies.
- [IFAD. 2014](#) (b). Case study Gender Action Learning System in Ghana, Nigeria, Rwanda, Sierra Leone and Uganda.
- [IFAD. 2014](#) (c). Case study Household Mentoring, Uganda.
- [IFAD. 2014](#) (d). Case study Transformative Household Methodology, Ethiopia.
- [IFAD. 2014](#) (e). Case study Household Approach, Zambia.
- [IFAD. 2014](#) (f). Case study Household Approach for Gender, HIV and AIDS Mainstreaming, Malawi.
- [IFAD. 2015](#). Promoting the leadership of women in producers’ organizations: Lessons from the experiences of FAO and IFAD.
- IFAD. 2016 (a). Midterm Review of IFAD’s Policy on Gender Equality and Women’s Empowerment. EB 2016/118/R.9
- IFAD. 2016 (b). Gender mainstreaming in IFAD10.
- [IFAD. 2016](#) (c). IFAD Strategic Framework 2016- 2025: Enabling inclusive and sustainable rural transformation.
- [IFAD. 2016](#) (d). Lessons learned Reducing women’s domestic workload through water investments.
- [IFAD. 2016](#) (e). How to do Reducing rural women’s domestic workload through labour-saving technologies and Practices.
- [IFAD. 2017](#) (a). Glossary on Gender Issues.
- [IFAD. 2017](#) (b). Toolkit: Poverty Targeting, Gender Equality and Empowerment.
- IFAD. 2018. How to design gender transformative smallholder agriculture adaptation programmes.
- IFAD. 2018. Report of the Consultation on the Eleventh Replenishment of IFAD's Resources. GC 41/L.3/Rev.1
- IFAD. 2019 (a). Mainstreaming Gender-transformative Approaches at IFAD – Action Plan 2019-2025. EB 2019/126/INF.6
- IFAD. 2019 (b). Stocktake of the use of household methodologies in IFAD’s portfolio.
- IFAD. 2019 (c). Framework for Implementing Transformational Approaches to Mainstreaming Themes: Environment and Climate, Gender, Nutrition and Youth. EB 2019/128/R.6.
- IFAD. 2019 (d). Mainstreaming Gender-Transformative Approaches at IFAD-Action Plan 2019-2025. EB 2019/126/INF.6.
- [IFAD. 2019](#) (e). Revised Operational Guidelines on Targeting. EB 2019/127/R.6/Rev.1
- [IFAD. 2019](#) (f). IFAD Rural Youth Action Plan 2019-2021. EB 2018/125/R.11.
- [IFAD. 2019](#) (g). Mainstreaming nutrition in IFAD Action Plan 2019-2025.
- IFAD. 2020 (a). How to do Gender and pastoralism.
- IFAD. 2020 (b). Rural Resilience Programme. EB 2020/131 (R). INF.4.
- [IFAD. 2020](#) (c). IFAD at the Midterm of the Eleventh Replenishment. IFAD12/1/R.2.
- [IFAD. 2021](#) (d). Glossary on Gender Issues. Second edition.
- IFAD. 2021 (e). IFAD Strategy on Diversity, Equity and Inclusion. EB 2021/134/R.9
- [IFAD. 2021](#) (f). Recomendaciones de las Ciencias del Comportamiento para el Diseño de Programas de Género transformadores.

- [IFAD](#). 2022 (a). How to integrate the Gender Action Learning System (GALS) in IFAD operations.
- IFAD. 2022 (b). Assessing the outcomes of GALS (Gender Action Learning System) in the Joint programme “Rural Women Economic Empowerment” of Rwanda.
- IFAD. 2022 (c). IFAD’s 2022 results-based programme of work and regular and capital budgets, the IOE results-based work programme and budget for 2022 and indicative plan for 2023-2024, and the HIPC and PBAS progress reports. GC /45/L.4
- IFAD. 2022 (d). IFAD Strategy on Diversity, Equity and Inclusion: Annual Report. EB 2022/135/R.21.
- [IFAD. 2022](#) (e). Effectiveness of life skills training interventions for the empowerment of women in developing countries. A systematic review.
- [IFAD. 2022](#) (f). Gender and climate change. ASAP technical series.
- IFAD. 2022 (g). IFAD’s Disability Inclusion Strategy 2022-2027. EB 2022/137/R.7.
- [IFAD. 2022](#) (h). IFAD Policy on Engagement with Indigenous Peoples: 2022 update. EB 2022/137/R.6.
- IFAD. 2023 (a). Report on IFAD’s Mainstreaming Effectiveness (RIME) 2023. EC 2023/122/W.P.5
- IFAD. 2023 (b). IFAD & MAVIM’s - Gender Transformative Mechanism in the context of Climate Adaptation (GTM) for Nav Tejaswini Program, Maharashtra, India.
- [IFAD. 2023](#) (c). IFAD Poverty Targeting Policy 2023. EB 2023/138/R.3.
https://www.ifad.org/documents/38711624/47758862/targeting-policy-2023_e.pdf/edaae22c-efd7-3a72-8c31-fe901e9b9797?t=1689600635635

Grants and JP-related documents

- Centre for International Forestry Research in collaboration with the World Agroforestry Centre, 2019
- CIFOR, 2022, Project Progress Report, Global initiative to secure women’s land rights through gender transformative approaches
- FAO, IFAD, WFP, EU. 2018. Narrative progress Report, Joint Programme on Taking gender transformative approaches (GTAs) to scale for impact on SDG2 to end hunger, achieve food security and improved nutrition and promote sustainable agriculture.
- [FAO, IFAD, WFP, Internal Mid-term Review, 2022, EU-RBA Joint Programme on Gender Transformative Approaches for Food Security and Nutrition and Sustainable Agriculture \(JP GTA\):](#)
- Fundación Capital, 2020, Informe Final, Mujeres – Inclusión Financiera Para Mujeres Jóvenes Rurales
- Gates Foundation, 2023, Progress report, Investment document – Grant
- Hivos – Oxfam, 2022, Annual Report 2021 – 2022, Empower@scale
- IFAD – ILO, 2018, Project Completion Report, Taqueem Initiative, Strengthening gender monitoring and evaluation in rural employment in NEN
- [IFAD JP - GTA 2023 Work Plan Malawi:](#)
- [IFAD JP - GTA 2023 Work Plan, Plan de trabajo conjunto y FAO 2023](#)
- IFAD, 2017, Grant Status report, Mobilizing Public-Private Partnerships in Support of Women-led Small Business Development
- IFAD, 2019, Grant Concept Note, Melanesia Rural Market & Innovation Driven Programme (MERMAID)
- IFAD, 2021, Baseline Report, The Nav Tejaswini Programme by Mahila Arthik Vikas Mahamandal (MAVIM), 2021

- IFAD, 2022, Grant Completion Report, Assessing the Gendered Impact of Rural Development Projects
- IFAD, 2022, Project Progress report 2018 - 2022, Empower@scale
- IFAD, Annual Progress Report, Melanesian Rural Market and Innovation-Driven Development Programme (MERMAID), – Year II 1 October 2021 – 30 September 2022
- IFAD, n.d., Project Completion report, Mobilizing Public-Private Partnerships in Support of Women-led Small Business Development
- ILRI, Solidaridad Southern Africa (Solidaridad), and Global Roundtable for Sustainable Beef (GRSB), 2022 Annual Report, Inclusive Red Meat Value Chains for Women and Youth in Eastern and Southern Africa
- ONU Mujeres, 2017, Informe Final del Proyecto, Mujeres Emprendedoras
- Oxfam Novib, 2022, Project Progress Report, Empower@Scale. Scaling Up Empowerment Through Household Methodologies: From Thousands To Millions
- Oxfam, 2018, Grant Completion Report, Integrating Household Methodologies (HHM) in agricultural extension, value chains and rural finance in Sub-Saharan Africa,
- PARS Research, 2022, Final Evaluation of Empower@Scale Project
Final Report, Strengthening smallholder food security, income and gender equity within West Africa's forest-farm interface.
- IFAD. 2019 (h). Proposal to scale up GALS in the JP RWEE – 2019 (Phase II).
- IFAD. 2021 (a). Proposal to Accept Supplementary Funds from the Bill & Melinda Gates Foundation for the Gender-Transformative Mechanism Initiative.

Independent Office of Evaluation reports (selected)

- IFAD. 2010. Corporate-level Evaluation of IFAD's Performance with regard to Gender Equality and Women's Empowerment. EB 2010/101/R.9.
- IFAD. 2017. What works for gender equality and women's empowerment - a review of practices and results. Evaluation synthesis. Report No. 4390.
- IFAD. 2022 (a). Corporate level evaluation on decentralisation.
- IFAD. 2022 (b). IFAD Evaluation Manual. IFAD. <https://ioe.ifad.org/en/w/evaluation-manual-third-edition>.
- IFAD. 2022 (c). Thematic evaluation of IFAD's Support for Smallholder Farmers' Adaptation to Climate Change. EC 2021/115/W.P.3/Rev.

Other donors

- FAO, IFAD and WFP. 2020 (a). Gender transformative approaches for food security, improved nutrition and sustainable agriculture – A compendium of fifteen good practices.
- [FAO, IFAD and WFP. 2020 \(b\). Rural women and girls 25 years after Beijing: critical agents of positive change. Rome, FAO](#)
- [FAO, IFAD, WFP, 2022, Guide to formulating gendered social norms indicators in the context of food security and nutrition](#)
- FAO and WFP. 2022. The impact of COVID-19 on gender equality and food security in the Arab region with a focus on the Sudan and Iraq. Rome Available here
- [FAO, IFAD, WFP & CGIAR GENDER Impact Platform. 2023. Guidelines for measuring gender transformative change in the context of food security, nutrition and sustainable agriculture. Rome, FAO, IFAD, WFP and CGIAR.](#)
- [FAO, IFAD, UNICEF, WFP and WHO. 2023. The State of Food Security and Nutrition in the World 2023. Urbanization, agrifood systems transformation and healthy diets across the rural-urban continuum. Rome, FAO](#)

Other partners/donors

- [Adaptation Fund. 2022. Study on intersectional approaches to gender mainstreaming in adaptation-relevant interventions.](#)
- [AfDB. 2020. Evaluation Synthesis of Gender Mainstreaming,](#)
- [CARE. 2019. Gender Transformative Adaptation From Good Practice to Better Policy.](#)
- CIFOR and CGIAR. 2015. Gender and climate change: Evidence and experience.
- [CIFOR. 2022. Securing Land Tenure for Women and Girls to Promote Climate Change Resilience. Forest](#)
- [FAO. 2011 \(a\). Evaluation of FAO’s role and work related to Gender and Development \(GAD\)](#)
- FAO. 2011 (b). The State of Food and Agriculture 2010–11. In: Women in agriculture: closing the gender gap for development. Rome.
- [FAO. 2021. FAO Statistical Yearbook 2021. Rome: FAO.](#)
- [Global Environment Facilities. 2017. Evaluation on gender mainstreaming.](#)
- GAMEChange Network. [BALI](#), IFAD.
- International Labour Office (ILO). 2012. A manual for gender audit facilitators; the ILO Participatory Gender Audit methodology, second edition
- [JICA. 2000. Thematic Evaluation, Women in Development \(WID\)/Gender.](#)
- Multilateral Organization Performance Assessment Network (MOPAN) (2024), MOPAN Assessment Report: International Fund for Agricultural Development (IFAD), Paris. [Main report](#) and [Technical Annex](#).
- Oxfam Novib. 2014. Gender action learning system. Practical guide for transforming gender and unequal power relations in value chains.
- Swedish International Agricultural Network Initiative (SIANI). 2013. Transforming Gender Relations in Agriculture in Sub-Saharan Africa.
- UNDP, 2020. Working Paper Gender inequality and the COVID-19 crisis: A Human Development perspective. Available here
- UN Women. 2015. Let’s Dive into Gender Terms: Guide to Terminology and Use of Non-Sexist Language for Journalists, Communicators and Communicators. New York.
- [UN Women. 2020. Work with men and boys for gender equality: a review of field formation, the evidence base and future directions. Discussion Paper for Progress of the world’s women 2019-2020: families in a changing world. Alan Greig and Michael Flood.](#)
- UN Women. 2021 (a). Women in Politics: 2021. New York: UN Women.
- UN Women. 2021 (b). Make Parity a Reality; Field-specific Enabling Environment Guidelines for the UN system.
- [UN Women. 2021 \(c\). Political Empowerment of Women: Framework for Strategic action.](#)
f
- [UN Women. 2021 \(d\). Facts and Figures: Women's leadership and political participation.](#)
- [UN Women. 2022 \(a\). UNSWAP 2.0 Framework and technical guidance.](#)
- [UN Women. 2022 \(b\). Intersectionality Resource Guide and Toolkit, UNPRPD.](#)
- [UN Women. 2022 \(c\). Handbook on Gender Mainstreaming for Gender Equality Results. New York: UN Women](#)
- [UNDP IEO. 2015. Evaluation of UNDP’s contribution to gender equality and women’s empowerment.](#)

[UNFPA, UNICEF. 2020. Technical note on gender-transformative approaches in the global programme to end child marriage phase ii: a summary for practitioners.](#)

[UNICEF. 2020. A New Era for Girls: Taking Stock of 25 Years of Progress.](#)

UNICEF. N.D. Redesigning the workplace to be family-friendly: what governments and businesses can do. <https://www.unicef.org/early-childhood-development/family-friendly-policies>

USAID. 1988. Mission-wide evaluation of women in development.

[USAID. 2014. Women’s Empowerment in Agriculture Study.](#)

[USAID. 2019. Gender Analysis and Assessment Final Report.](#)

[World Bank. 2019. Women, Business and the Law 2019: A Decade of Reform.](#)

[World Bank. 2021. Measuring Women’s Goal Setting and Decision-Making \(English\). Gender Innovation Lab Washington, D.C.: World Bank Group.](#)

World Bank, 2022. The Poverty Podcast: Gender and COVID-19. Available here

[World Bank, 2023. Accelerate gender equality for a sustainable, resilient and inclusive future. Gender Strategy 2024-2030.](#)

General literature and other documents

[Dolislager, M., Reardon, T., Arslan, A., Fox, L., Liverpool-Tasie, S., Sauer, C., and Tschirley, D. 2019. Youth agrifood system employment in developing countries: a gender-differentiated spatial approach. IFAD research Series 43. Rome: IFAD](#)

[Doss, C., Heckert, M., Myers, E., Pereira, A., and Quisumbing, A. 2019. Gender, rural youth and structural transformation: evidence to inform innovative youth programming. IFAD Research Series 44. Rome: IFAD.](#)

[Quisumbing, A., Heckert, J., Faas, S., Ramani, G., Raghunathan, K., Malapit, H., and The pro-WEAI for Market Inclusion Study Team. 2022 “Women’s empowerment, food systems, and nutrition” IFAD Research Series 74. Rome: IFAD.](#)

Mayoux L. and IFAD. 2020. Gender Action Learning System Implementation Toolkit.

[Salzburg Global Seminar and IFAD. 2012. Transforming agricultural development and production in Africa.](#)

Aguilar L. 2021. La igualdad de género ante el cambio climático: ¿qué pueden hacer los mecanismos para el adelanto de las mujeres de América Latina y el Caribe?. serie Asuntos de Género. no 159. CEPAL. Santiago.

Alber G. 2009. Gender and Climate Change Policy. In: Population Dynamics and Climate Change, pp 149-163. UNFPA. New York.

Alinovi L., Hemrich G and Russo L. 2008. Beyond relief: food security in protracted crises. <https://www.fao.org/agrifood-economics/publications/detail/en/c/122132/>

[Alkire, Sabina, Ruth Meinzen-Dick, Amber Peterman, Agnes R. Quisumbing, Greg Seymour, and Ana Vaz. 2012. The Women’s Empowerment in Agriculture Index. Washington D.C.](#)

Archer J. 1984. Gender roles as developmental pathways. British journal of social psychology 23, no. 3: 245-256.

Batliwala S and Pittman A. 2010. Capturing change in women’s realities: A critical overview of current monitoring and evaluation frameworks.

Baylina M., Rodo-Zarate M. 2020. Youth, activism and new rurality: A feminist approach. Journal of Rural Studies, vol. 79. pp. 189-196.

Beneria L. & Sen G. 1981. “Accumulation, reproduction, and” women's role in economic development”: Boserup revisited.” Signs: Journal of women in culture and society 7, no. 2 (1981): 279-298.

Betancor V. 2011. Empoderamiento: ¿Una alternativa emancipadora?. In: Reflexiones para una aproximación crítica a la noción de empoderamiento, pp. 20-31.

- Bilfield, Alissa, David Seal, and Donald Rose. 2020. Brewing a more balanced cup: supply chain perspectives on gender transformative change within the coffee value chain. *International Journal on Food System Dynamics* 11, no. 1: 26-38.
- Blackstone, A. M. 2003. Gender roles and society.
- Bove E. 2016. Three things I learned at the 13th AWID Forum. <https://www.awid.org/news-and-analysis/three-things-i-learned-the13th-awid-forum>
- Bravo-Baumann H. 2000. Capitalisation of experiences on the contribution of livestock projects to gender issues.
- Brown, A. M. 2007. WID and GAD in Dar es Salaam, Tanzania: Reappraising gender planning approaches in theory and practice. *Journal of Women, Politics & Policy*, 28(2), 57-83.
- [Brulé, R., & Gaikwad, N. 2021. Culture, capital, and the political economy gender gap: evidence from Meghalaya's matrilineal tribes. *The journal of politics*, 83\(3\), 834-850. Published online May 17, 2021.](#)
- Cairns Maryann R, Cassandra Workman and Indrakshi Tandon. 2017. Gender mainstreaming and water development projects: analyzing unexpected enviro-social impacts in Bolivia, India, and Lesotho. *Gender, Place & Culture* 24, no. 3: 325-342.
- Canadian Audit and Accountability Foundation (CAAF). 2016. Practice Guide to Auditing Gender Equality.
- Carrasco, C. 2016. Sustainability Of Life And Patriarchal Blindness. A Necessary Reflection. *ATLÁNTICAS. Revista Internacional de Estudios Feministas*. vol 1 no 1. pp. 34-57. <http://dx.doi.org/10.17979/arief.2016.1.1.1435>
- Castillo A., Ordoñez D., Erazo L., and Cabrera J. 2020. Emprendimiento Rural, una Aproximación desde el Empoderamiento Femenino. *Revista Empresarial* 14, 39-51.
- [CEDAW. 2004. General recommendation No. 25, on article 4, paragraph 1, of the Convention on the Elimination of All Forms of Discrimination against Women, on temporary special measures.](#)
- Chauhan K. 2014. Gender and Development. In: *Gender Inequality in the Public Sector in Pakistan*, (Palgrave Macmillan, 2014):13-39.
- Cole S. et al. 2015. Gender-transformative approaches to address inequalities in food, nutrition and economic outcomes in aquatic agricultural systems.
- Cole, S.M., Alexander M. Kaminski, Cynthia McDougall, Alexander S. Kefi, Pamela A. Marinda, Modern Maliko and Johans Mtonga. 2020. Gender accommodative versus transformative approaches: a comparative assessment within a post-harvest fish loss reduction intervention. *Gender, Technology and Development*. DOI: 10.1080/09718524.2020.1729480.
- Constantin A. & Voicu M. 2015. Attitudes towards gender roles in cross-cultural surveys: Content validity and cross-cultural measurement invariance. *Social Indicators Research* 123, no. 3: 733-751.
- Cornwall A. 2016. Women's empowerment: What Works?. *Journal of International Development*, no. 28, pp. 342-359.
- Cornwall, A. & Rivas, A.M. 2015. From 'gender equality and 'women's empowerment to global justice: reclaiming a transformative agenda for gender and development. *Third World Quarterly* 36, no. 2: 396-415.
- Cruşmac, Oana. 2015. Why gender mainstreaming is not enough? A critique to Sylvia Walby's the future of feminism. *Romanian Journal of Society and Politics* 10, no. 1: 102-117.
- Cruz, F., 2012. Perspectiva de género en el desarrollo rural: empoderamiento de las mujeres. In: *Perspectiva de género en el desarrollo rural, programas y experiencias*, pp. 11-40.

- Das, I. 2013. Status of women: North Eastern region of India versus India. *International journal of scientific and research publications*, 3(1), 1-8.
- Davids T., Van Driel F. & Parren F. 2014. Feminist change revisited: Gender mainstreaming as slow revolution. *Journal of International Development* 26, no. 3: 396-408.
- Daynard, A. 2015. Determinants of female entrepreneurship in India. OECD.
- Donna R. Podems. 2010. Feminist Evaluation and Gender Approaches: There's a Difference? ICF Macro Crest, Stellenbosch University, *Journal of MultiDisciplinary Evaluation*, Volume 6, Number 14 ISSN 1556-8180 August 2010
- [ECOSOC. 1997. Agreed Conclusions.](#)
- Elias M., Mudege N., Lopez, E. Najjar D., Kandiwa V., Luis J., Yila J. Tegbaru A., Ibrahim G., Badstue L., Njuguna-Mungai E., Bentaibi A. 2018. Gendered aspirations and occupations among rural youth, in agriculture and beyond: a cross-regional perspective. *Journal of Gender, Agriculture and Food Security*
- Ellena, R., & Nongkynrih, K. A. 2017. Changing gender roles and relations in food provisioning among matrilineal Khasi and patrilineal Chakhesang Indigenous rural People of North-East India. *Maternal & child nutrition*, 13, e12560.
- Espinoza-Fajardo, J. 2018. Guía de género para políticas públicas más transformadoras. In: *Orientaciones para el análisis y la incidencia política*. OXFAM INTERMON.
- Esquivel V. 2016. Power and the Sustainable Development Goals: a feminist analysis. *Gender & Development*, no. 24, pp. 9-23.
- [European Institute for Gender Equality \(EIGE\). 2019 \(a\). Gender mainstreaming; gender audit.](#)
- European Institute for Gender Equality. 2019 (b). *Intersecting inequalities Gender Equality Index*.
- Farnworth C. & V. Akamandisa. 2011. Report on Gender Action Learning Systems (GALS) Approach to Value Chain Development in Bukonzo Joint Cooperative Microfinance Ltd, Uganda. OxfamNovib and GIZ.
- Farnworth C., C. M. Stirling, A. Chinyophiro, A. Namakhoma, R. Morahan. 2018. Exploring the potential of household methodologies to strengthen gender equality and improve smallholder livelihoods: Research in Malawi in maize-based systems. *Journal of Arid Environments* 149.
- FIMI. 2006. Mairin Lwanka Raya: Indigenous Women Stand against Violence. In: *A Companion Report to the United Nations Secretary General's Study on Violence Against Women*. <https://www.un.org/esa/socdev/unpfii/documents/vaiwreport06.pdf>
- GEDI. 2014. *The Global Gender Entrepreneurship Development Index*.
- Goetz A. and Jenkins R. 2016. Agency and accountability: promoting women's participation in peacebuilding. *Feminist Economics*, no. 22.
- [Hannan Carolyn. 2022. Handbook on gender mainstreaming for gender equality results,](#)
- Harrison L., Nyandiga C. and Hay-Edie T. 2014. Mainstreaming gender, children, youth, and disability into SGP's Community-Based Adaptation Project.
- Health Communication Capacity Collaborative. 2015. *Gender Transformative Approaches An HC3 Research Primer*.
- Hemmings-Gapihan, G. 2008. Climate Change, Subsistence Farming, Food Security, and Poverty: The Consequences of Agricultural Policies on Women and Men Farmers in Burkina Faso and Cote d'Ivoire. *Africa Policy Journal*.
- [Hill Collins P. 2019. Intersectionality as Critical Social Theory. London: Duke university press.](#)
- Hill Collins P. and Bilge S. 2016. *Intersectionality*. Malden: MA Polity Press.
- Hillenbrand, E, N Karim, P Mohanraj, and D Wu. 2015. *Measuring Gender-Transformative Change: A Review of Literature and Promising Practices*. Working

- Paper. https://www.care.org/wp-content/uploads/2020/05/working_paper_aas_gt_change_measurement_fa_lowres.pdf
- Hirshman M. 2003. Women and development: A critique. *Feminism/postmodernism/development*, (Routledge, 2003): 56-59.
- Hoffman O. Yakami S. Dhakal S. 2017. Breaking down barriers: gender and disability in access to agricultural water management in Nepal. *South Asian Water Studies*, vol. 5 no. 4.
- Htun M, Weldon L. 2010. When do governments promote women’s rights? a framework for the comparative analysis of sex equality policy. *Perspectives on Politics*, no. 8, pp. 207–216.
- Huairou Commission. 2016. Final Report, Grassroots Women’s Groups Championing Transformative Rural Development Priorities in the Post-2015 Development Agenda - Forging Blueprints for Holistic, Bottom Up Ownership and Implementation.
- Hubert Agnès and Maria Stratigaki. 2016. Twenty years of EU gender mainstreaming: Rebirth out of the ashes? *Femina Politica—Zeitschrift für feministische Politikwissenschaft* 25, no. 2 (2016): 7-8. International Food Policy Research Institute; International Rescue Committee (IRC); Oxford University;
- [International Indigenous Women’s Forum \(FIMI\). 2019. Voices leading the way: experiences regarding the intersection between environmental justice and economic autonomy of indigenous women.](#)
- Jaquette, J. S. & Summerfield G. 2006. Women and gender equality in theory and in practice: Institutions, resources, and mobilization.
- Jaquette, J. S. 2017. Women/gender and development: the growing gap between theory and practice. *Studies in Comparative International Development* 52, no. 2: 242-260.
- Kabeer N. 2015. Tracking the gender politics of the Millennium Development Goals: struggles for interpretive power in the international development agenda. *Third World Quarterly*, no. 36, pp. 377–395.
- Kabeer, N., 2001. Conflicts over credit: Re-evaluating the empowerment potential of loans to women in rural Bangladesh. *World development*, 29(1), pp.63-84.
- Khullar. A. India’s Gender Budget 2023-2024: Moving Towards Women-led Development. Observer Research Foundation.
- Koczberski G. 1988. Women in development: a critical analysis. *Third World Quarterly* 19, no. 3: 395-410.
- Lamas M. 2013. La antropología feminista y la categoría género. In: *El Género: la construcción de la diferencia sexual*, pp. 97-125.
- Latreille, Martin. 2008, Honor, the gender division of labor, and the status of women in rural Tunisia—A social organizational reading. *International Journal of Middle East Studies* 40, no. 4: 599-621.
- [Lau J., Ruano-Chamorro C., Lawless S., McDougall C. 2021. Gender Transformative Approaches for Advancing Gender Equality in Coral Reef Social-ecological Systems.](#)
- Lee, J. M., Yoo, S. S., & Hong, M. S. 2019. WID, GAD or Somewhere Else? A critical analysis of gender in Korea’s international education and development. *Journal of Contemporary Eastern Asia*, 18(1).
- Little, J. 1987. Gender relations in rural areas: the importance of women's domestic role. *Journal of rural studies* 3, no. 4: 335-342.
- [Loudon, S., C. Goemans and D. Koester. 2021. Gender equality and fragility. OECD Development Co-operation Working Papers, No. 98, OECD Publishing, Paris,](#)
- Matekere T. 2015. The role of men in achieving women’s economic empowerment in Butiama District, Mara Region Tanzania.

- Mayoux, L. 2012. Gender mainstreaming in value chain development: Experience with Gender Action Learning System in Uganda. *Enterprise Development and Microfinance* Vol.23 No.4.
- Mayoux, L. 2013. *Equal and Together: Gender Action Learning for Gender Justice in Development*. Discussion Draft for IFAD.
- Mayoux, L. 2017 (a). *Financial Action Learning System. An integrated methodology for client financial empowerment and responsible financial service provision*. Draft concept note for IFAD.
- Mayoux, L. 2017 (b) *Gender Action Learning for Sustainability at Scale*. Edited Report and Upscaling Plan.
- Mazzucato, M. 2019. *The Value of Everything. Making and Taking in the Global Economy*. Penguin.
- McPhail B.A. 2003. A feminist policy analysis framework: Through a gendered lens. *The Social Policy Journal*, vol. 2(2-3), pp.39-61.
- Mertens D. 2005. Feminism. In: Mathison S, ed. *Encyclopedia of Evaluation*. Thousand Oaks, CA: Sage Publications
- Miller C. & Razavi, S. 1995. *From WID to GAD: Conceptual shifts in the women and development discourse*.
- Miller V, VeneKlasen L, Reilly M and Clark C. 2006. *Making change happen: Power. Concepts for Revisioning Power for Justice, Equality and Peace*. USA.
- Milward, Kirsty, Maitrayee Mukhopadhyay, and Franz F. Wong. 2015. Gender mainstreaming critiques: signposts or dead ends?. *IDS Bulletin* 46, no. 4: 75-81.
- [Molina I. 2019. Desagregación de datos en encuestas de hogares: metodologías de estimación en áreas pequeñas. Series Estudios Estadísticos, no 97. Santiago. CEPAL.](#)
- Monday A. 2018. Practical and Theoretical Limitations of Inclusion of Gender Mainstreaming Strategy. in *Development Activities of Agencies*, *Mediterranean Journal of Social Sciences*, vol 9, no 3.
- Moral-Espín L. and Espinosa Fajardo J. 2021. Putting gender and capabilities into the equation: transformative evaluation for enhancing social justice. *Journal of Poverty and Social Justice*, vol 29, no 3, pp.279–296.
- Moser C. 1989. Gender planning in the Third World: meeting practical and strategic gender needs. *World development* 17, no. 11: 1799-1825.
- Moser C. and Moser A. 2005. Gender Mainstreaming since Beijing: A Review of Success and Limitations in International Institutions. *Gender and Development*. vol. 13 no. 2 pp. 11-22.
- Nikore, M. 2022. *Building India Economy on the Backs of Women Unpaid Work: A Gendered Analysis of Time-Use Data*. Delhi: Observer Research Foundation, Occasional Paper No.372, pg. 4.
- Niti Aayog. 2021. *SDG India Dashboard and Index: Partnership in the Decade of Action*
- Norlander K. 2003. Some reflections on gender relations. In *Gender and Power in the New Europe (The 5th European Feminist Research Conference)*: 20-24.
- Observatorio de Igualdad de Género de América Latina. 2019. *Planes de igualdad de género en América Latina y el Caribe. Mapas de ruta para el desarrollo*. Estudios no. 1. CEPAL. Santiago de Chile.
- Okali C. 2011. *Searching for new pathways towards achieving gender equity: Beyond Boserup and Women's role in economic development*.
- [Ordoñez D. and Aguilera C. 2019. El Poder En la Organización Desde La Perspectiva Psicoanalítica. Revista Universitaria Ruta, no. 21 vol. 2, 13-37.](#)

[Organization of American States \(OAS\). 1994. Inter-American Convention on the Prevention, Punishment and Eradication of Violence against Women \("Convention of Belem do Para"\)](#)

Palacios-López, A. and López, R., 2015. The gender gap in agricultural productivity: the role of market imperfections. *The Journal of Development Studies*, 51(9), pp.1175-1192.

Parpart J. L. 2014. Exploring the transformative potential of gender mainstreaming in international development institutions. *Journal of international Development* 26, no. 3: 382-395.

[Pérez Orozco & Agenjo Calderón. 2020. Economía feminista: viva, abierta y subversiva](#)

[Pérez Orozco, A. 2019. Subversión feminista de la economía. Aportes para un debate sobre el conflicto capital-vida. Traficantes de sueños.](#)

Phillips A. 2004. Defending equality of outcome. *Journal of political philosophy* 12, no. 1 (2004): 1-19.

Quisumbing, A., Gerli, B., Faas, S., Heckert, J., Malapit, H., McCarron, C., Meinzen-Dick, R. and Paz, F., 2023. Assessing multicountry programs through a "Reach, Benefit, Empower, Transform" lens. *Global Food Security*, 37, p.100685.

[Rae B. 2021. Data disaggregation and the global indicator framework. In: ECLAC meeting on Disaggregated data for regional monitoring of the SDGs.](#)

Rangaswami. S. 2023. Analysis of Government Support Policies and Programmes for Women Entrepreneurs in India. GiZ

[Rodó-Zárate M. 2021. Interseccionalidad. Desigualdades, lugares y emociones. Relaciones Internacionales, vol.49, pp. 139–142.](#)

Rodríguez L. 2015. El enfoque de género y desarrollo rural: ¿necesidad o moda?. *Revista mexicana de Ciencias Agrícolas*, vol.1, pp. 401-408.

Roemer J. E. & Trannoy A. 2015. Equality of opportunity. In *Handbook of income distribution* (Elsevier, 2015): 217-300.

Sachs, C. & Caye, V. 1989. Women in agricultural development.

Scott J. 2013. El concepto de género. In *El Género: la construcción cultural de la diferencia sexual*, pp. 21-33.

Sharma, A. N. 2006. Flexibility, employment and labour market reforms in India. *Economic and Political Weekly*, 2078-2085.

Skinner E. 2011. Gender and climate change Overview Report BRIDGE. Institute of Development Studies.

[Stolcke V. 2014. Que tiene que ver el género con el parentesco. In: Cuaderno de pesquisa, no. 44 vol. 151, pp. 176-189.](#)

[Tshatsinde, M. 1993. Rural women in development: Issues and policies. Agenda 9, no. 18: 63-70.](#)
[UN Women. 2000. Women in Development.](#)

United Nations. 1979. Convention on the Elimination of All Forms of Discrimination Against Women, United Nations, Treaty Series, vol. 1249, p. 13.

United Nations. 1997. United Nation Report of the Economic and Social Council, "UN Report". (A/52/3.18).

United Nations. 2015. The 2030 Agenda for Sustainable Development.

United Nations. 2017. UN System-Wide Strategy on Gender Parity.

[United Nations. 2022. The Sustainable Development Goals Report.](#)

[Unmüßig B. 2013. Gender Mainstreaming – Possibilities and Limits of a Radical Social Concept, Heinrich Boll Stiftung.](#)

- Vaca T. & Baron. 2022. Descentrar el producto interno bruto (PIB): bienestar, cuidados y tiempo. Documentos de Proyectos (LC/TS.2022/80). Comisión Económica para América Latina y el Caribe (CEPAL).
- Van de Sand J. 2010. Involving Men in the Fight Against Violence Against Women: Insights in What is Being Done, What Works and Why.
- Van Eerdewijk Anouka and Ireen Dubel. 2012. Substantive gender mainstreaming and the missing middle: a view from Dutch development agencies. *Gender & Development* 20, no. 3 (2012): 491-504.
- Vermeulen, S. et al. 2012. Climate change, agriculture and food security: a global partnership to link research and action for low-income agricultural producers and consumers. *Current Opinion in Environmental Sustainability* 4.1: 128-133.
- Vijayamohanan P. N, Asalatha B. P and Ponnuswamy B. 2009. Women in development- Dissecting the discourse.
- [Viveros. 2016. Intersectionality: A situated approach to dominance.](#)
- Von Borries V. 2012. Reflections on the concept of cross-gender. Outlining a typology for analyzing empirical expressions. *Revista Punto Género*, no 2.
- [Walby S. 2004 \(a\). Mainstreaming de Género: Uniendo la teoría con la práctica, Presentation for the conference Mainstreaming de Género: conceptos y estrategias políticas y técnicas. Andalucía.](#)
- Walby, S. 2004 (b). The European Union and Gender Equality: Emergent Varieties of Gender Regime. *Social Politics: International Studies in Gender, State & Society* 11: 4–29.
- Walby, S. 2005. Gender Mainstreaming: Productive Tensions in Theory and Practice.
- Willis Towers Watson. 2020. Employers prioritize familyfriendly benefits: Findings from the 2020 Emerging Trends in Health Care Survey. US.
- [Wong, Franz, Andrea Vos, Rhiannon Pyburn, and Julie Newton. 2019. Implementing Gender Transformative Approaches in Agriculture.](#)
- [World Economic Forum. 2022. Global Gender Report 2022. Geneva.](#)
- Zalewski. 2010. I Don't Even Know What Gender Is: A Discussion of the Connections Between Gender, Gender Mainstreaming and Feminist Theory. *Review of International Studies*. Doi:10.1017/S0260210509990489
- [Ziegler, S. 2014. Desk study on the intersection of Gender and Disability in international development cooperation.](#)

Consulted websites

- [World Bank. Development Projects : Women in Development \(WID\) Project . Accessed June 21,2022.](#)
- [International Labour Organization, 2019. ILOSTAT Accessed via World Bank DataBank.](#)
- [IFAD website on gender https://www.ifad.org/it/gender, accessed on 14 November 2022.](#)
- [IFAD's Rural Poor Stimulus Facility](#)
- <https://www.cifor.org/wlr>
- <https://gamechangenetwork.org/>
- <https://empoweratscale.org/>
- <http://ilotaqem.groupsites.com>
- <https://www.ifad.org/en/jprwee>
- <https://www.ifad.org/en/gender-transformative-mechanism>
- <https://www.fao.org/joint-programme-gender-transformative-approaches/en>

<https://hdr.undp.org/data-centre/thematic-composite-indices/gender-inequality-index#/indicies/GII>

<https://data.unwomen.org>

<https://www.wfp.org/publications/joint-evaluation-joint-programme-accelerating-progress-towards-economic-empowerment>

<https://www.facebook.com/JPRWEE>

<https://www.youtube.com/channel/UCMuXLipjcfvQW-M9v0HH36A>

<https://asiapacific.unwomen.org/sites/default/files/Field%20Office%20ESEAAsia/Docs/Publications/2017/01/Gender-Dimensions-English-r2s.pdf>

<https://unstats.un.org/sdgs/report/2023/>

<https://www.unwomen.org/sites/default/files/Headquarters/Attachments/Sections/Library/Publications/2019/UN-Women-Policy-brief-11-The-gender-gap-in-agricultural-productivity-in-sub-Saharan-Africa-en.pdf>

<https://data.unicef.org/resources/a-new-era-for-girls-taking-stock-of-25-years-of-progress/>

<https://www.ilo.org/global/research/global-reports/weso/trends-for-women2017/lang--en/index.htm>

<https://data.unwomen.org/features/poverty-deepens-women-and-girls-according-latest-projections>

<https://documents1.worldbank.org/curated/en/190541645548827307/pdf/A-Gender-Employment-Gap-Index-GEGI-A-Simple-Measure-of-the-Economic-Gains-from-Closing-Gender-Employment-Gaps-with-an-Application-to-the-Pacific-Islands.pdf>

<https://gender.cgiar.org/tools-methods-manuals/reach-benefit-empower-transform-rbet-framework>

<https://unfccc.int/topics/gender/workstreams/the-enhanced-lima-work-programme-on-gender>

<https://www.fao.org/3/nn162en/nn162en.pdf>

<https://www.unwomen.org/sites/default/files/Headquarters/Attachments/Sections/CSW/62/CSW-Conclusions-62-EN.PDF>

<https://www.fao.org/in-action/dimitra-clubs/fr/>

<https://www.fao.org/3/cb2401en/CB2401EN.pdf>

<https://unsdg.un.org/sites/default/files/2022-11/Final%20%20UNSDG%20Guidance%20Note%20on%20a%20New%20Generation%20of%20Joint%20Programmes.pdf>

<https://unfccc.int/topics/gender/workstreams/the-enhanced-lima-work-programme-on-gender>

Affirmative Finance Action for Women in Africa, [AFAWA](#).

<https://www.undp.org/sites/g/files/zskgke326/files/2023-10/undp-private-sector-development-and-partnerships-strategy-2023-2025.pdf>

List of interviewees

IFAD Gender (and social inclusion) team:

Gender team at HQ (staff and consultants)

Andrijana Nestorovic - Gender and Social Inclusion Analyst, ECG
 Beatrice Gerli – Senior Technical Specialist (GTM Coord), ECG
 Emily Wylde - Senior Technical Specialist (Social Inclusion - Poverty Targeting), ECG
 Florence Munyiri - Social Inclusion Officer, ECG
 Morane Vehoeven – Consultant, Gender and Social Inclusion, ECG
 Ndaya Beltchika - Lead Technical Specialist, Gender and Social Inclusion, ECG
 Nino Gogsadze - Temporary Professional Officer, SKD
 Petra Jarvinen - Programme Officer (GTM), ECG
 Rachele Arcese – Programme Officer APR, APR
 Sashwati Mishra - Monitoring & Results Specialist (Social Inclusion and Nutrition), ECG
 Shahriar Islam Mir Md - Technical Specialist, Gender and Social Inclusion, ECG
 Silvia Sperandini - Senior Consultant, Gender and Social Inclusion, ECG

Social inclusion/Gender team in the regions

Steven Jonckheere - Senior Evaluation Officer, IOE
 Tshering Choden – Technical Specialist (Soc. Incl. Gender), ECG

Gender team in the country offices or long-term consultants based in the regions/country

Ana Lucía Moreno - Senior Gender Expert, Cerrando Brecha
 Attika Mohammed Elamin Marouf - Community Development and gender Specialist, ESA
 Dhikra Elhidri - Consultant - JP RWEE Coordinator Tunisia, ECG
 Emily Baldassari - Consultant, Social Inclusion, ECG
 Hai Ha Vu Thi - Gender Focal Point Ethiopia, ESA
 Lucie Vergari - Ex Nutrition and SI Technical Specialist Ethiopia, ESA
 Marthe Epassy – Support on gender aspects (for Cameroon case study)
 Victoria Wise - Temporary Professional Officer (Nutrition), ECG

Previous IFAD Gender team

Anita Keller - Gender consultant
 Chiara Romano - Long-Term Consultant, Gender and Targeting
 Clare Bishop-Sambrook - Ex Lead Technical Specialist, Gender and Social Inclusion, PTA
 Elizabeth Ssendiwala - Senior Regional Technical Specialist, Institutions (New Delhi), PMI
 Khadidja Doucoure – ex Regional Gender and Social Inclusion Coordinator, WCA
 Margarita Astralaga – ex Director of Environment and Climate Change (ECC) division
 Maria Hart - Ex Senior Technical Specialist, Gender and Social Inclusion, PTA

IFAD staff in charge of other mainstreaming themes

Alashiya Gordes - Technical Specialist Environment and Climate
 Antonella Cordone - Senior Technical Specialist – Nutrition, ECG
 Iliaria Firmian - Senior Technical Specialist Indigenous Peoples, ECG
 Joyce Njoro - Lead Technical Specialist – Nutrition, ECG
 Karla Sophia Pita Vidal – Consultant Indigenous Peoples, ECG
 Lucie Vergari - Ex Nutrition and SI specialist for Ethiopia, ECC
 Marian Odenigbo - Senior Advisor on nutrition, ESA
 Marie-Aude Even - Senior Biodiversity Specialist, ECG
 Rahul Antao - Professional Officer – YOUTH, ECG
 Suwadu Sakho-Jimbira – Officer Environment and Climate, WCA

Other IFAD divisions

Alaa' Abdel Karim - Regional Financial Management Officer, FMD
 Alejandro Fernández - HR Analyst (e-Learning & Corporate Induction), HRD
 Anja Lesa – Consultant, QAG
 Ann-Charlott Andersson - Senior Finance Specialist (Lead Officer Controllership), FCD
 Athur Mabiso - Senior Economist, RIA
 Audrey Nepveu de Villemarceau - Global Technical specialist – Water & Rural Infrastructure, PMI
 Costanza Di Nucci - Special Adviser to the President, OPV
 David Cuming - Quality Assurance Specialist), QAG
 David Suttie - Communication Officer, Writer, COM
 Dimitra Stamatopoulos - Specialist Policy and Results, OPR
 Edith Girval - Internal Communications, COM
 Estefania Bautista Rivera - Consultant, LAC
 Francisco Rubio - Senior Technical Specialist, ABC Fund, PMI
 Giorgia Salucci - Chief Field Support Unit, FSU
 Harold Liversage - Lead Technical Specialist in Land Tenure, PMI
 Julián Escobar – Consultant, QAG
 Kathy Zissimopoulos - Planning & Resource Management Associate, PMI
 Kim Suyun - Senior HR Specialist (Training, Development & Performance Mngt), HRD
 Lenyara Fundukova - Senior Knowledge Management Specialist, SKD
 Liam Chicca - Head MCO/Country Director, NEN
 Lisa Fantozzi - Consultant and PDT Secretariat, SKD
 Marco Marzano - Lead Global Technical Specialist Institutions, PMI
 Maria Elena Mangiafico - Knowledge Management Specialist, ECG
 Meera Mishra - Country Programme Coordinator, APR
 Pauni Obregon - Legal Officer, LEG

Ricci Simons - Technical Specialist - Environment and Climate Change Consultant, ECG

Richard Aiello - Chief Business Partner Unit, HRD

Sabel Ndure - Partnership Officer, GPR

Seifu Yazhy - Audit Officer, AUO

Silvia Di Pilla - Budget Specialist (Management and Planning), POB

Stefania Lenoci - Head, Private Sector Advisory and Implementation Unit (PAI), PMI

Tarek Ahmed - Lead Portfolio Adviser, WCA

Vibhuti Mendiratta - Senior Economist, RIA

IFAD senior management

Donal Brown - Associate Vice-President, PMD

Guoqi Wu - Associate Vice-President, CSD

Jo Puri - Associate Vice-President, SKD

Juan Carlos Mendoza Casadiegos, Director, ECG

Tom Mwangi Anyonge - Ex Director ad interim and Lead Technical Specialist, youth, ECG

IFAD Country teams

Ahmed Subahi - Sudan Country Programme Officer, ESA

Ann Turinayo - Country Director, WCA

Caroline Celine Onanina - Country Programme Officer, WCA

Claus Reiner - Country Director SSTC & KC, LAC

Emime Ndiokubwayo - Country Director, WCA

Joseph Rostand Olinga Biwole - Ex CPO Cameroon

Juan Diego Ruiz Cumplido - Andean and Southern Cone Hub Head, LAC

Karan Sehgal - Ex Lead Environment & Climate Specialist, APR

Kaushik Barua - Ex Country Director for Cambodia

Marco Camagni - Lead Global Technical Specialist, Rural Institutions, PMI

Meng Sakphouseth - Country Programme Coordinator, APR

Michele Pennella - Specialist Policy and Results, OPR

Paolo Silveri - Country Director, LAC

Philippe Remy - Country Director, NEN

Rachel Senn - Country Director, WCA

Rasha Omar - Country Director, NEN

Roberto Houdry de Soucy - Ex Country Director Argentina

Rodolfo Fernández – Consultant, LAC

Ronald Ajengo - Country Programme Officer, ESA

Seyoum Tesfa - Programme Officer, APR

Zine el Abidine Ghoudi - Procurement Consultant, NEN

Government officials

Ana Pont Verges, Technical Coordinator, PROCANOR-DIPROSE, MagyP, Argentina

Caroline Kamau, Regional Coordinator/Agribusiness Specialist Western/Rift Valley Region (Nakuru) (KCEP CRAL), Kenya

Chan Rith, Provincial Department of Agriculture, Forestry and Fisheries Director (Cambodia)

Deolinda Carrizo, "En Nuestras Manos" Director, Argentina National Institute of Family and indigenous farming, INAFICI, today SAFCI

Elsa Tejada, gender specialist, National Programme of Rural Economic Transformation for living well, El Salvador

Gabriela Alperovich, programme analyst, Ministry of Economy, Argentina

Jorge Arias Almonacid (program director PRODECCA) DIPROSE, MagyP Argentina

Julius Kiva, Regional Agronomist, Eastern Region (Embu) (KCEP CRAL), Kenya

Karina Gutkowski, technician of "En Nuestras Manos", Argentina INAFICI-SAFICI

Lautaro Lissin (program director PROSAF) DIPROSE, MagyP Argentina

Lucila Alvarez (Marcelo Yangosian for the environmental team), DIPROSE, environment, social inclusion and gender, MagyP, Argentina

Markos Mekonen, Ministry of Agriculture, Ethiopia

Martha Sila, Regional Agronomist Western/Rift Valley Region (Nakuru) (KCEP CRAL), Kenya

Naren Ky- deputy director of economic empowerment department, MOWA (Cambodia)

Narjess Hamrouni, Director of the Office for the support to Rural women, Ministry of Agriculture, Water Resources and Fisheries (MARHP), Tunisia

Nhep Sorn, Director of PDAFF (Cambodia)

Sam Sovanna, Deputy Director (Cambodia)

Santiago Blázquez, Responsible PROCANOR, DIPROSE (EAS) - MagyP, Argentina

Sarkmarkna Na, director of women econ empowerment, MOWA (Cambodia)

Sav Kimsoeurn- deputy director Gender Equality and economic development, MOWA (Cambodia)

Sengphal Davine – DDG GE and economic development/Saambat focal point, MOWA (Cambodia)

Stephen Nyakiamo, Regional Monitoring and Evaluation Officer, Western Region (Nakuru) KELCOP, Kenya

Tes Sophal, Director of PDoC Provincial Department of Commerce (Cambodia)

The Chhun Hak– director general in charge of gender equality and econ dev, MOWA (Cambodia)

Valeria Etcheverry, technician of "En Nuestras Manos, INAFICI-SAFICI

Other donors and Joint programmes and grants managers

Ana María Paez-Valencia, Social Scientist, Gender, CGIAR, (global initiative on land)

Andrea Balzano, gender specialist, institutional transformation oversight, UNDP

Anna Eriksen, climate change and resilience building team in WFP Ethiopia CO, Ethiopia

Anne Larson Head of Governance Equity Wellbeing, CIFOR-ICRAF

Aynie Habtamu, Senior Gender Officer, CARE international, Ethiopia
Biruktayet Assefa Betremariam, World Bank Task Team Leader, LLRP, Ethiopia
Brent Libresco, Senior Gender Operations Officer, World Bank Group
Catherine McCarron, global coordinator of JP RWEE
Chansopheak ANN, operations FP for PADEE, now programming (FAO)
Cho Zin Oo Country Programme manager for World Vision
Drew Gardiner, Employment Policy Specialist ILO Geneva
Emmanuel Ateba, UNWomen
Hajnalka Petrics, FAO Previously Global Coordinator of the EU-RBA Joint Programme on Gender Transformative Approaches
Iliana Monterroso, Scientist, Gender, Justice and Tenure, CGIAR, (following the global initiative on land – GTA)
Irenie Chakoma, ILRI research associate
Javier Chamorro, Development Coordination Officer, United Nations Resident Coordinator office, Argentina
Joanne Marie Mc Donough; gender specialist; Diversity, Equity & Inclusion team, World Bank
Kebede ASSEFA, Programme associate – climate change adaptation and resilience team, WFP. Ex PO for JP RWEE for case study.
Kishavar Abdulalishoev, CEO Aga Khan Foundation Tajikistan
Kosal Oum, head of programme FAO
Lauren Philips, Deputy Director, Inclusive Rural Transformation and Gender Equality, FAO (ex IFAD lead advisor, policy and results, OPR),
Maria Teresa Lago, Diversity and inclusion specialist, UNDP
Marlene Elias Alliance Bioversity Gender Lead, Bioversity - CIAT
Ms Azzurra Chiarini, ex coordinator of JPRWEE
Nia Atmadja Stibniati, Scientist, CIFOR;, the Global Initiative for Gender Transformative Approaches - Ethiopia
Pablo Basz, Strategic Partnerships and Financing for Development, United Nations Resident Coordinator office, Argentina
Rahel Tessema, EU Gender Consultant for RUFIP III, Ethiopia
Rebekah Bell, FAO Rep in Cambodia
Rosmary Gonzalez, SI and gender consultant for the JP in Ecuador and Peru
Seung Soy, programme officer, not involved in PADEE
Sikhalazo Dube, ILRI Project Coordinator
Silvia Luchetti, JP RWEE M&E Specialist, World Food Programme
Sun Mao, Ecosun Cambodia University
Susan Kaaria, used to be the team leader on gender in FAO, now Director of the AWARD programme in Nairobi.
Valeria Gorban; HR policy unit, Human Resources Specialist, World Bank
Venus McDonald, Programme Manager, Policy Unit, World Bank

Veruschka Zilveti, Director of Colombian Office of Fundación Capital

Civil society organizations, research institutions and independent experts.

Luz Haro, Executive Secretary, mujeres Rurales LAC

Monica Polidoro, Association of the federal Argentinian Rural Women (AMRAF), Argentina

Pan Sopheap (FNN- FO), Farmer and Nature Net Association, Executive Director
Cambodia

Rieky Stuart, gender expert, evaluator of the IOE CLE on gender

Santiago Sarandon, Universidad Nacional de La Plata- Laboratorio de Investigación y Reflexión de Agroecología - LIRA

Silvia Papuccio de Vidal, focal point Agroecology and Gender

Sok Sotha (CFAP – FO), Federation Association of Agricultural producers, Founder and Managing Director, Cambodia

Viviana Blanco, Universidad Nacional de La Plata (Gender and Indigenous Peoples)

Viviana Sacco, PROCASUR coordinator

Yun Mane, CIPO Indigenous leader, Cambodia

Participants to engagement workshop in March (only those not interviewed individually)

Ahmed Subahi, Country Programme Officer, NEN

Alessandra Garbero, Lead Regional Economist, NEN

Amine Zarroug, Regional Specialist, NEN

Audrey Tchoundi, Temporary Professional Officer, PMI

Claire Orengo, consultant

Claudia Wong, Country Programme Officer, LAC

Elisa Cifello, Junior Consultant - Mainstreaming themes validation, OPR (Safeguards, Mainstreaming, Compliance and Climate Tracking)

Fanny Grandval, Senior Regional Technical Specialist, Rural Institutions WCA, PMI

Gianluca Capaldo, Senior Portfolio Advisor, NEN

Giulia Gentile, Office of Strategic Budgeting, OSB

Gozde Becerik, Consultant Gender, ECG

Iliaria Gasparre, Regional Analyst, APR

Shantou Abe, Junior Professional Officer, APR

Additional interviews for the country case studies:

Ethiopia interviews

Ahmed Ali Ahmed, Safeguards Officer, LLRP

Damena Lemma, Gender and Nutrition Advisor, LLRP

Gelebo Orkaido, Livelihood Officer, LLRP, SNNP

Gezehagn Gelebo, Gender & Nutrition Specialist, PASIDP-II, SNNP

Misgana Lemma, External Fund and Credit Management Directorate of the Development Bank of Ethiopia, RUFIP

Mohamed Yusuf, Livelihood Officer, LLRP

Shibabaw Tarekegn, Livelihoods Officer, LLRP, Benishangul Gumuz

Kenya Interviews:

Augustino Mugendi Mwaniki, Desk officer Mbooni Sub County

Brown Ojuku, Soi Sambu Field Extension Officer

Caroline Mbaja, Rangwe Sub County Fisheries Officer

Collins Otieno, Programme Fisheries Technician

Collins Wanyonyi - Equity Bank, Bungoma Branch, KCEP-CRAL

Cosmas Muniyeke, KCEP-CRAL Senior Programme Coordinator

Cyril Wasike, Agriculture Officer I – Ward Agricultural Officer in-charge of Kwanza

David Harrison Aura, Samia Sub County Coordinator

David Mukabane, County Director of Livestock

Dorcas Wasai, Tongaren Ward Agriculture Officer.

Elisham Andalia, Tongaren Sub County Agribusiness Development Officer

Elizabeth Mwanza Makau, Mbooni Ward Agricultural Officer – GALS gender focal point

Eric Matiti, Cherangany Sub-County Desk Officer and Agribusiness specialist

Fredrick Makini, Country Director of Social Development Services

Fredrick Wotia, County Director of Agriculture (CDA)

Gabriel Radoli Shiundu, County Project Coordinator

Geoffrey Masengeli, KCEP-CRAL Trans Nzoia Desk Officer

Godfrey Musumba, Elugulu Ward Livestock officer.

Grace Njagi, ABDP Aquaculture Specialist

Hezron Oyanda, Proprietor of Fisheries Enterprises, Homa Bay County (ABDP)

Jonathan Muniyao, KCEP-CRAL County Coordinator Makueni

Josphine Simiyu, Tongaren Sub County Agriculture Officer

Kenneth Luga, County Programme Coordinator

Kevin Ouko, County Programme Fisheries Officer

Kevin Wamira, Programme Fisheries Officer

Kona Akuku, County M&E Programme Officer

Loice Akinyi, Focal Point person for social inclusion

Martha Ndungu, Kwanza Sub County Agricultural Officer

Mary Nekesa Barasa, Agro-dealer – Bunyala Stores - Soi Sambu Ward, Homa Bay County

Mary Oremo Olale, Homa Bay Town Sub County Fisheries Officer

MaryStella Wambwoba, Desk Officer/Gender focal Person

Michael Nyabala, Teacher Roba Primary School Fisheries Project, Homa Bay County

Michael Omondi, ABDP County Programme Coordinator (GALS Master Trainer).

Michael Waweru, ABDP Senior Monitoring & Evaluation & Knowledge Management & Specialist

Moses Kembe, KELCOP National Project Coordinator

Moses Obongo, Level 2/Farmer Champion – GALS TOT Kisumu County
 Noreen Adongo, Nabuku Ward Livestock Extension Officer
 Onesmus Mutua, Cooperative Bank Makueni Branch, KCEP-CRAL
 Pamela Kimkung, KCEP-CRAL Gender, Training and Community Mobilization Officer
 Patrick Osoro Okongo, County Chief Officer for Agriculture, Irrigation, Livestock & Fisheries
 Peter Ndambiri, GALS TOT - Sustainable management services SMS, KCEP-CRAL
 Peter Ogulo, County Director of Social Services
 Richard Adhiambo, County Chief Officer, Agriculture, Livestock, Fisheries and Agribusiness
 Rodah Juma Karani, Tongaren Ward Agricultural Officer – GALS TOT
 Rosemary Kyalo, Ward Agriculture Officer, Muvau/Kikuumini Ward
 Samson Machera, County Programme Coordinator
 Sarah Amoit, County Social Services officer
 Siplicious Mukok, County Executive Committee Member (CECM) Agriculture, Livestock, Fisheries, Climate Change, Blue Economy
 Stephen Murithi, National Drought Management Authority, KCEP-CRAL
 Susan Ngera, County Extension Training Officer
 Timothy Kioko Musyoki, Ward Agriculture Officer, Tulimani
 Titus Kiprono, Sub County Agricultural Officer – Cherangany Sub County
 Wicliff Onyimbo, Butula Sub County Livestock Officer
 Winfred Olubai, KELCOP Social Inclusion Specialist
 Zachari Winam, Programme Fisheries Officer/Gender Focal Person

Sudan Interviews:

Abdelrahman Mohamed Ali Sheikh, Sudan, Senior M&E Expert /SNRLP CPCU
 Aida Osman, SNRLP Youth development and gender specialists
 Alfafa Gisiema Babay, Livelihood expert
 Asawir Zaki, Sudan Microfinance Development Facility for (SMDF) for SNRLP
 Attika Ameen – Gender Officer also in charge of nutrition and capacity building of farmers’ organizations in IAMDP
 Azahir Ahmed Elsaid, Community development officer, North Kordofan
 Eltahir Artori, MF SNRLP Sudan Microfinance Development Facility
 Hind Fagiri, Micro Enterprise and Social Development Specialist for North Kordofan State and Progressive gender Officer
 Ibrahim Rahmatallah, Natural Resources Management Officer, LMRP
 Manal Abdalla Mohamed Ali, Community development officer, Abu Hugar, Sennar State
 Mekki Abdalla Adam, IAMDP PCU
 Mohamed Gama’a Adam, Sudan Forestry Officer, South Kordofan State
 Mohammed El Hassan Ali, Natural Resource Management Expert/ SNRLP CPCU, previously worked on BIRD in Butana

Nadir Yousif Hamdan, LMRD, Project Director of Livestock Marketing and Resilience Programme

Sundus Abdalla Ali Ismaeil, Community Development Officer, Goz locality (Adibaibat), South Kordofan State

Tahani Mohamed Hassan, Locality Extension Team Leader, North Kordofan State

Yassin Doleeb, project director of SNRLP

Tunisia interviews

Ahmed Mejri, M&E officer, Tunisia PROFITS-Siliana

Asma Khehidri, GEWE and targeting officer, PROFITS-Siliana

Fatma Ben Mahmoud, graduation approach, Union Tunisienne de Solidarité Sociale

Mohsen Mastour, Coordinator IESS-Kairouan

Najibi Edriss, Gender and Social Inclusion responsible, IESS-Kairouan

Ouji Chokri, Coordinator PROFITS-Siliana

Salma Jalouali, Coordinator PRODEFIL

Shanti Kumar, Technical Officer for the Ultra-Poor Graduation Initiative, BRAC

Argentina interviews

Ana Sonsino, National institute of Agropecuary technology (INTA) on the capacity building strategy of the Programme, PROSAF

Diego Ramilo, Director of the research centre for Family Agriculture (AF): INTA project on climate change and agroecology, PROSAF

Mariana Stegagnini, Centre for Federal development studies foundation (CEDEF) on rural connectivity, gender and access to technologies. PROSAF

Marisa Fogante, founder of Suelo Común, member of the national network of municipalities and communities that Support Agroecology (RENAMA).

Natalia Oliari, responsible of the elaboration of gender indicators at the Ministry of Economy and at the Ministry of Women's Affairs

Cambodia interviews

Kim Channary – gender focal point/chief production div bureau of private sector development-MOC. AIMS

Ouk Samnang, Director ASPIRE, SRET, and PADEE PIU

Pen Vuth, coordinator ASPIRE/PADEE,

Phum Tol - gender/targeting consultant MRD, SAMBAAT

Seng Tuy - deputy director of SRET- MAFF

Sieng Komira – project manager, AIMS

Sok Narom – MEF-PIU national coordinator, SAMBAAT

Sorn Vichet - project manager,

Touch Siphath- project manager, SAMBAAT

Ung Dara Roth Moni – team leader, AIMS

Vutha Koung- digital technology coordinator MEF PIU, SAMBAAT

War Samnang, SRET Technical and Business Development Advisor

Cameroon interviews

Alex Sonkwe, responsible for pedagogy, teaching, targeting Cameroon PEA-J

Christian Kouebou, agricultural technical specialist, nutrition component, PADFA II

Divine Tombuh, cordonator PPEA

Gilbert Momo, M&E responsible, PEA-J

Hyacinthe FOUNSIE, rural financing responsible PEA-J

Isabelle Makota, Director of Women's Economic Promotion, MINPROFF, focal point PADFA

Josiane NDOMO, gender, communication and KM specialist, IFAD Cameroon.

Martine ONGOLA, Director of Women's Social Promotion, MINPROFF, focal point, PEA-J

Myriam Gaelle Kakambi Fopa, Structuring and marketing specialist, PADFA II

Olivier NDAM POUFOUN, Business Development Specialist, PEA-J

Rodrigue Ankan, M&E responsible, PADFA II

Solange Bangweni, Head of Cooperation Unitk, MINPROFF, focal point, PADFA II

Zakari CHINDAP, M&E responsible, PDEA

Additional interviews were conducted by IOE teams in charge of the evaluations in **El Salvador, Mauritania, Ethiopia, India and Türkiye.**

Senior independent advisers' report

Joint statement of the independent advisers, Dr Dee JUPP, Independent International Development Consultant and Advisor and Dr Donna Mertens, Professor Emeritus from Gallaudet University, Washington DC, on the final report of the Thematic Evaluation of IFAD's support on GEWE.

This thematic evaluation focusing on gender must be praised for its comprehensiveness and clarity given its vast scope. It is timely and underscores the importance and need to address gender equality and women's empowerment (GEWE) in agriculture on a global scale because not doing so will impede progress in attaining Sustainable Development Goal 5. In its 2019 Gender Action Plan, IFAD has astutely recognized that GEWE requires that root causes of inequalities between women and men be identified and challenged, including the distribution of resources and allocation of roles and responsibilities, unequal power dynamics, and discriminatory social structures and gender norms and roles. Through its investments in pilots and innovation in GEWE, it has the potential to serve as a leader in this field through its influence on partner governments and demonstrating how positive GEWE change can happen.

Quality of the thematic evaluation

Both authors of this note were involved as external independent advisors from the outset and were asked to provide advice on the draft approach paper prepared in 2022 and comments on the draft final report before publication.

The thematic evaluation data collection strategies were quite comprehensive, including a laudable attempt to develop a theory of change. The comprehensive mix of methods and efforts to ensure triangulation provides a high level of confidence in the findings. The evaluation report concludes with recommendations for action that are well supported by the evaluation data.

Challenges and limitations for the evaluation

The evaluators faced considerable challenges in reconciling the internal documentation on gender during the time period the evaluation covered. Guidance notes reflected an evolution in thinking, changed priorities, and sometimes were inconsistent and confusing. Terms and the meaning attached to terms were open to different interpretations. The evaluators should be commended on the work they have done to make sense of the different periods and key moments and on their ability to relate their findings to the prevailing contexts.

The evaluators appropriately recognized limitations of the thematic evaluation that have implications for evaluations funded by IFAD. For example, the quality of gender information was variable and some information about key factors such as outreach indicators and GEWE budget allocations was missing. The current metrics valorize outreach (participation output) and the existence of gender action plans and gender staff (process input). This misses the quality of the experiences of men and women, the actual benefits, contributions to women's empowerment, and results for intersectional groups that require attention for equity to advance. For example, data are needed to indicate if the women who are participating represent those who are truly poor and to challenge assumptions. With most projects achieving high gender ratings, there is a need to re-visit the basis of these ratings.

Opportunities for improved design

The need for improvement in project design is endorsed, especially incorporation of the principle *'that gender transformative change must come from the communities and societies where this change occurs and cannot be imposed from outside'* (RBA Joint Programme) which in turn necessitates the determination of needs and important contextual constraints and resources during design. The evaluation highlights weaknesses in gender analysis at design (especially since 2018 re-organization) and the

lack of opportunities to listen to beneficiaries which affects the quality and relevance of GEWE elements in design. The addition of the fourth pathway in the Theory of Change which requires the *'use of spaces for rural women and men to reflect on how to challenge and change social norms that lead to gender inequality'* is key to tackle the norms and root causes which hinder progress and has important design implications for programmes and for evaluations. The evaluation rightly recommends shifting this towards framing gender in terms of opportunity and women as change agents.

There is a need to ensure design is informed by historical and contemporary contextual data collected about cultural variables and intervention strategies are developed to mitigate, for example, men's resistance to women's inclusion in financial decisions or to shift men's oppressive cultural perspectives, among others. The household methodologies represent a positive move towards a participatory approach that can contribute to GEWE. However, additional data must be collected on the cost, time, use, and number of people engaged in the household methodologies.

Opportunities for improved evaluation

The evaluators identified the need for IFAD to develop an institutional agreement on the measurement of women's empowerment and IFAD is undertaking an iterative approach to developing such tools. Progress in using IFAD's empowerment indicator needs to be continuously monitored. IFAD does not currently report at the corporate level on contributions towards its three gender-related strategic objectives. Endorsing the principle that change must come from the communities themselves and not imposed from outside, it is important that the development of metrics should involve rural farmers and should resonate with them and be valued by them. Participation in the evaluation could also contribute to addressing root causes by including more contextual analysis and use of mixed methods that collect data on the quality of the experiences of men and women, the actual benefits as perceived by the communities, contributions to women's empowerment, and results for intersectional groups that require attention for equity to advance.

Evaluation needs to better consider how gender intersects with other social identities and axes of power. When projects report on vulnerable groups such as young people, Indigenous People, or people with disabilities, they do not disaggregate the data by gender. The intersection of gender and climate change is not fully considered. In addition, gender is treated as a binary concept (men/women) throughout IFAD's policies and practices, as well as in this evaluation. This misses opportunities to address the needs of gender minorities who identify as LGBTQ.

Opportunities for Policy Engagement

The evaluation revealed an opportunity for IFAD to examine formal inclusion of gender transformative approaches and gender transformative programming in their policy and action plans. Additionally, IFAD as a hybrid financing and implementing agency has a unique opportunity to work in partnership with governments to influence GEWE policy and practice. However, this potential can only be achieved with much improved evidence gathering and analysis of what works in bringing about change in different contexts. Additional resources and capacity building is vital for IFAD to fulfil this potential.

Another opportunity for IFAD is to examine its corporate documents to increase its emphasis on the improvement of legal frameworks needed to address root causes of inequality. Future policy needs to be forward-looking and recognize the need to address root causes of inequality in practical, context-specific ways. The evaluation also revealed that most member states endorse addressing root causes of gender inequality but are reticent to adopt gender transformative approaches, possibly because of a lack of understanding of the concept. This offers IFAD an opportunity to explore the basis of the reticence and initiate interventions to address this challenge.

Opportunities in knowledge management

It is noted that a number of knowledge dissemination approaches have been discontinued (Gender breakfasts, regional briefs on key gender and social inclusion issues). Staff and partners identified the need for practical guidance which is actionable. The evaluation recommends the development of a comprehensive gender toolkit which is easily accessible. Cost data needs to be collected to inform the design of measuring empowerment in gender transformative approaches.

The Thematic Evaluation Report is an extremely rich resource (including important detail in footnotes and annexes) but represents a reading challenge for over-stretched staff and consultants. Additional resources may be needed to disseminate the results further.

Opportunities to enhance organizational capacity

IFAD has made a commitment to work towards GEWE and gender transformative approaches. To live up to this commitment, additional human resources are needed to support the accompanying increase in workload. The finding that gender focal points spend less than five per cent of their time on gender activities is particularly concerning and this needs attention. It is concerning that less than half of design missions include gender experts and that they are not integral and valued in all missions. Given the expectation to move the goal posts from measuring participation (outputs) to measuring outcomes (changes in behaviour), the need for dedicated gender expertise and advice who receive appropriate training becomes even more important. The evaluation makes a compelling case for the need for enhancing gender expertise within IFAD, especially those having contemporary understanding of context and familiarity with current research. The perceived lack of support from senior management, the nature of positions into which women are hired, and issues of work-life balance all would benefit from attention.

Conclusions

The domain encompassing GEWE is both context- specific and under flux. Evidence is emerging about the increasing marginalization of boys (education and employability, for example), progress on gender equity is plateauing or even regressing in some contexts, and new challenges present themselves with the recognition of the disproportionate effects of climate change and fragile environments on women. IFAD must continually examine these emerging trends and challenges and ensure that policy, guidance, and evaluation accommodates these. The global reach of IFAD and its need to produce organization-wide evidence of change should not cloud the recognition that change happens asymmetrically (and not necessarily linearly) in different contexts. Small but significant changes in challenging situations need to be valued.